

PLAN

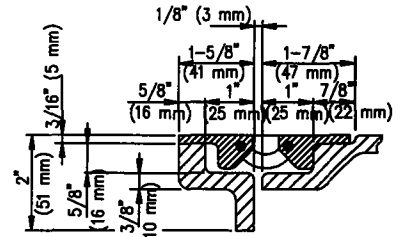

SECTION B-B

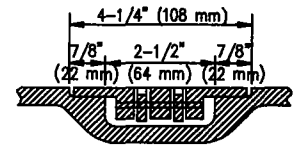

SECTION C-C

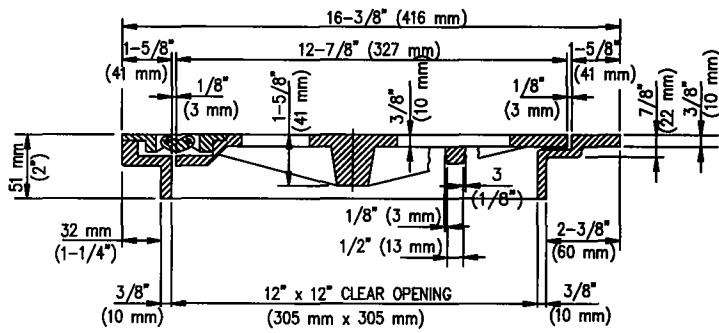

SECTION A-A

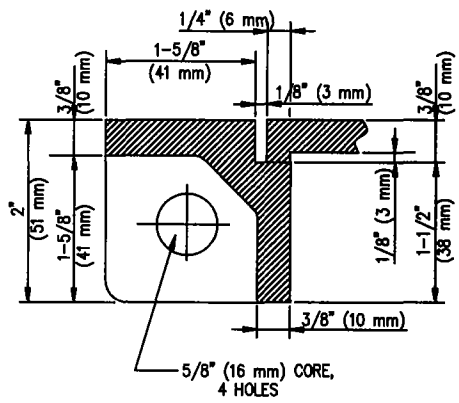

SECTION D-D

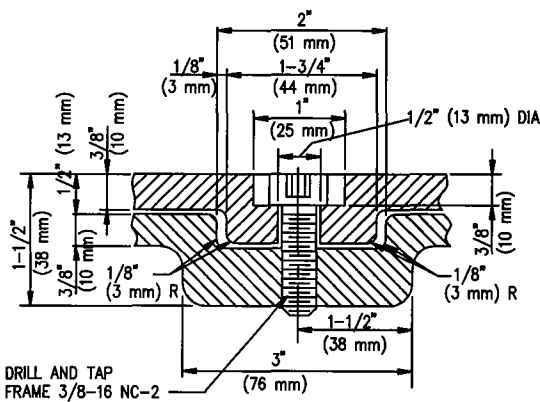

SECTION E-E

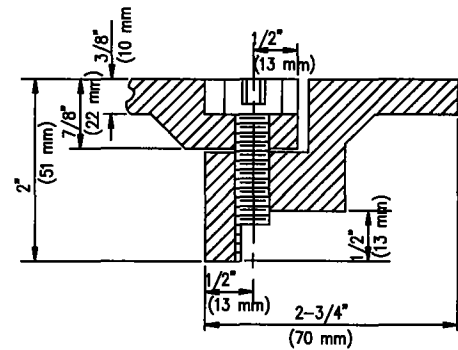

SECTION F-F

STANDARD PLANS FOR PUBLIC WORKS CONSTRUCTION

PROMULGATED BY THE
PUBLIC WORKS STANDARDS INC.
GREENBOOK COMMITTEE
1993
REV. 1996, 2009

RECTANGULAR FRAME AND COVER

USE WITH STANDARD SPECIFICATIONS FOR PUBLIC WORKS CONSTRUCTION

STANDARD PLAN

152-2

SHEET 1 OF 2