

REV. 12-74: DELETE ϕ NOTE (Support Bolt on C.B. 2)
 REV. 12-78 REV. C.B. 1, 2 & 3

REARRANGED DIMENSIONS A, B, AND D.

DRAWN BY L.L.L. 5-67 CHECKED BY G.J.B. 7-67
 REV. 4-69: ADDED ϕ NOTE, AND NOTE NO. 2;
 REV. 5-72: RELOCATE C.B. LOCATION TIE

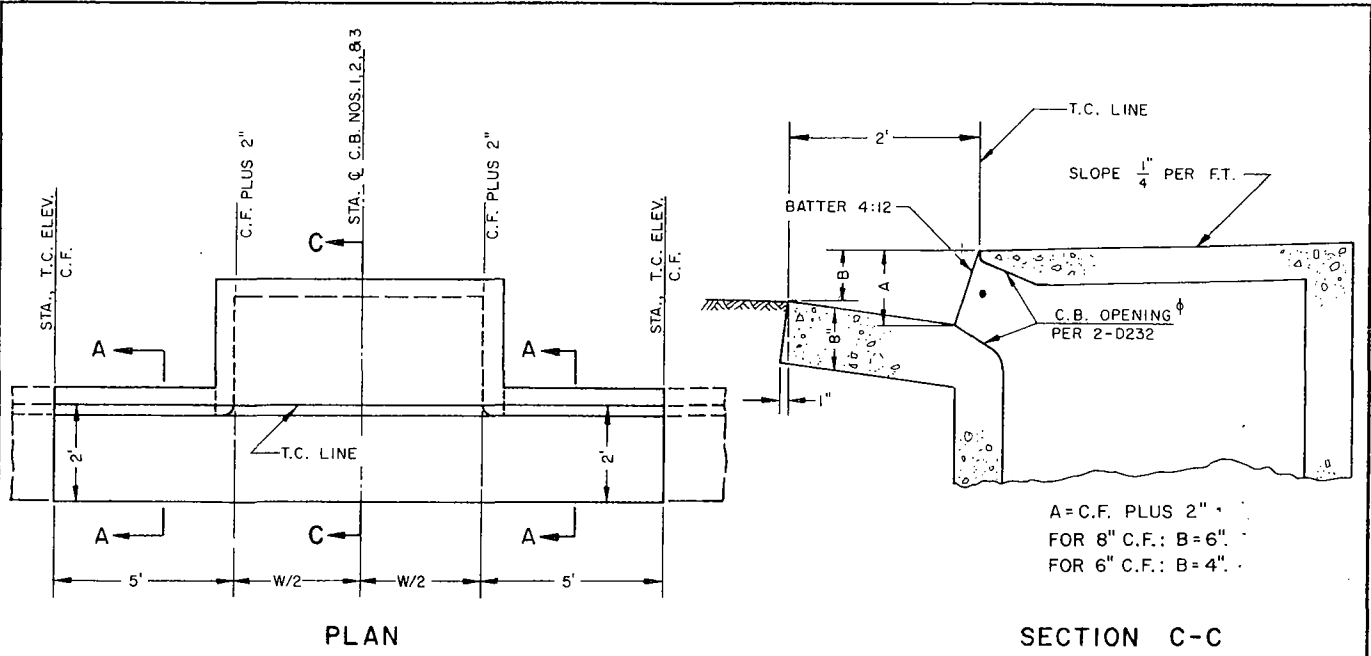

PLAN

SECTION C-C

L.A.C.F.C.D. CATCH BASIN NOS 1, 2, & 3

A = C.F. PLUS 2"
 FOR 8" C.F.: B = 6"
 FOR 6" C.F.: B = 4"

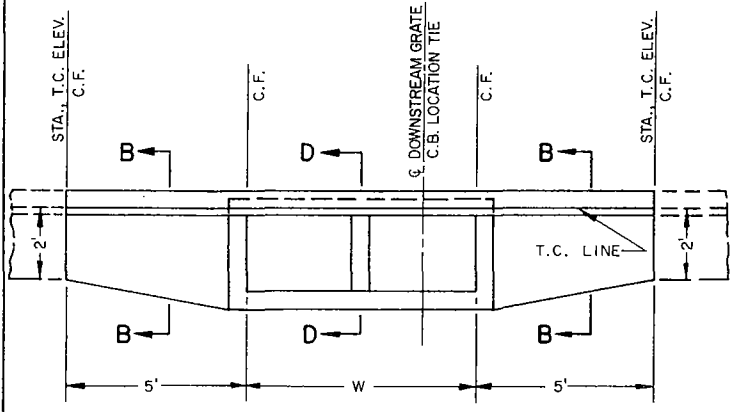

PLAN

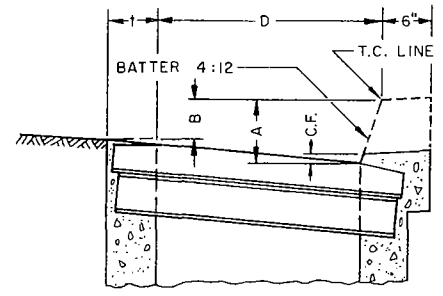

SECTION D-D

WHEN A = 8": THEN B = 5' 2 1/4" ; D = 2' - 4 3/16"
 A = 6": THEN B = 3' 3 3/4" ; D = 2' - 3 1/2"

L.A.C.F.C.D. CATCH BASIN NO. 4

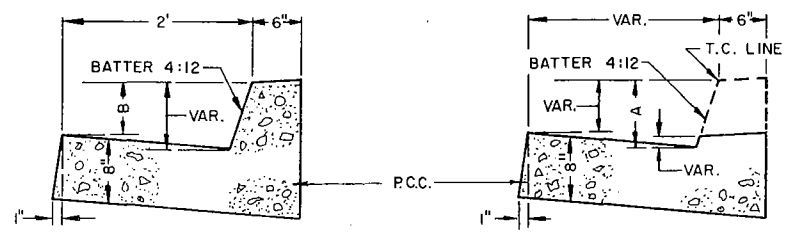

NOTES: SECTION A-A

SECTION B-B

1. STATIONS, ELEVATIONS, CURB FACE, "W", AND CATCH BASIN LOCATION ARE AS SHOWN ON IMPROVEMENT PLAN.
2. ALL L.A.C.F.C.D. CATCH BASINS, EXCEPT ALLEY TYPES, SHALL BE CONSTRUCTED WITH MODIFICATIONS AS SHOWN HEREON UNLESS OTHERWISE INDICATED. BATTER OF ADJOINING CURB SHALL GOVERN OVER THIS STANDARD.
3. COST OF MODIFICATIONS AS SHOWN HEREON SHALL BE INCLUDED IN THE CONTRACT PRICE PAID FOR THE RESPECTIVE CATCH BASINS.

LOS ANGELES COUNTY ROAD DEPARTMENT

CURB & GUTTER TRANSITIONS & MODIFICATIONS
 FOR USE WITH L.A. CO. F.C.D. CATCH BASINS

STANDARD PLAN

66-03

APPROVED

J. J. Mosher 1 Dec 67
 ROAD COMMISSIONER DATE

PAGE 1 OF 2

REVISED 12-78

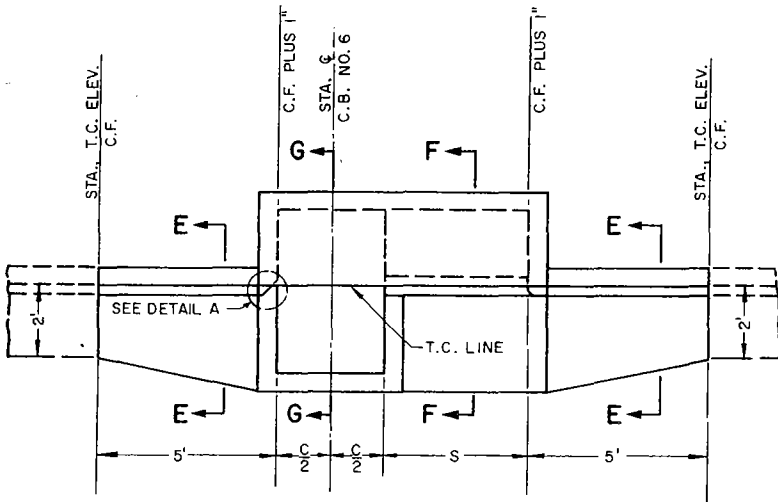

PLAN

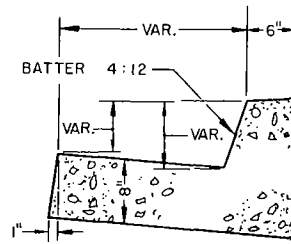

SECTION E-E

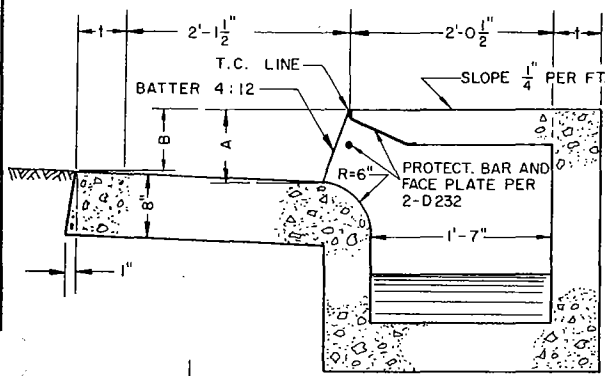

SECTION F-F A = C.F. PLUS 1"
 FOR 8" C.F.: B = 5 3/4"
 FOR 6" C.F.: B = 3 3/4"

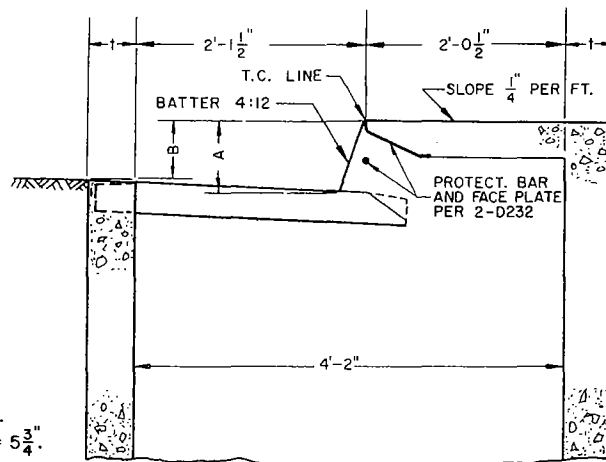

SECTION G-G

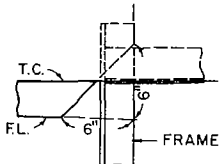

DETAIL A

L.A.C.F.C.D. CATCH BASIN NO. 6

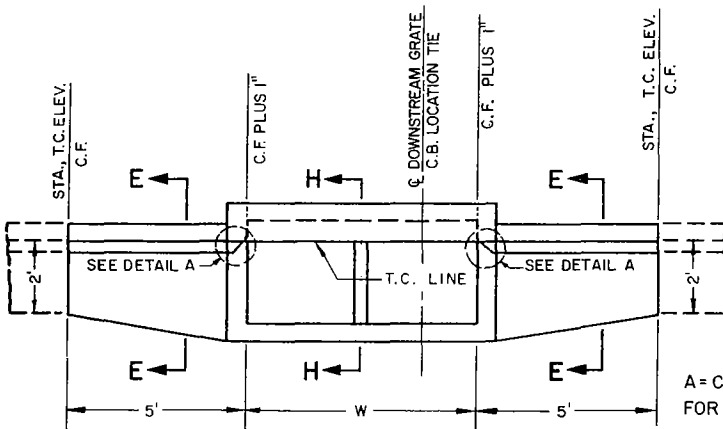

PLAN

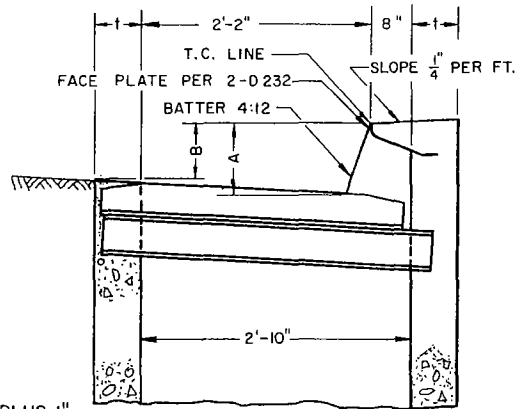

SECTION H-H

A = C.F. PLUS 1"
 FOR 8" C.F.: B = 5 3/4"
 FOR 6" C.F.: B = 3 3/4"

L.A.C.F.C.D. CATCH BASIN NO. 7

DRAWN BY: L.L.L. 5-67 CHECKED BY: G.J.B. 7-67
 REV. 4-69 : REPLACED W/2, IN PLAN FOR C.B. NO. 6, WITH C/2 AND S; REARRANGED DIMENSIONS A, AND B;
 REV. 6-70 : ADDED DETAIL A
 REV. 5-72 : RELOCATE C.B. LOCATION TIE, DELETE MODIFY FRAME NOTE.
 REV. 7-73 : SECT. H-H, DIMENSIONS
 CHANGED 2'-1" TO 2'-0 1/2" IN SECT. F-F, AND G-G.

LOS ANGELES COUNTY ROAD DEPARTMENT

**CURB & GUTTER TRANSITIONS & MODIFICATIONS
 FOR USE WITH L.A.CO.F.C.D. CATCH BASINS**

STANDARD PLAN

66-03

PAGE 2 OF 2

REVISED 7-73