

TOP OF COVER

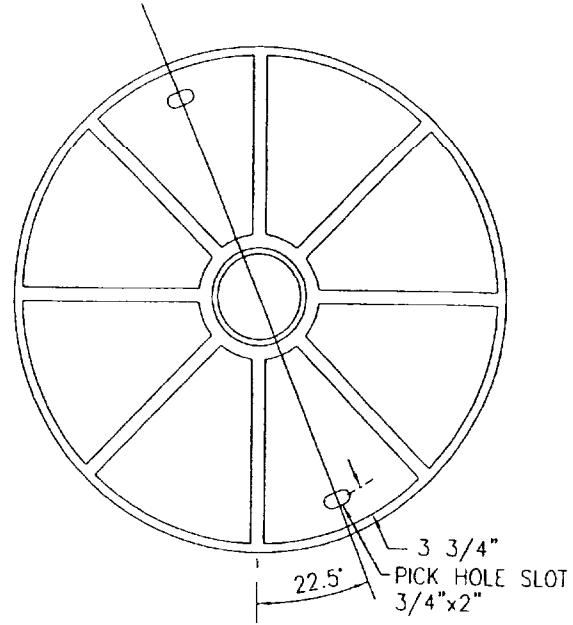

BOTTOM OF COVER

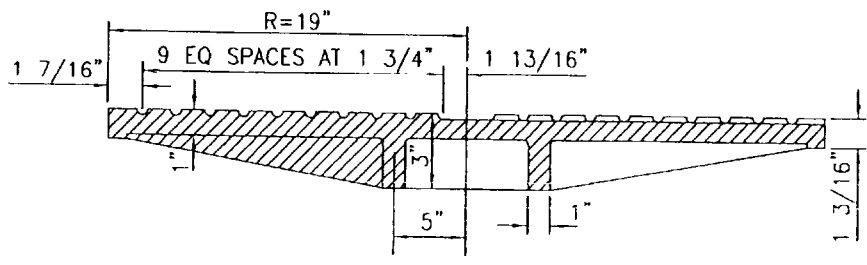

SECTION A-A

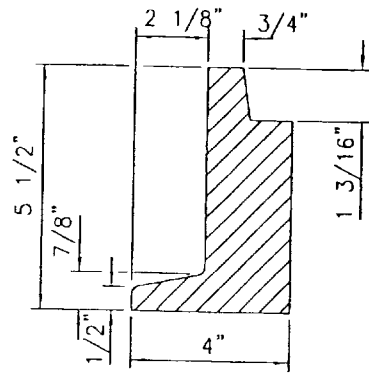

FRAME DETAIL

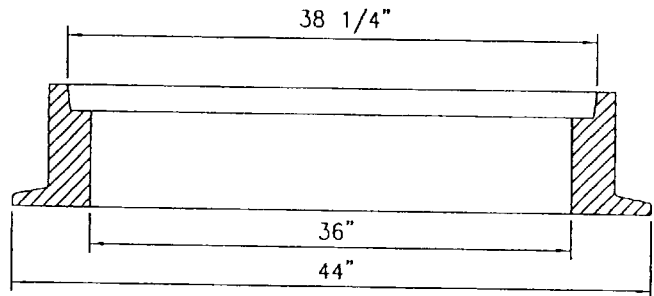

SECTION THRU FRAME

NOT TO SCALE

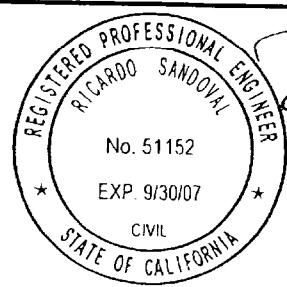

APPROVED BY: *Ricardo Sandoval* 10-18-06  
 CITY ENGINEER  
**RICARDO SANDOVAL**  
 REVIEWED BY: *Jb*  
 DATE OF LAST REVISION: \_\_\_\_\_

CITY OF FONTANA	
36" MANHOLE FRAME AND COVER	
STD. PLAN NO. 3023	SHT 1 OF 2

07/10/06

NOTES

1. THE CAST IRON USED SHALL CONFORM TO ASTM A-48 CLASS 35B.
2. COVERS SHALL BE CAST WITH THE LETTER "D" FOR STORM DRAINS AND "S" FOR SEWERS, AND THE AGENCY'S IDENTIFICATION IN ACCORDANCE WITH INSTRUCTIONS FURNISHED BY THE AGENCY. THE LETTER "D" OR "S" SHALL BE APPROXIMATELY 2-1/2" HIGH WITH 1/2" LINE WIDTH, AND PLACED IN THE CENTER OF THE COVER. ALL LETTERS SHALL BE FLUSH WITH THE FINISHED SURFACE OF THE COVER.
3. FOUNDRY IDENTIFYING MARK, HEAT AND DATE SHALL BE CAST ON THE BOTTOM OF THE COVER AND ON THE INSIDE OF THE FRAME.
4. IMPORTED COVERS AND FRAMES SHALL HAVE THE COUNTRY OF ORIGIN MARKING IN COMPLIANCE WITH FEDERAL REGULATIONS.
5. WEIGHT OF FRAME SHALL BE 335 LBS. WEIGHT OF COVER SHALL BE 340 LBS. ACTUAL WEIGHTS SHALL BE WITHIN A RANGE OF 95% TO 110%.
6. THE MANHOLE FRAME AND COVER SHALL BE INSPECTED BY THE ENGINEER PRIOR TO SHIPMENT TO THE JOB SITE. ACCEPTANCE WILL BE INDICATED BY THE AGENCY'S MARK.
7. THE PROOF-LOAD FOR TEST METHOD B OF THE STANDARD SPECIFICATIONS IS 41,300 LBS.
8. COVERS FOR MANHOLES LOCATED IN EASEMENTS, ALLEYS, PARKWAYS AND ALL PLACES OTHER THAN PAVED STREETS SHALL BE PROVIDED WITH SOCKET-SET SCREW LOCKING DEVICES. DRILL AND TAP TWO HOLES TO A DEPTH OF ONE INCH AT 90 DEGREES TO PICK HOLE AND INSTALL 3/4"x3/4" STAINLESS STEEL SOCKET-SET SCREWS WITH 3/8" RECESSED HEX HEAD. ALL THREADS SHALL BE N.C.
9. DIMENSIONS SHOWN ON THIS PLAN ARE NOT EXACTLY EQUAL VALUES.

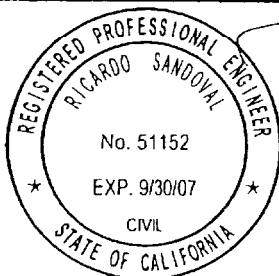

APPROVED BY: *Ricardo Sandoval*  
 CITY ENGINEER DATE 10.18.06  
 REVIEWED BY: *JS*  
 DATE OF LAST REVISION: \_\_\_\_\_

CITY OF FONTANA	
36" MANHOLE FRAME AND COVER	
STD. PLAN NO. 3023	SHT 2 OF 2

07/10/06