

RAISING RINGS TO BE MADE OF STEEL, ASTM DESIGNATION AT MERCHANT QUALITY

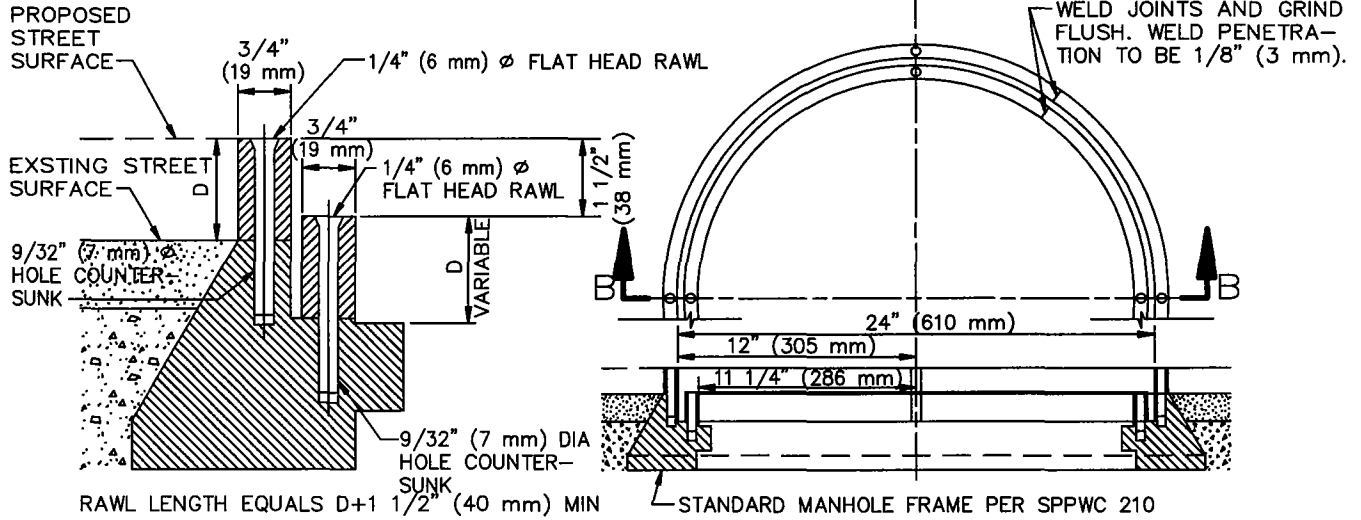

SECTION B-B

STEEL RAISING RINGS

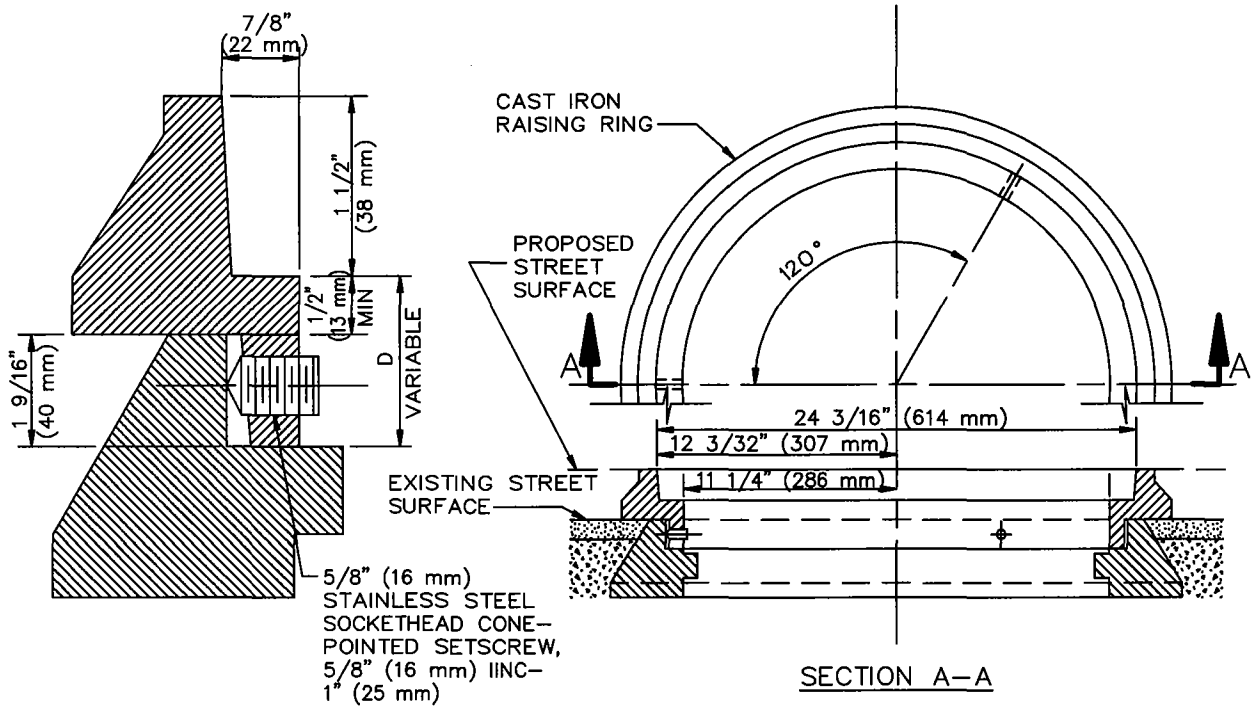

SECTION A-A

CAST IRON RAISING RINGS

STANDARD PLANS FOR PUBLIC WORKS CONSTRUCTION

PROMULGATED BY THE
PUBLIC WORKS STANDARDS INC.
GREENBOOK COMMITTEE
1984
REV. 1996, 2009

MANHOLE RAISING RINGS

STANDARD PLAN

206-2

USE WITH STANDARD SPECIFICATIONS FOR PUBLIC WORKS CONSTRUCTION

SHEET 1 OF 2