

NOTES:

1. SEATS OF FRAME AND COVER SHALL BE MACHINED TO PREVENT NOISE
2. TOTAL WEIGHT OF FRAME AND COVER APPROX. 380 LBS.
3. MINIMUM CLEAR OPENING 24" DIA. FOR 48" MANHOLES ALL OTHER DIMENSIONS ARE NOMINAL. ALHAMBRA-A-1254-LETTERED-"COB-SD."

MATERIAL: CAST IRON (ASPHALT COATED) 1" 3/4"

4. MINIMUM CLEAR OPENING 30" DIA. FOR ALL 60" & LARGER MANHOLES ALHAMBRA A-1252-LETTERED-"COB-SD."

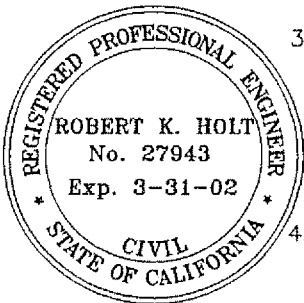
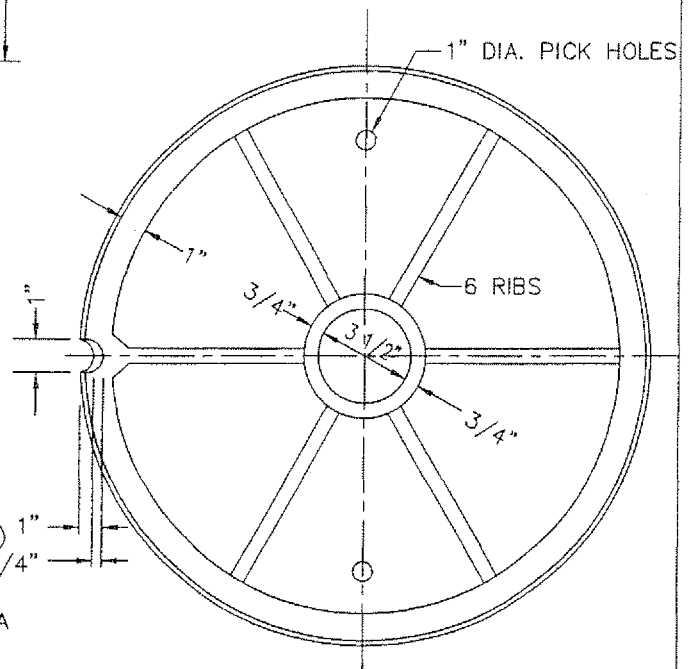

APPROVED: PUBLIC WORKS DIRECTOR

James W. Rodkey Jr. DATE *9/7/00*
 JAMES W. RODKEY, JR.

Robert K. Holt DATE *8/31/00*
 ROBERT K. HOLT, P.E.

CITY OF
BLYTHE

MANHOLE FRAME &
 COVER - ROADWAY

STANDARD DRAWING NO. SD-519

REVISION

BY DATE