

SIMILAR TO EXCEPT AS UNDERLINED:
 ORANGE CO NO. _____ THUS _____
 STATE OF CALIF _____ THUS _____

DATE: 5-1-67 SUPERSEDES: _____ DATED _____
 REV: _____

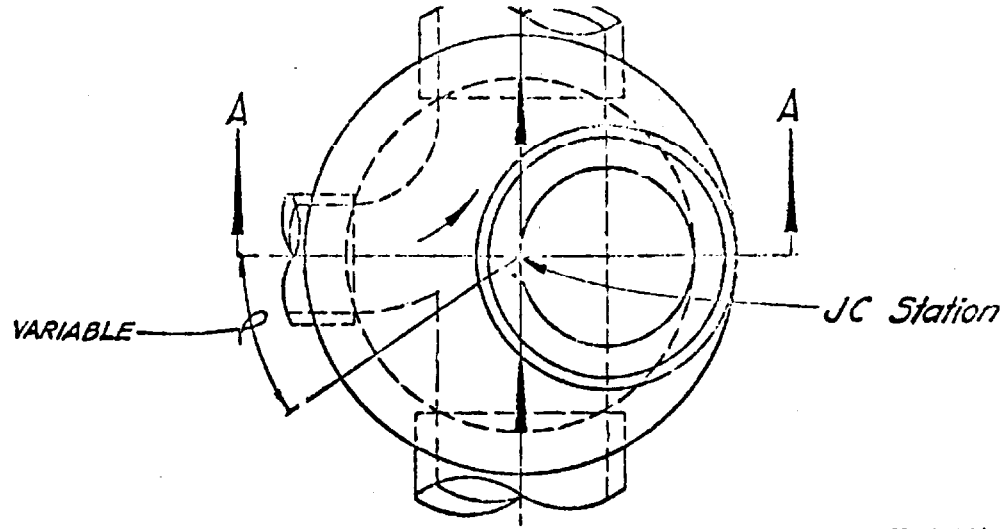

PLAN

CAST IRON FRAME AND COVER,
 STD 512, 408.
 GRADE RINGS - SEE NOTE 14.

NOTE:
 REINFORCED MANHOLES
 CONFORMING TO SECTION 70-
 1.02.H OF THE CALIF STD SPECS
 WILL BE PERMITTED

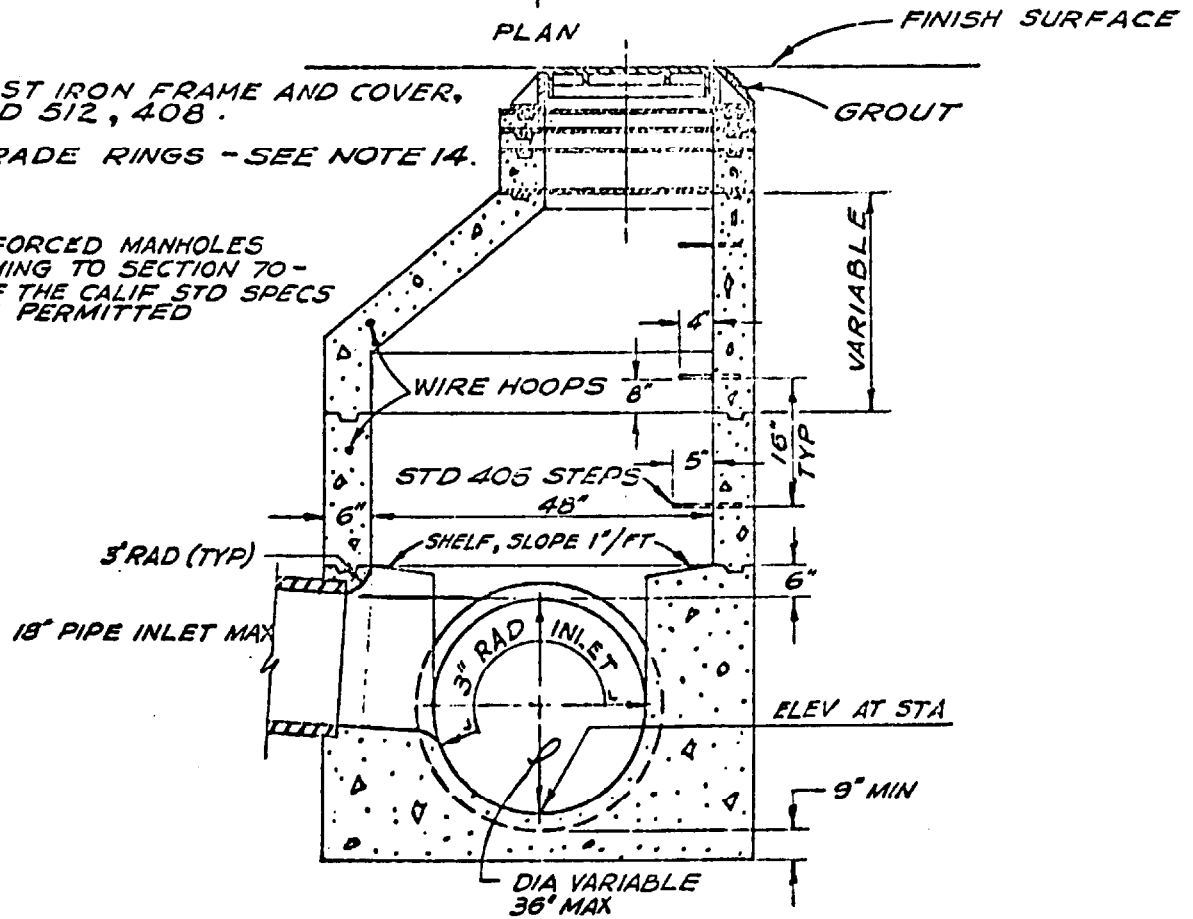

SECTION A-A

CITY OF BREA

CITY ENGINEER

STANDARD
 SHEET 1 OF 2

JUNCTION CHAMBER - 36 IN. PIPE MAX

516

UNLESS OTHERWISE SPECIFIED ON PLANS AND SPECIFICATIONS:

1. All prolonged centerlines of drains, entering a junction, shall intersect at the center of the chamber.
2. Stations of junctions, shown on the plans, apply at center of chamber. Elevations are shown at center and refer to the flow line.
3. Outlet pipe shall be trimmed to the final shape and length before concrete is placed.
4. Place monolithic base, over compacted earth; concrete shall be Class A, per the California Division of Highways - Standard Specifications.
5. The interior of base shall be hard, smooth, troweled. The circumference to receive a precast manhole section shall not be troweled, but shall be grooved to receive joining grout.
6. All mortar shall consist of one part Portland cement and two parts sand.
7. All precast sections shall be either centrifugally spun or vibrated in metal forms.
8. Place the bottom precast section on a 1/2" thick bed of mortar placed on the manhole base. Mortar between sections shall be a minimum 1/2" thick.
9. Set top of manhole in plane of parkway; one-quarter inch per foot slope toward top of curb.
10. See STD 512 for parkway frame and cover.
11. See STD 402 for manhole installation outside the street or traveled way.
12. See STD 405 for Flat Top manhole.
13. If laterals enter on both sides, manhole shall be located on side of smaller lateral.
14. There shall be a maximum height of 9 inches for 24-inch ID sections for manholes less than 12 feet in depth. There shall be a maximum height of 21 inches for 24-inch sections for manholes that exceed 12 feet in depth.

PRECAST APPROVED SOURCE

NAME	ADDRESS
Associated Concrete Products, Inc.	4025 W. Talbert Ave., Santa Ana
American Pipe & Construction Co.	4635 Firestone Blvd., South Gate

CITY OF BREA

CITY ENGINEER

STANDARD
SHEET 2 OF 2

JUNCTION CHAMBER - 36 IN. PIPE MAX

516