

## STEEL ANGLE AND SUPPORT BOLT DETAIL

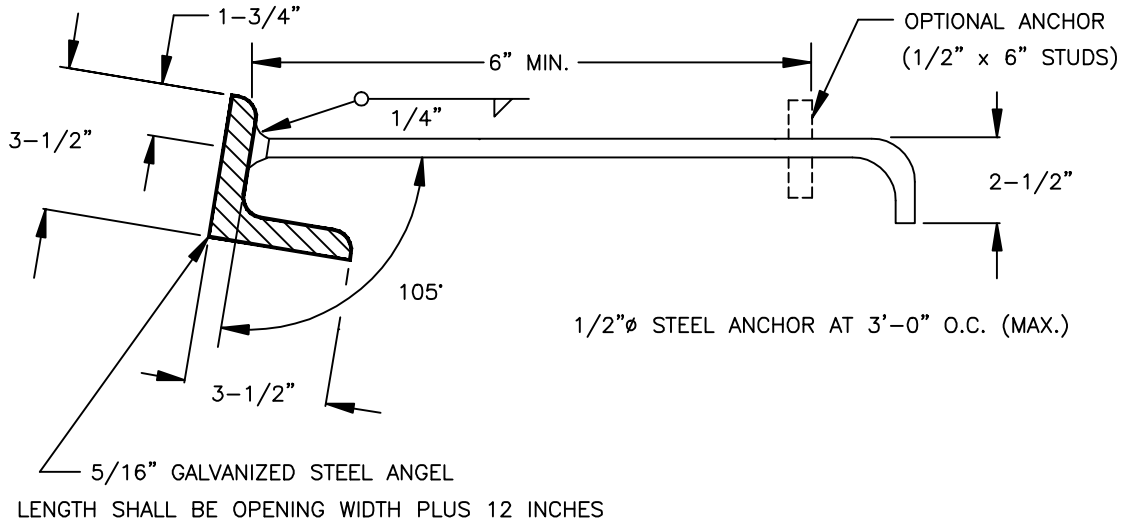

## STEEL ANGLE ANCHOR

1. A PLAIN ROUND GALVANIZED STEEL PROTECTION BART 3/4" IN DIAMETER SHALL BE INSTALLED AND EMBEDDED 6" EACH END.
2. ALL EXPOSED METAL PARTS SHALL BE GALVANIZED. (EXCEPT FRAME AND COVER)
3. SUPPORT BOLTS SHALL BE UNIFORMLY SPACED BUT NOT TO EXCEED SEVEN (7) FEET ON CENTER.
4. STEEL ANGLE SHALL BE BENT TO MATCH ALIGNMENT.

CITY OF CHINO HILLS

CHRIS VOGT  
CITY ENGINEER

CATCH BASIN OPENING

205A