

NOTES

1. MANHOLE FRAME AND COVER SHALL BE CAST IRON OR STEEL WITH A MINIMUM WEIGHT OF 315 POUNDS.
2. ALL CASTING RADIII SHALL BE 1/8" UNLESS OTHERWISE NOTED.
3. CUT-OUT SHALL BE PLACED IN RIM OF COVER OPPOSITE PICK HOLE.
4. FRAME AND COVER SEAT SHALL BE MACHINED.
5. THIS MANHOLE FRAME AND COVER ARE FOR USE IN TRAFFIC AREAS.
6. MANHOLE FRAME AND COVERS MAY BE ALHAMBRA FOUNDRY COMPANY A-1254 OR AN APPROVED EQUAL.
7. THE MANHOLE FRAME AND COVERS SHALL BE GALVANIZED AFTER FABRICATION, IF MANUFACTURED FROM STEEL.
8. THE MANHOLE FRAME AND COVERS SHALL BE MATCHED IN PAIRS PRIOR TO DELIVERY TO THE WORK AREAS AND THEY SHALL FIT WITHOUT ROCKING.

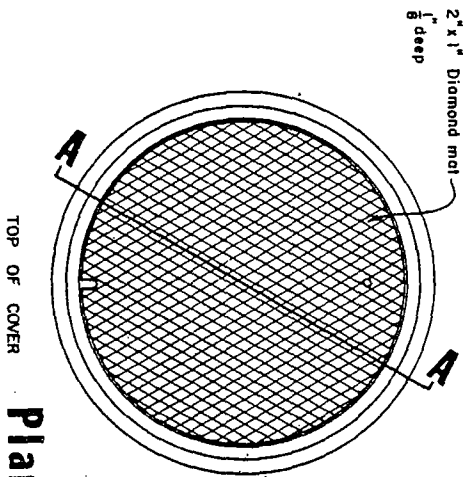

Plan View

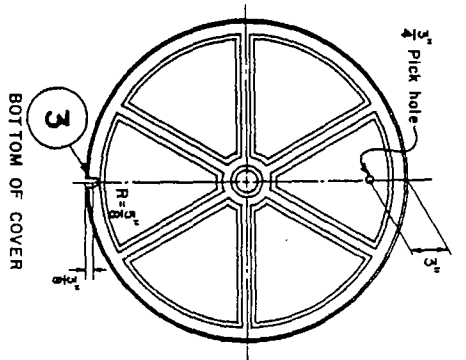

Section A-A

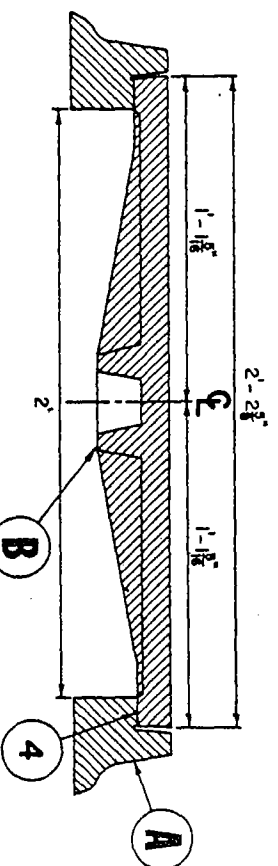

Section A-A

COUNTY OF SANTA BARBARA, CA. -- DEPARTMENT OF PUBLIC WORKS -- ROADS DIV.

Approved by

2-105

MANHOLE FRAME AND COVER No. 2

Charles W. Brown
DIRECTOR OF PUBLIC WORKS

4/1/87
DATE