

PLAN

Alhambra Foundry A-1531 galv. or equal.
Shipping weight (frame and cover) = 130 lbs
(see Std Plan 407)

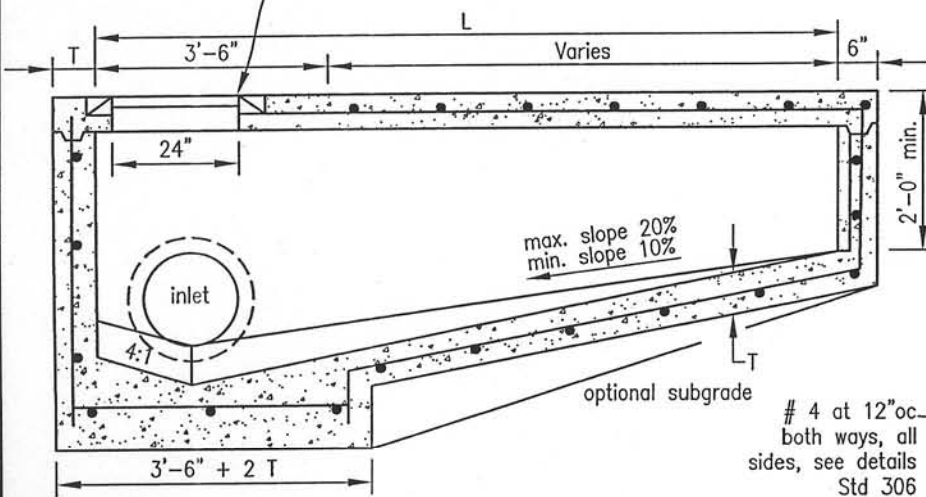

SECTION A-A

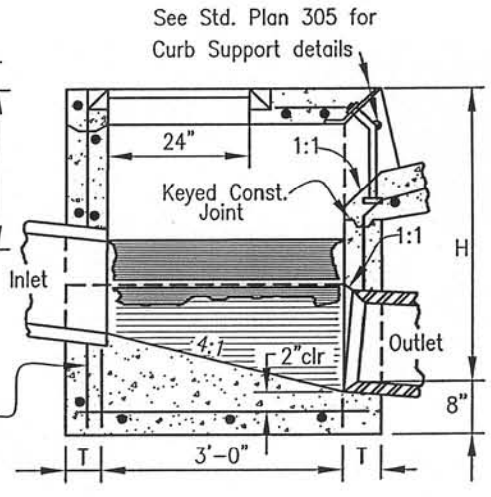

SECTION B-B

H	T	L	MIN H
8'-0"	6"	7'	3.54'
or Less		10'	3.84'
8'-1" to	8"	14'	4.24'
20'-0"		21'	4.94'

NOTES:

1. Standard opening lengths "L", are 7', 10', 14', and 21'. Other lengths may be used.
2. See Std. Plan 329 for pipe connection details.
3. Curb opening shall conform to curb alignment.
4. See Std. Plans 305, 306 for details and notes.
5. See Std. Plan 307 or 308 for Local Depression details.



3-25-04
DATE APPROVED

[Signature]
PUBLIC WORKS DIRECTOR/C.E.
[Signature]
ASSISTANT CITY ENGINEER

CITY OF ORANGE PUBLIC WORKS DEPARTMENT

INLET TYPE II
(O.L.)

STANDARD
PLAN No.
302