

PLAN

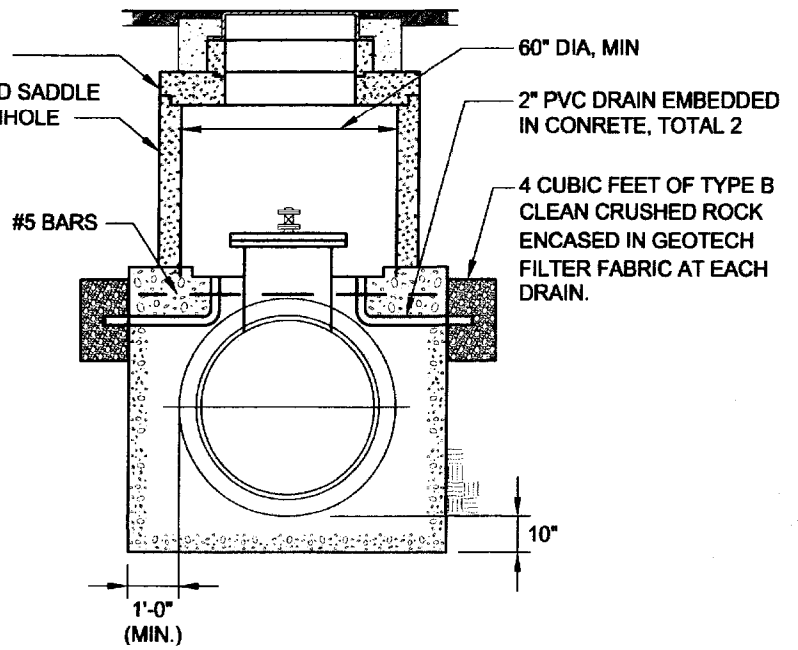

SECTION A-A

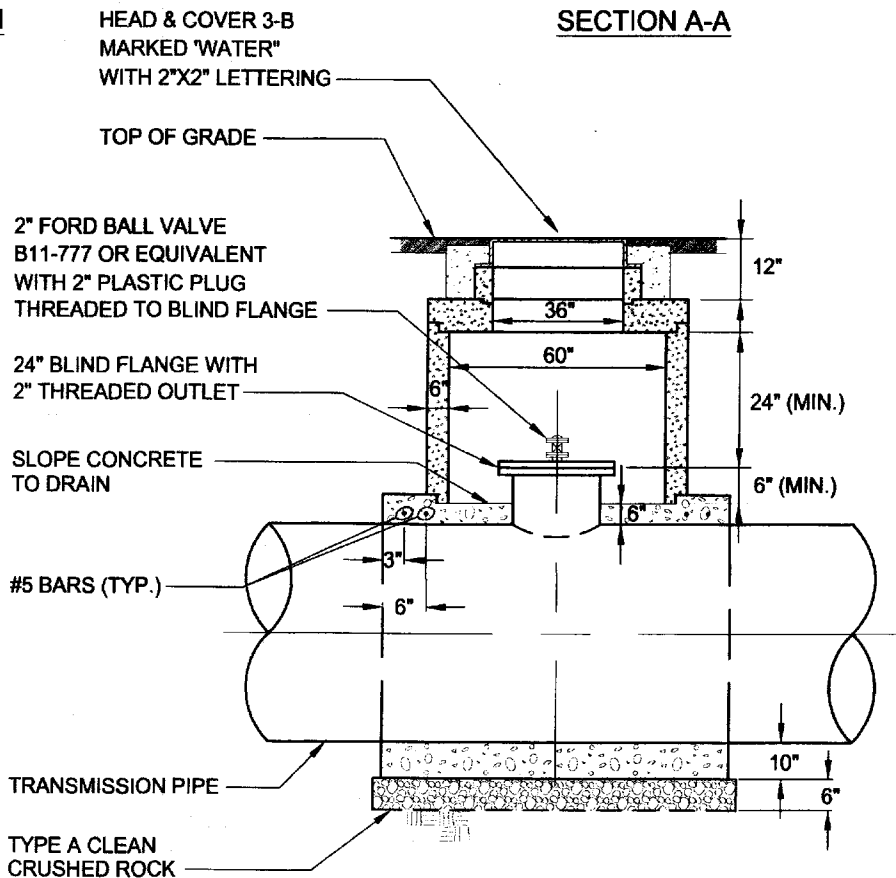

SECTION B-B

NOTE:

- 1. MANHOLE SHALL CONFORM TO SECTION 25

REV.	DATE	DESCRIPTION

R:\Utilities\City_Std_Details\Water_Utilities\W-702