

NOTES:

1. STEPS SHALL BE STEEL CONFORMING TO ASTM A307 AND SHALL BE GALVANIZED AFTER FABRICATION. UNLESS OTHERWISE NOTED, STEPS MAY ALSO BE POLYPROPYLENE STEPS, STEEL REINFORCED, CONFORMING TO SPPWC 636.
2. IF STAINLESS STEEL STEPS ARE REQUIRED, THE MATERIAL SHALL CONFORM TO ASTM A276, 300 SERIES.
3. STEP ENDS MAY BE TYPE 1, 2 OR 3, AS SHOWN.
4. BOTTOM STEP SHALL BE A MAXIMUM OF 2' (600 mm) ABOVE FLOOR OR SHELF.
5. STEPS WITH TYPE 1 OR 2 ENDS MAY BE CAST IN PLACE, OR PLACED IN THE CENTER OF 1-1/2" (40 mm) MIN DIA DRILLED OR FORMED HOLES AND SET WITH HIGH STRENGTH NON-SHRINK GROUT, 6000 PSI (40 MPa) MIN. STEPS WITH TYPE 3 ENDS SHALL BE CAST-IN-PLACE.

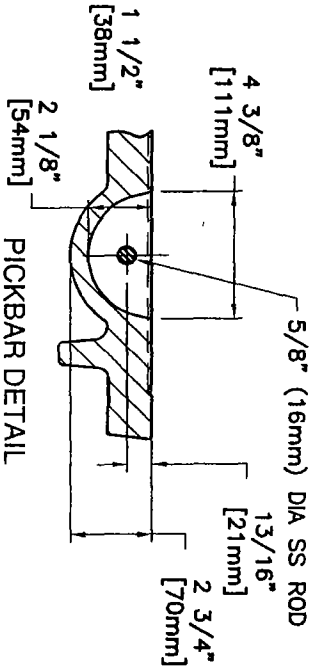
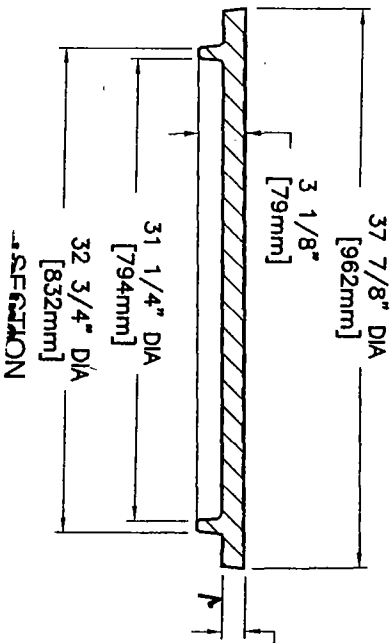
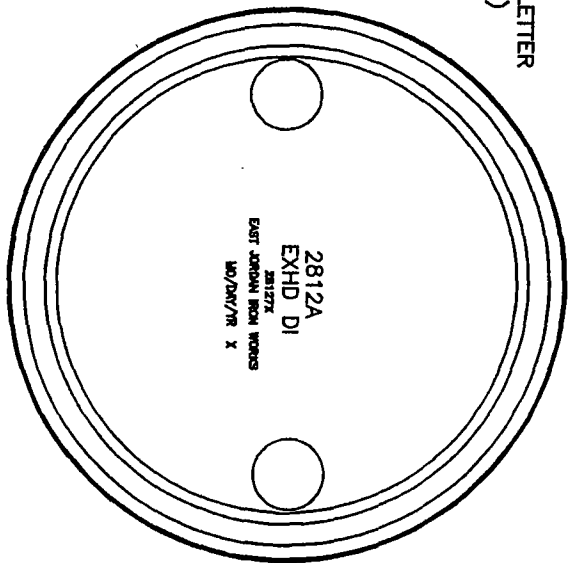
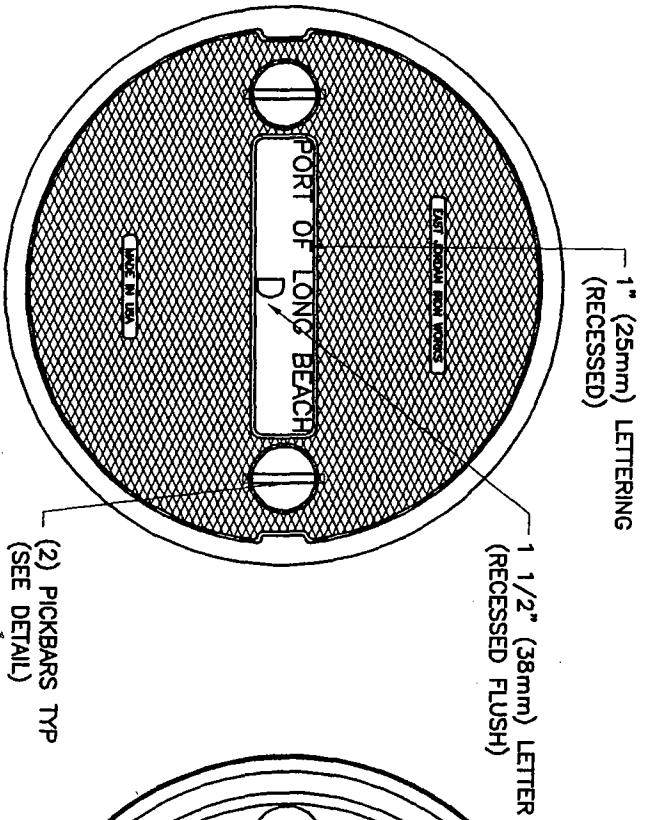

BOTTOM VIEW

LBIW, Inc.
Long Beach Iron Works, Inc.
 2020 West 14th Street
 Long Beach CA 90813-1042
 562 432-5451

CONFIDENTIAL: This drawing is the property of East Jordan Iron Works, Inc. and embodies confidential information, trade secret information, and/or know how that is the property of East Jordan Iron Works, Inc. © Copyright 2006 East Jordan Iron Works, Inc.

EJ IW EAST JORDAN
 IRON WORKS EST. 1883

800-626-4653
 www.ejiw.com
 MADE IN USA

PRODUCT NUMBER
00281232

CATALOG NUMBER
2812A EXHD DI

MANHOLE COVER

LOAD RATING
EXTRA HEAVY DUTY
 (PROOF LOAD TESTED
 TO 200,000 LBS.)

COATING
DIPPED

ESTIMATED WEIGHT
 COVER: 441 LBS 200kg

MATERIAL SPECIFICATION
 COVER - DUCTILE IRON
 ASTM A536

OPEN AREA
 N/A

✓ DESIGNATES MACHINED SURFACE

DRAWN	DATE
DEW	09/22/06
LAST REVISED	DATE
DEW	09/22/06

REFERENCE INFORMATION

00281223