

NOTES:

1. Flo-Gard(tm) Filter body is prefabricated from polypropelene woven monofilament geotextile.
2. All metal components shall be stainless steel (Type 304).
3. Refer to application chart for catch basin and filter sizing.
4. Filter medium shall be Fossil Rock(tm) installed and maintained in accordance with manufacturer's recommendations.
5. Refer to manufacturer's recommendations for maintenance program.

6. Flo-Gard(tm) inserts may be installed (without adsorbent pouches) during course of construction as a sedimentation control device. After construction, remove sediment and install adsorbent pouches.

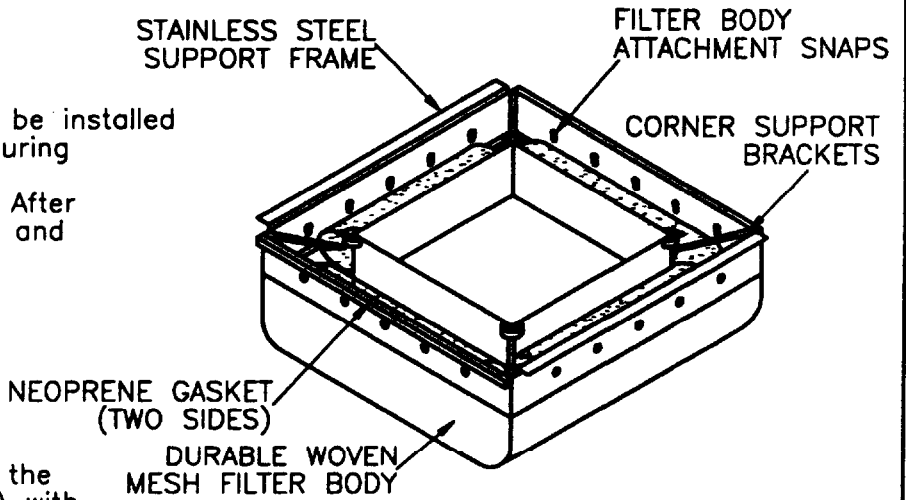

Note: Contractor shall supply the manufacturer of Flo-Gard(tm) with City Standard Details of the Drop Inlet to insure proper sizing.

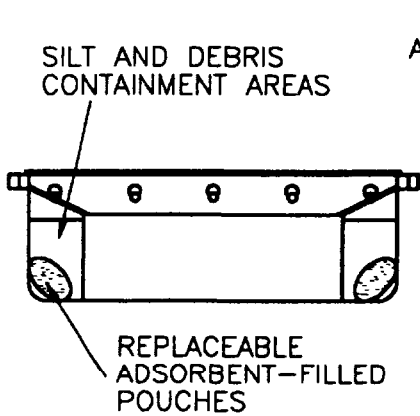

SECTION VIEW

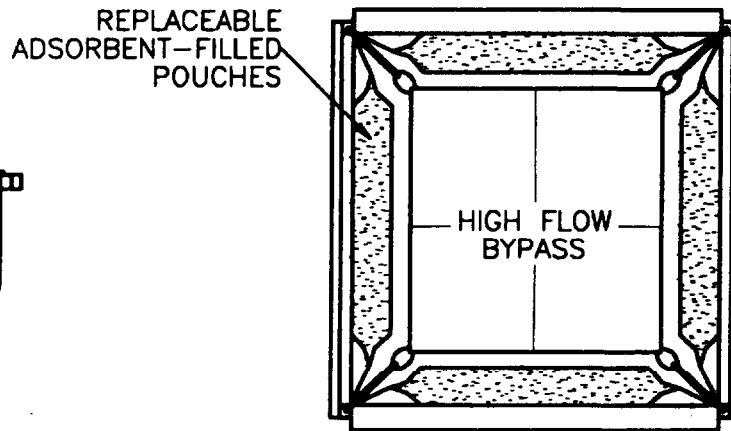

TOP VIEW

SCALE: NONE

**FOSSIL FILTER(tm)
FLO-GARD(tm)
CATCH BASIN INSERT**

KriStar Enterprises, Inc., Santa Rosa, CA (800) 579-8819
PATENT PENDING

Approved:

[Signature] 29 JUNE 07
Director of Public Works/
Designee

[Signature] 29 June 07
R. James Garing, RCE 26993
City Engineer



City of Grover Beach

Catch Basin Insert

D.4b