

REV.	APPR. BY	DATE

REV.	APPR. BY	DATE

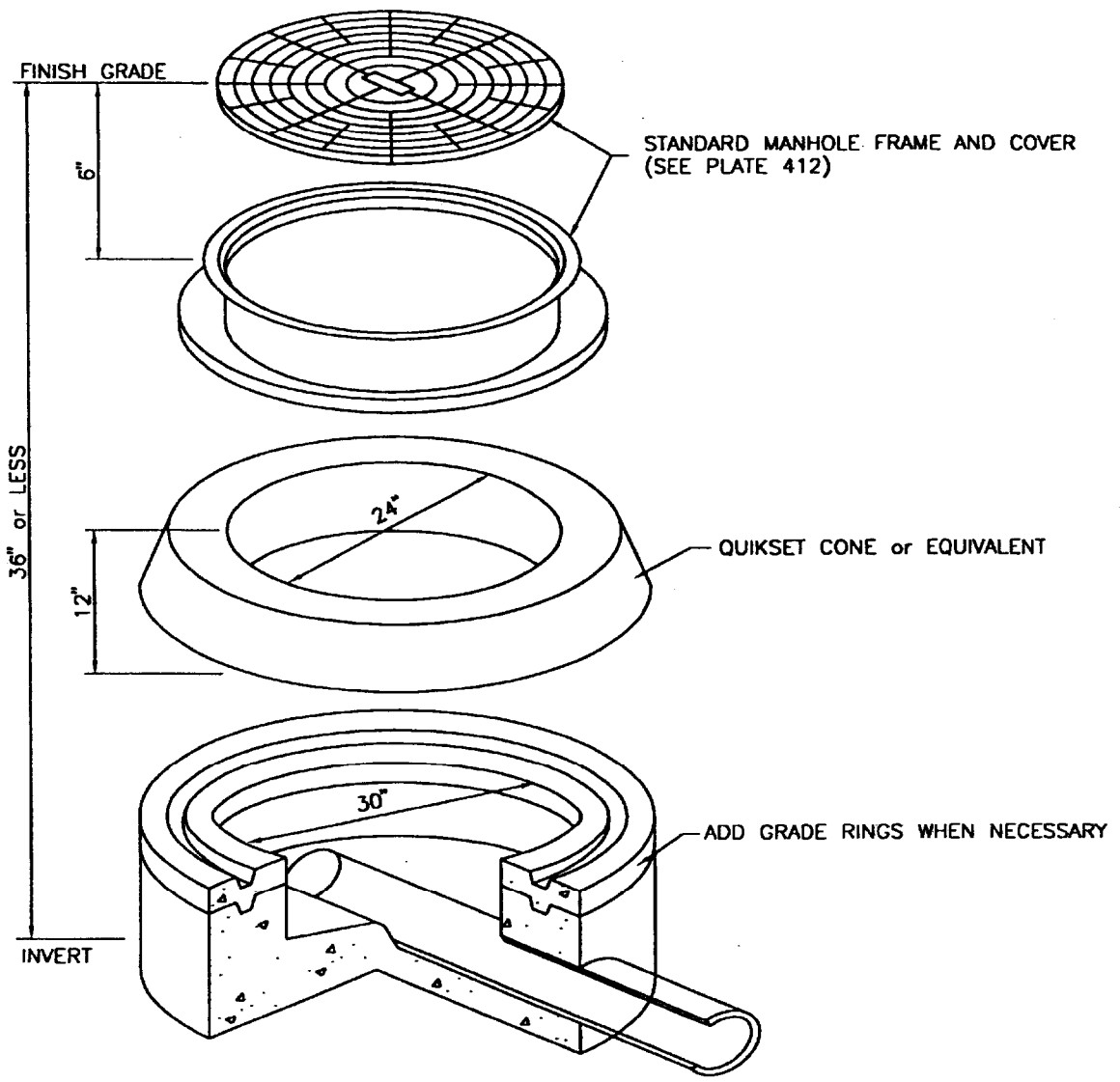

**NOTES:**

1. SEE PLATE 400 FOR ADDITIONAL NOTES NOT MODIFIED BY THIS PLATE
2. USE CONCENTRIC CONES UNLESS OTHERWISE SPECIFIED.

	<b>SHALLOW MANHOLE</b>		STANDARD PLAN 2002
	DRAWN: STAFF Department of Public Works	CKD.: STAFF <i>LB</i>	APPR. <i>Granville M. Bowman</i> Granville M. Bowman