

CURB PROFILE

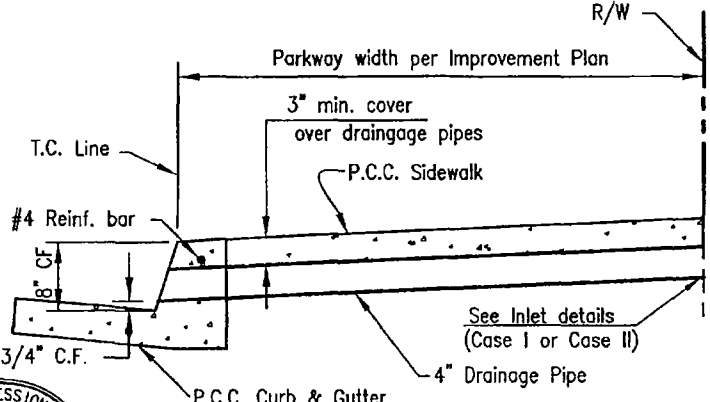

SECTION A-A

NOTES:

1. See Std. Plan 312 for details and notes.
2. Pipes shall be 4" CIP. A.C.P. or Sch. 40 P.V.C. pipe may be substituted upon City Engineer approval.
3. Alhambra Foundry A-470 rectangular cast iron pipe may be substituted at the Contractor's option or as specified on the plans.
4. Cast iron facilities shall have a bituminous coating conforming to AASHTO Designation: M190.
5. Type "C" culvert may be used when inlet velocities are less than 5 fps. or by special permission of the City Engineer.
6. Curb corings for single pipe outlets will be allowed with the permission of City Engineer.
7. For 6" curb heights or less, curb height shall transition to 8" at pipe opening. Transition length shall be 5' min, or as approved by City Engineer.



3-25-04
 DATE APPROVED

Handwritten Signature
 PUBLIC WORKS DIRECTOR/C.E.
Handwritten Signature
 ASSISTANT CITY ENGINEER

CITY OF ORANGE PUBLIC WORKS DEPARTMENT

PARKWAY CULVERT
 TYPE C

STANDARD
 PLAN No.
 311