

CITY OF MISSION VIEJO



INLET TYPE II

STANDARD  
PLAN NO.

402

*Robert Anderson* 9-23-03

APPROVED RCE 30190 DATE

SHT 1 OF 2

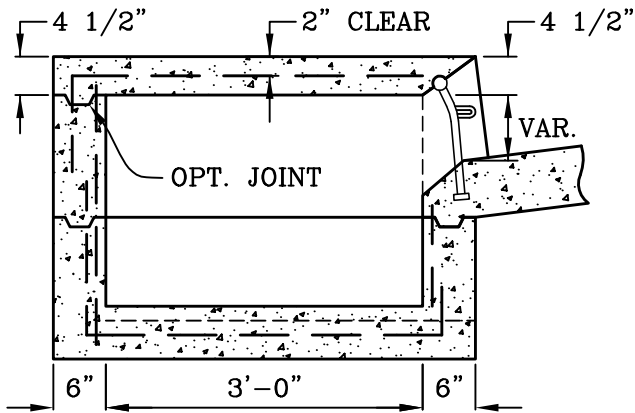

SECTION D-D

NOTES:

1. STANDARD OPENING LENGTHS "L" ARE 7', 10', 14', AND 21'. OTHER LENGTHS MAY BE USED, BUT NOT TO EXCEED 21'.
2. ALL REINFORCEMENT IS #4 @ 12" O.C. UNLESS OTHERWISE SPECIFIED.
3. CURB OPENING SHALL CONFORM TO CURB ALIGNMENT.
4. SEE STD. PLAN 404 FOR DETAILS AND NOTES.
5. SEE STD. PLAN 406 FOR LOCAL DEPRESSION DETAILS.

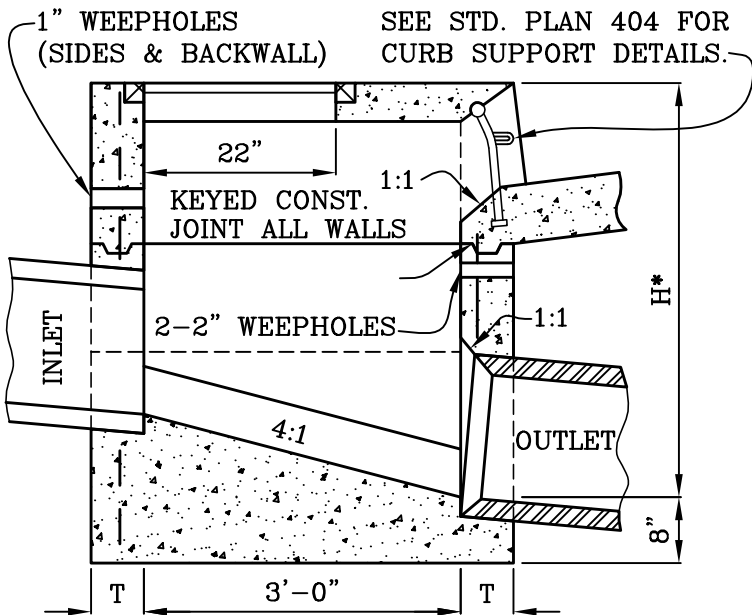

SECTION B-B

H	T	L	MIN. H
8'-0" OR LESS	6"	7'	3.54'
8'-0" TO 20'-0"	8"	10'	3.84'
		14'	4.24'
		21'	4.94'

\*\*ALHAMBRA FOUNDRY A-1531-B, APEX STEEL CORPORATION X110B OR EQUAL WITH APPROVED LOCKING DEVICES. SHIPPING WEIGHT (FRAME & COVER) = 130 LBS.

\*WHEN OUTLET PIPE IS CONSTRUCTED WITHIN ROADWAY, A MINIMUM OF 30" OR THE ROADWAY STRUCTURAL SECTION THICKNESS PLUS 6", WHICHEVER IS GREATER, SHALL BE MAINTAINED BETWEEN THE TOP OF PIPE AND THE ROADWAY SURFACE.

CITY OF MISSION VIEJO

INLET TYPE II

STANDARD PLAN NO.

402



*Robert Anderson* 9-23-03  
 APPROVED RCE 30190 DATE

SHT 2 OF 2