

PLAN - TOP OF COVER
(TRAFFIC SIDE)

PLAN - BOTTOM OF COVER
(SOFFIT / UNDERSIDE)

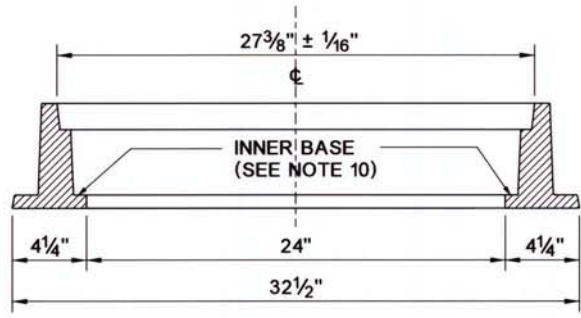

SECTION THRU FRAME

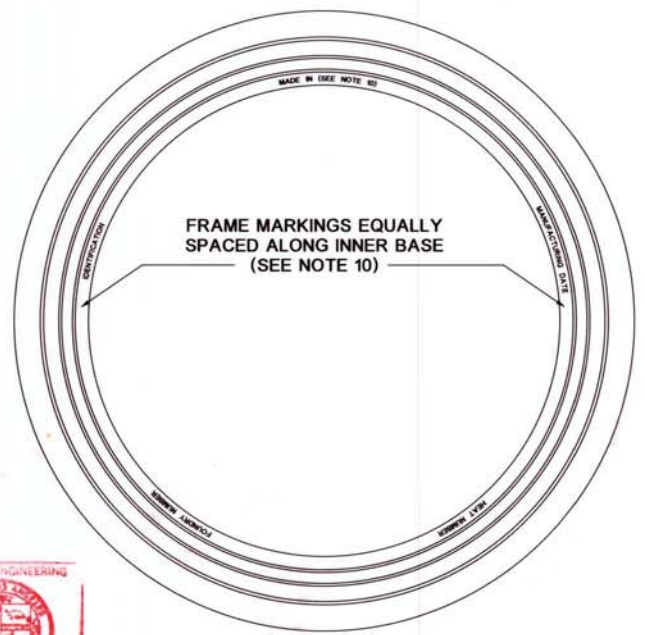

PLAN - TOP OF FRAME

MACHINE FINISH



BUREAU OF ENGINEERING		DEPARTMENT OF PUBLIC WORKS		CITY OF LOS ANGELES	
MAINTENANCE HOLE FRAME AND COVER 24-INCH				STANDARD PLAN S-281-3	
PREPARED	SUBMITTED	APPROVED	SUPERSEDES	REFERENCES	
JONATHAN DE LEON BUREAU OF ENGINEERING CHECKED	 SAMARA ALI-AHMAD, P.E. DATE 6/16/11 ENGINEER OF DESIGN	 GARY LEE MOORE, P.E. DATE 6-16-11 CITY ENGINEER	B-4114	S - 601	
RAFFI A. MASSABKI, P.E. BUREAU OF ENGINEERING	KENNETH R. REDD, P.E. DATE 6/16/11 DEPUTY CITY ENGINEER		VAULT INDEX NUMBER B - 4664		
				SHEET 1 OF 3 SHEETS	

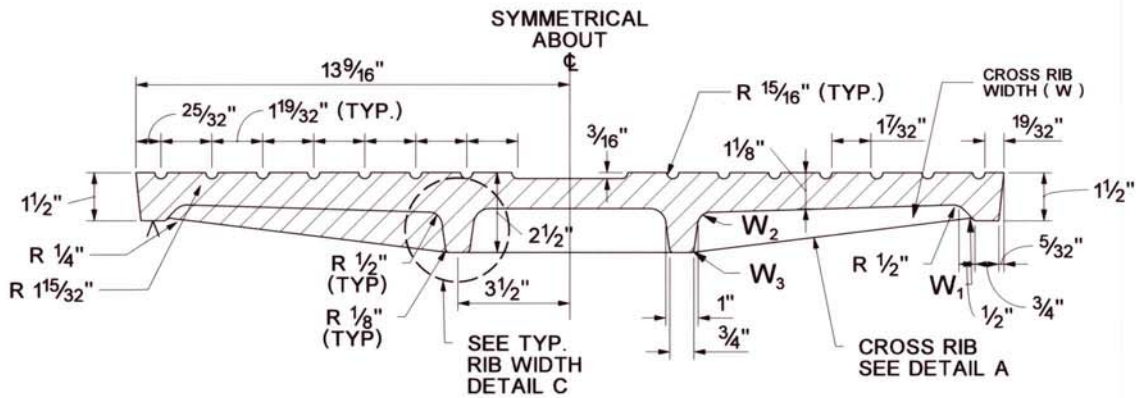

MACHINE FINISH

SECTION "A" COVER

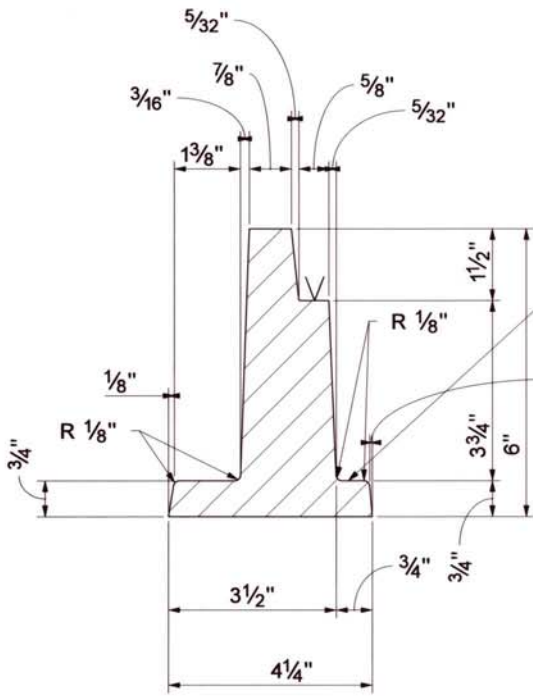

DETAIL OF FRAME

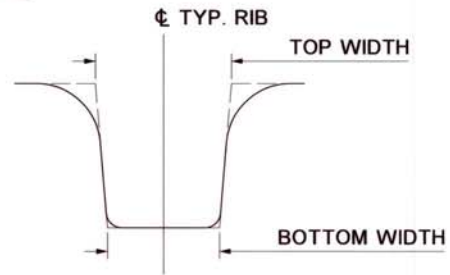

DETAIL C

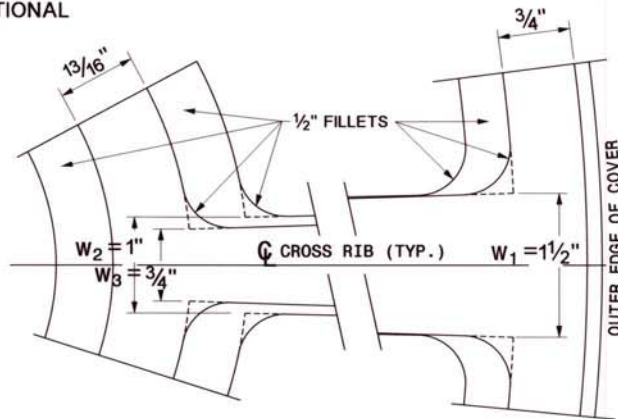

DETAIL A - CROSS RIB

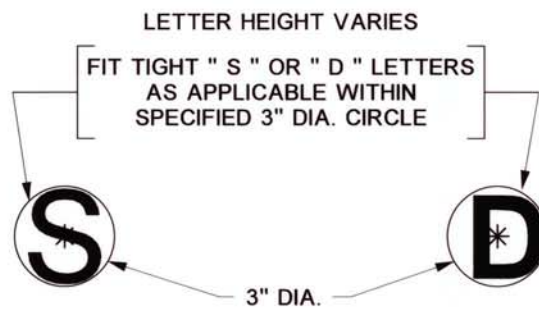

DETAIL B



NOTES

GENERAL

1. MAINTENANCE HOLE FRAME AND COVER SHALL CONFORM TO THE STANDARD SPECIFICATIONS, BROWN BOOK AND THE CITY OF LOS ANGELES STANDARD PLAN S-601 LATEST EDITION. IN CASE OF A CONFLICT BETWEEN THIS STANDARD PLAN "S-281-3" AND OTHER CITY OF LOS ANGELES STANDARD PLANS INCLUDING BUT NOT LIMITED TO STANDARD PLAN "S-601" LATEST EDITION, THIS STANDARD PLAN "S-281-3" SHALL GOVERN.
2. MAINTENANCE HOLE FRAME AND COVER SHALL BE CAST IRON CONFORMING TO SECTION 206-3 OF THE STANDARD SPECIFICATIONS AND SHALL RECEIVE AN ASPHALTIC COATING, AFTER FABRICATION EXCEPT MACHINED SURFACES, CONFORMING TO SECTION 206-3.6 OF THE STANDARD SPECIFICATIONS.
3. ALL HOLES IN CAST IRON SHALL BE DRILLED AFTER CASTING OR PLUGGED PRIOR TO CASTING. THEY SHALL NOT BE PUNCHED.
4. WEIGHT OF MAINTENANCE HOLE FRAME AND COVER SHALL BE PER THE FOLLOWING TABLE :

WEIGHT RANGE	MINIMUM	MAXIMUM
FRAME	250 LBS	- 275 LBS
COVER	175 LBS	- 195 LBS

TESTING

5. MAINTENANCE HOLE FRAME AND COVER SHALL BE TESTED FOR ACCURATE FIT, AND MARKED IN SETS PRIOR TO DELIVERY TO THE JOB SITE.
6. MAINTENANCE HOLE FRAME AND COVER SHALL BE TESTED FOR STRUCTURAL AND IMPACT LOADING, DEFLECTION, LONG TERM ABRASION AND SLIP RESISTANCE IN ACCORDANCE WITH THE CITY OF LOS ANGELES STANDARD PLAN S-601, LATEST EDITION.
7. PROVIDE FABRICATION / BATCH INSPECTION PER SUBSECTION 206-3.2 OF THE STANDARD SPECIFICATION. THE PROOF-LOAD FOR TEST METHOD B, SUBSECTION 206-3.2 OF THE STANDARD SPECIFICATION IS 52,000 LBS.

MARKINGS

8. MAINTENANCE HOLE COVERS FOR USE ON SEWER STRUCTURES SHALL BEAR THE LETTER "S" AND ON STORM DRAIN STRUCTURES THE LETTER "D" LOCATED AT THE CENTER OF THE COVER. SEE DETAIL B ON SHEET 2.
9. MARKINGS LOCATED ON FRAME AND TOP OF COVER SHALL BE FLUSH WITH FINISHED SURFACE. MARKINGS LOCATED ON THE COVER SOFFIT SHALL BE RAISED ABOVE THE ADJACENT FINISHED SURFACE. ETCHING, DIE STAMPING, ENGRAVING OR WELDING ON MARKINGS WILL NOT BE ACCEPTED.
10. COVER TYPE, IDENTIFICATION, FOUNDRY, HEAT NUMBER, MANUFACTURING DATE AND THE ENGLISH NAME OF COUNTRY OF ORIGIN PRECEDED BY "MADE IN" MARKINGS SHALL BE PER THE FOLLOWING TABLE. ALL MARKINGS SHALL BE RAISED, FLAT FACE LETTERS MARKED BY MEANS OF CAST-IN-MOLD LETTERING.

COVER		MARKINGS	FRAME
TOP SURFACE (Traffic side)	BOTTOM SURFACE (Soffit/ Underside)	DESCRIPTION, LOCATION AND SIZE * (Height x Line Width x Depth)	INNER BASE (Exposed side)
IDENTIFICATION		" PRIVATE " or " CITY OF LOS ANGELES "	5/16" X 3/16" X 3/16"
COUNTRY OF ORIGIN		MADE IN " THE ENGLISH NAME OF COUNTRY OF ORIGIN "	5/16" X 3/16" X 3/16"
TYPE of MAINTENANCE HOLE		" S " for Sewer MH " D " for Storm Drain MH	
OTHER		FOUNDRY NAME MANUFACTURING DATE and/ HEAT NUMBER	5/16" X 3/16" X 3/16"
1-1/2" X 1/4" X 3/16"		5/16" X 3/16" X 3/16"	
Height X 1/4" X 3/16" (See Detail B)			

* Adjust spacing, kerning and/or mortising of letters as needed such that letters appear evenly spaced. The minimum spacing between words shall be 1/2 of the letter height specified.

