



83 Years
1923-2006

ALHAMBRA FOUNDRY CO. LTD.

GRAY IRON • STRUCTURAL • MACHINE SHOP

www.alhambrafoundry.com



ALHAMBRA FOUNDRY COMPANY, LTD.



® AFCO is a registered trademark of Alhambra Foundry Co. Ltd.

- GRAY IRON
- ALUMINUM
- BRASS
- STRUCTURAL STEEL FABRICATING
- MACHINE SHOP
- PATTERN SHOP



AREA CODE 626 289-4294 FAX 626 289-3078

1147 MERIDIAN AVENUE / P.O. BOX 469 / ALHAMBRA, CALIFORNIA 91802

COPYRIGHT, 2006

BY

ALHAMBRA FOUNDRY COMPANY, LTD

WE ARE PLEASED TO PRESENT THIS LATEST EDITION
OF OUR CATALOG TO OUR VALUED CUSTOMERS

LITHOGRAPHED IN THE U.S.A. By:



Typecraft Inc.
WOOD & JONES

AREA CODE 626 289-4294 FAX 626 289-3078



Since 1923 the construction industry in the southwest has relied upon Alhambra Foundry Co., Ltd. for **all** types of miscellaneous metalwork-castings and fabrications, custom or standard

This twenty-third edition of our catalog is dedicated to serving the needs of architects, engineers, and contractors who have been responsible for the development and growth of our product line.

We shall strive to merit by helpfulness, dependability, and quality, your inquiries for construction metalwork whether or not shown in this catalog.

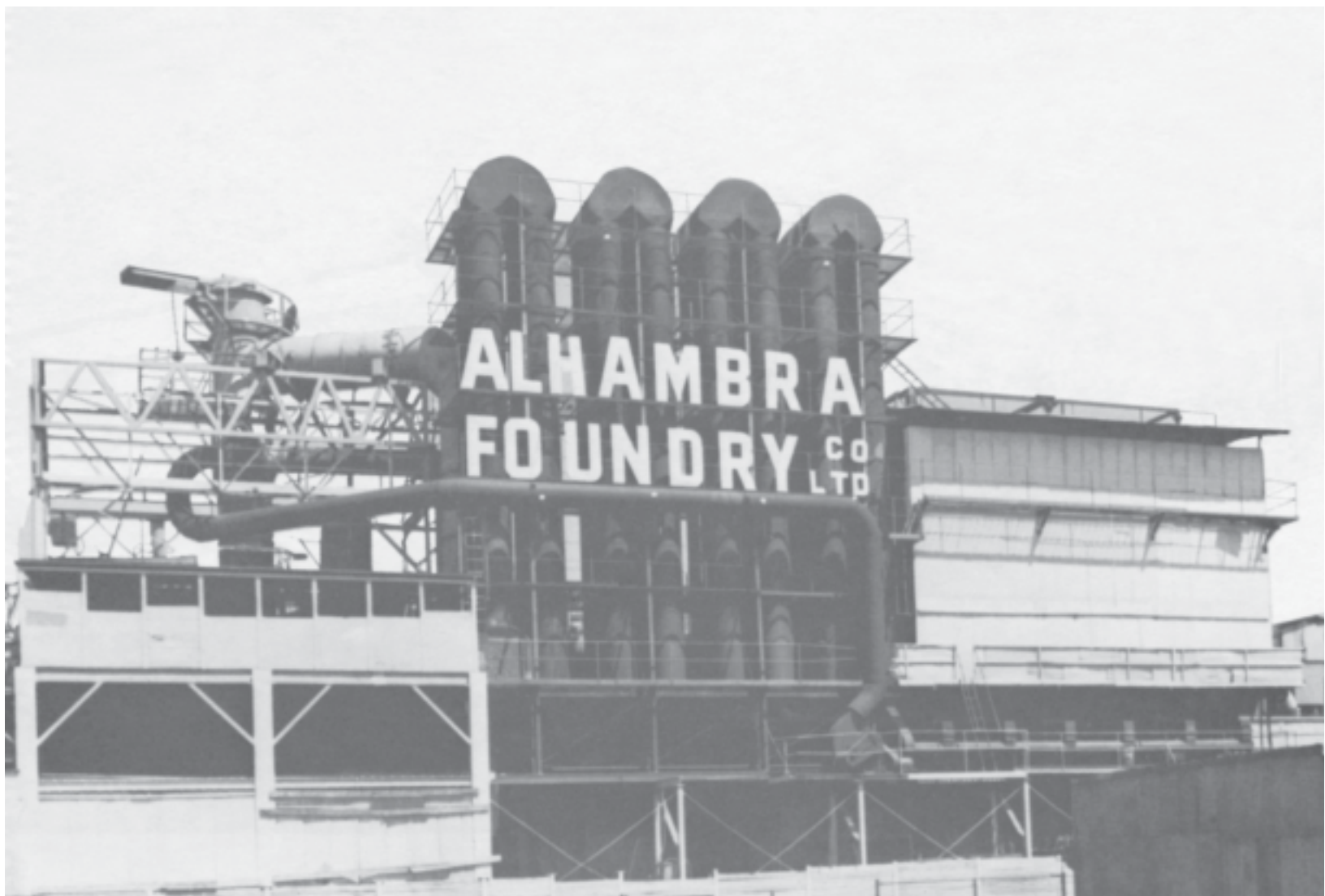



FOUNDRY

Though production is built around a line of construction castings, our foundry has always specialized in general jobbing castings.

It has facilities for all types of low to medium volume production — light, medium, and moderately heavy. A staff with many years experience is eager to help in application, design, and pattern making for all types of cast and process irons.

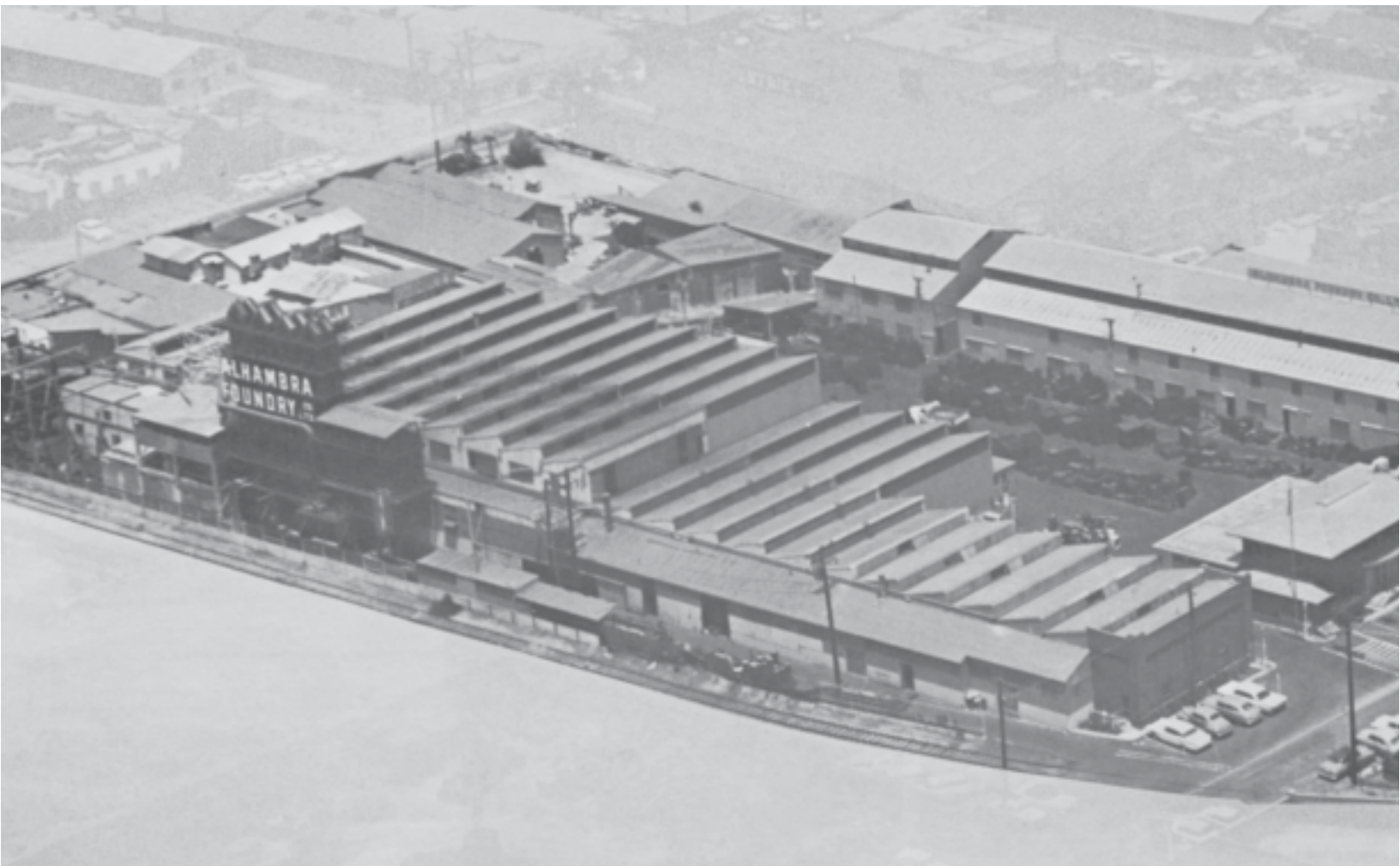



METAL FABRICATING

Our Fabricating Division specializes in the fabrication of materials for the construction industry. Complete metal service from one source facilitates construction and streamlines job progress. Our service includes forming, cutting, shearing, and welding shapes and plates in steel and aluminum to meet your specifications.





FOUNDRY

Our mechanized foundry with advanced production methods offers one of the largest selections of foundry products on the West Coast.

We service all phases of the construction industry — water pollution control, underground utilities, recreation facilities, environmental improvements, and construction equipment.

MACHINE SHOP

Our completely integrated metal working plant includes facilities for general machining: vertical boring mills, engine lathes, radial drill presses, milling machine and shaper.

This equipment makes possible a total service of casting and machining where required.





SPECIFICATIONS

To which ALHAMBRA FOUNDRY CO. LTD. construction castings shall conform — to insure consistent high quality and dependability.

GENERAL QUALITY CONDITIONS

ALHAMBRA FOUNDRY CO. LTD. castings shall be of uniform quality, free from blow holes, porosity, hard spots, shrinkage, distortion or other defects. The finish shall meet industry standards and be well cleaned by shotblasting.

MATERIALS

ALHAMBRA FOUNDRY CO. LTD. gray iron castings shall conform to the requirements of AASHTOM105 / ASTM A48 class 35B or ASTM 48 class 30.

Ductile iron castings shall conform to the requirements of ASTM A536.

GRAY IRON

DUCTILE IRON

SPECIFICATION	SPECIFICATION NUMBER	IRON CLASS	MINIMUM TENSILE STRENGTH
ASTM FEDERAL	A-48	30	30,000
	RR-F-621C (A-A-60005)	30	30,000
ASTM	A-536	64-45-12	65,000

RECYCLE / REUSE (Environmental Policy)

ALHAMBRA FOUNDRY CO. LTD. is committed to be a responsible partner in environmental progress.

We recycle ferrous scrap into useful products as well as reclaim and reuse the byproducts in our plant or provide to industries which recycle and reuse them.

NOTE: Unless alternate metal specification is designated, all castings shall conform to one of the specifications in the above tables.

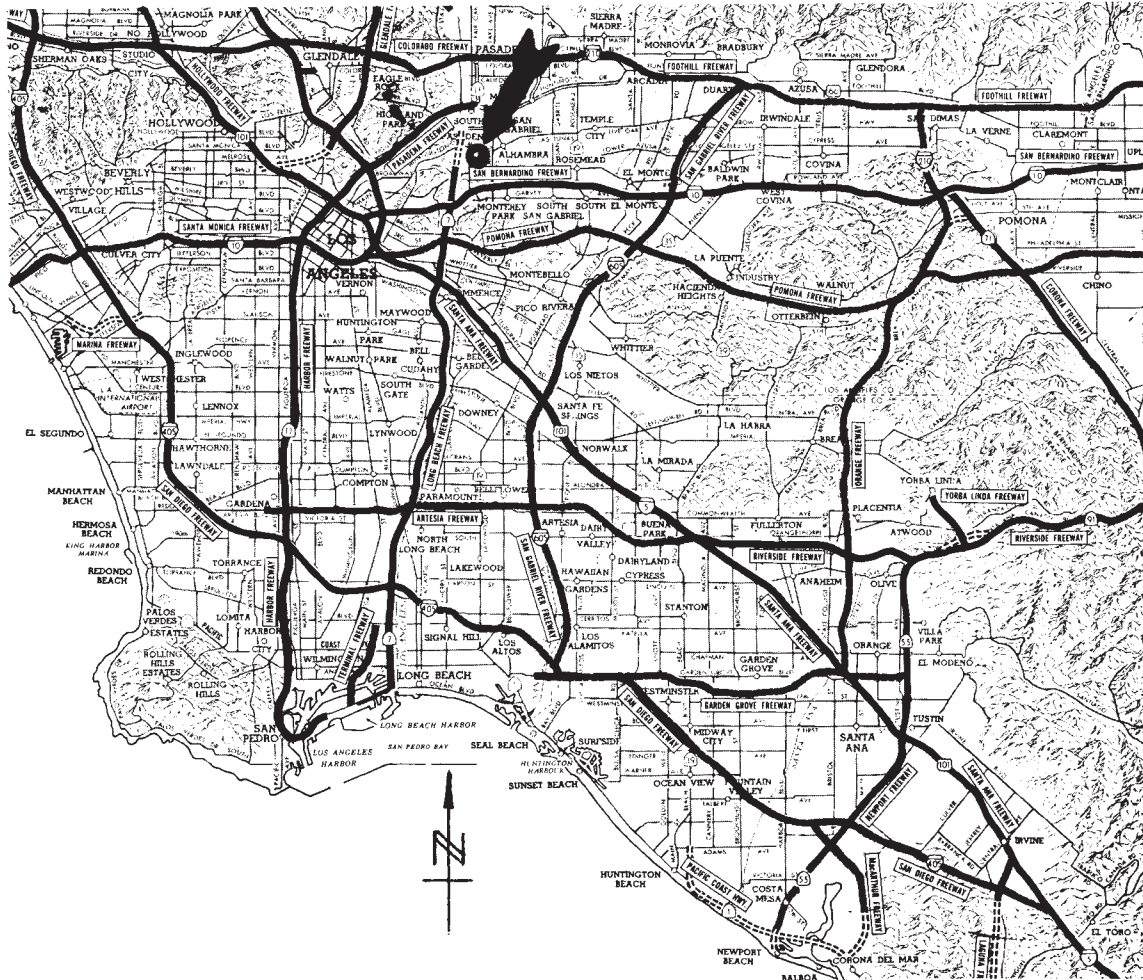
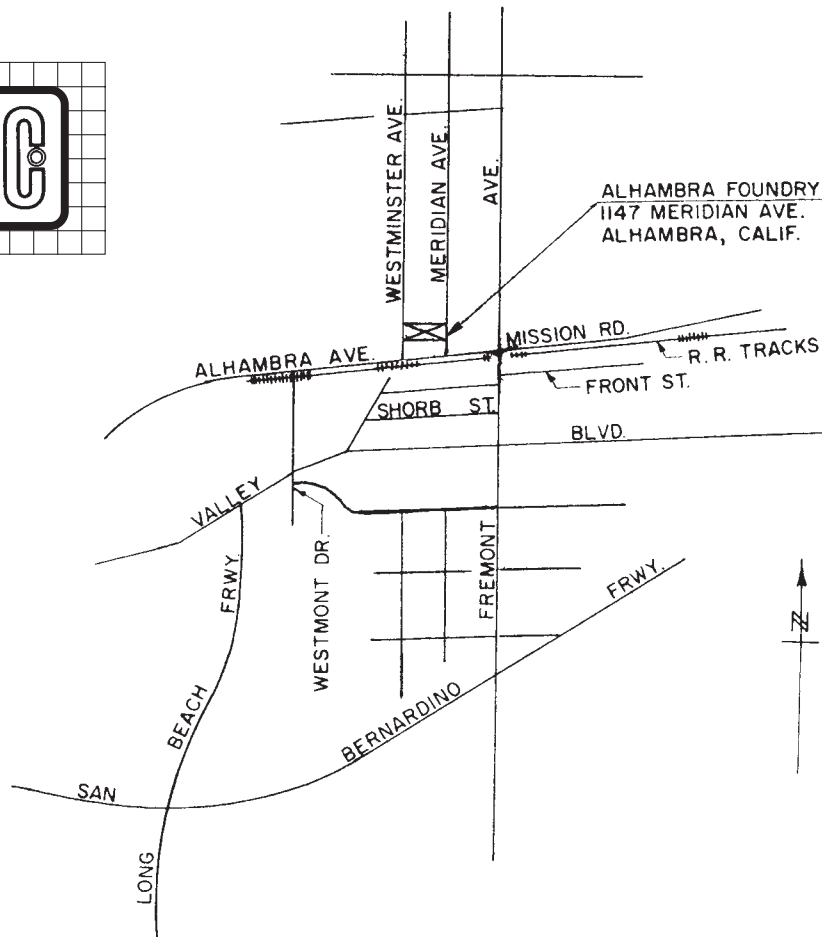



CONTENTS

Manhole Covers & Frames	SECTION	A
Manhole & Vault Hardware	SECTION	B
Rectangular Covers, Grates & Frames	SECTION	C
Misc. Engineering Construction Castings & Hardware	SECTION	D
Building Construction Casting Hardware	SECTION	E
Electrical Castings & Hardware	SECTION	F
Misc. Products	SECTION	G
Alphabetical and Numerical Index	SECTION	H



DEFINITION OF SYMBOLS AND TERMS

ORDERING	To minimize error: We suggest orders state part number, principal dimensions, and catalog page.
★	Signifies more favorable stock availability and volume production costs.
'B'	The letter 'B' following a part number indicates the cover is bolted to the frame.
DIMENSIONS	Dimensions are all given in inches unless otherwise stated. Dimensions in the catalog are subject to manufacturers' tolerances.
ILLUSTRATION	All illustrations, descriptions, and detailed dimensions describe standard features and do not indicate any variation available.
WEIGHT	All weights are approximate and in pounds unless otherwise noted.
MACHINED SEATS	Has reference to the cover and frame machined to full bearing contact.
GROUND TO FIT	Fitting of frame to cover is accomplished by use of grinding pads.
TRAFFIC	Satisfactory for roadway or highway traffic, H-20 loading.
NON-TRAFFIC	Recommended for pedestrian sidewalks and terraces.



CONDITIONS OF SALE

TERMS OF PAYMENT	Net 30 days. Accounts over 30 days are subject to 1½ % per month interest.
SALES TAX	Federal, State or local taxes, if applicable, will be added to net catalog or quoted prices.
MINIMUM INVOICE	\$50.00. Please use cash purchase or combined orders to minimize processing costs.
PRICE LISTS	Quoted f.o.b. our plant and subject to change without notice.
WARRANTY AND LIMITATIONS	All products of the Alhambra Foundry Company are warranted to the extent that we will replace those having manufacturing defects when used in the service for which we recommend for a period of one year from the date of delivery. No allowance for labor or damage will be honored.
BACK CHARGES	No back charges will be accepted unless given in writing within 10 days of receipt of material, and then only upon our approval in writing.
RETURNED GOODS	Permission to return material for credit must be obtained from the Alhambra Foundry Company in writing. Credit allowed on standard stock items only under the following terms— A. 20% minimum handling charge B. Determination of credit allowable is subject to review upon receipt of material C. Freight collect shipments not accepted D. No material will be accepted after one year period.
FREIGHT CLAIMS	All claims for breakage, loss, and damage should be made to carriers. We will gladly render all possible assistance in securing satisfactory adjustments of such claims.
CANCELLATION OR CHANGES	Orders are not subject to cancellation or change without our consent. Upon agreement of payment for special work performed, cancellation or change will be processed.
DELAYS	We will accept no charges for delayed delivery unless a written stipulation of the extent of our liability has been given at the time of accepting the order.
EXPORT	Packing, as required for export, will constitute an additional charge above quoted prices.
CHANGES IN STANDARDS	We reserve the right to make any changes which in our opinion will improve the product and will make every effort to furnish any material ordered from this catalog in accordance with the standards current at the time the order is filed.
DISCLAIMER	Alhambra Foundry Co. Ltd. will not be responsible for installation and/or maintenance of any of its products. It is the sole responsibility of the buyer, contractor, and final property owner to ensure correct product selection for the intended use, as well as installation and maintenance of the products in full compliance with all applicable city, county, state, and federal specifications.

SECTION

A



A

MANHOLE COVERS and FRAMES

Sewer and Electrical

Sewer M.H. Cover and Frame	Lamphole Cover and Frame
Drainage M.H. Cover and Frame	Survey Monument Cover and Frame
Water M.H. Sealed Cover and Frame	Telephone Cover and Frame
Pressure M.H. Cover and Frame	Electrical M.H. Frame and Cover with Inner Pan
M.H. Cover Raising Rings	Vault Covers and Frames



ALHAMBRA FOUNDRY COMPANY, LTD.
www.alhambrafoundry.com

ALHAMBRA FOUNDRY PRODUCTS BEAR THIS MARK

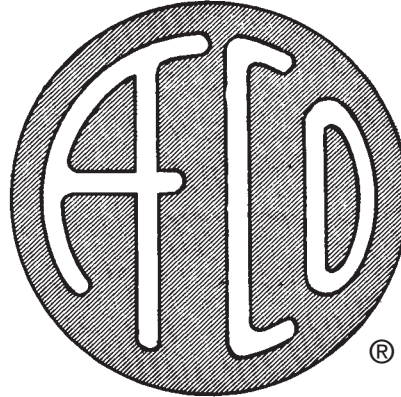
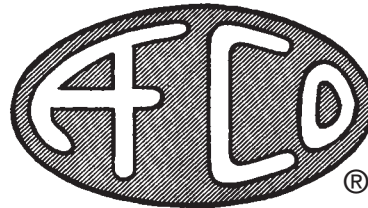

® AFCO is a registered trademark of Alhambra Foundry Co. Ltd.



**MANHOLE COVER AND FRAME
FOR TRAFFIC**

PLATE NUMBER	CLEAR OPENING	OVERALL BASE	HEIGHT FRAME	APPROX. WEIGHT
★ A-1251-4*	36	44	4	520
★ A-1251-6*	36	44	6	580
★ A-1252	30	38	6	430

Diamond Tread. Covers and Frames Machined to Fit. Covers Lettered to Suit Requirements and Supplied with Blind Lift Pocket. Bituminous Painted.
NOTE: Open Grating Can Be Furnished in Lieu of Solid Cover.

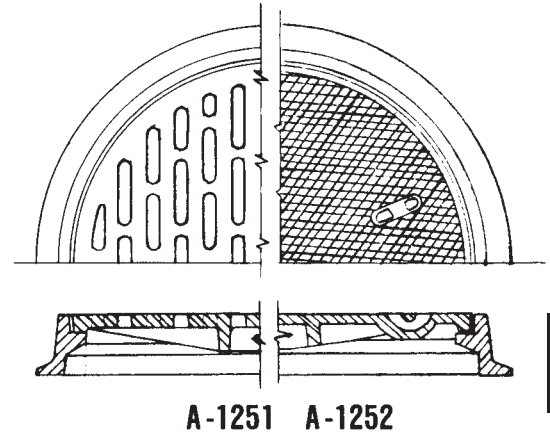

**MANHOLE COVER AND FRAME
FOR TRAFFIC**

PLATE NUMBER	CLEAR OPENING	OVERALL BASE	HEIGHT FRAME	APPROX. WEIGHT
A-1253	26	34	4	360
★ A-1254†	24	32	3½	320
★ A-1254-6†	24	33	6	335
A-1255	20	26	3	195
A-1256	18	24	3	160
A-1259	23½	29	3	205

Diamond Tread. Covers and Frames Machined to Fit. Covers Lettered to Suit Requirements. Painted: Bituminous Paint and Supplied with Blind Lift Pocket.
NOTE: Open Grating Can Be Furnished in Lieu of Solid Cover.

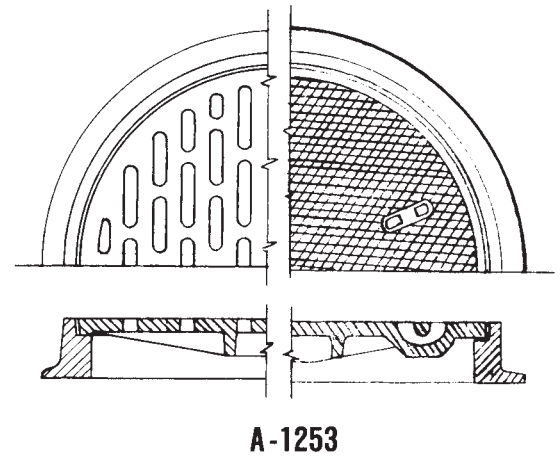

**MANHOLE COVER AND FRAME
NON-TRAFFIC**

PLATE NUMBER	CLEAR OPENING	OVERALL BASE	HEIGHT FRAME	APPROX. WEIGHT
★ A-1261-4*	See A-1251 above			
★ A-1261-6*	See A-1251 above			
★ A-1262	30	38	3	300
A-1263	26	34	4	240
A-1264	24	32	3½	250
A-1265	20	26	3	195
A-1266	18	24	3	160

Diamond Tread. Covers and Frames Machined to Fit. Covers Lettered to Suit Requirements. Painted: Bituminous Paint and Supplied with Blind Lift Pocket.
NOTE: Open Grating Can Be Furnished in Lieu of Solid Cover.

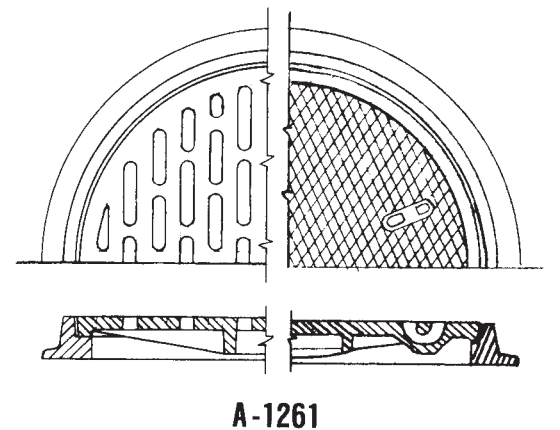

* Can be furnished with radial block tread
† Radial block tread only
★ — signifies more favorable stock and volume production



**WATER-TIGHT MANHOLE COVER AND FRAME
FOR TRAFFIC**

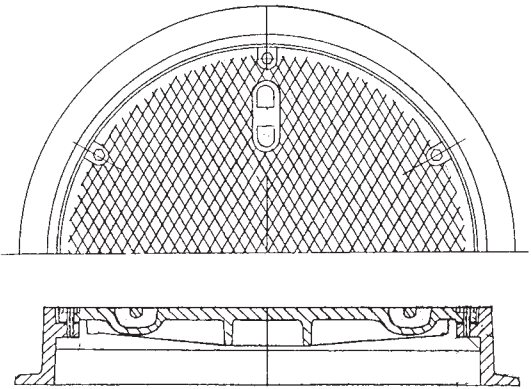

A-1250B

PLATE NUMBER	CLEAR OPENING	OVERALL BASE	HEIGHT FRAME	NUMBER CAP SCREWS	APPROX. WEIGHT
A-1251B-4*	36	44	4	8	520
A-1251B-6*	36	44	6	8	580
A-1252B	30	38	6	6	430
A-1253B	26	34	4	6	360
A-1254B†	24	32	3½	6	305
A-1254B-6†	24	33	6	6	425
A-1255B	20	26	3	4	195
A-1256B	18	24	3	4	160

Diamond Tread. Covers and Frames are Machined. Fitted with Composition Gasket and Bolted Down with Stainless Steel Cap Screws. Covers are Supplied with Blind Lift Pockets. Lettered Designation to Suit. Painted: Bituminous Paint.

**WATER-TIGHT MANHOLE COVER AND FRAME
NON-TRAFFIC**

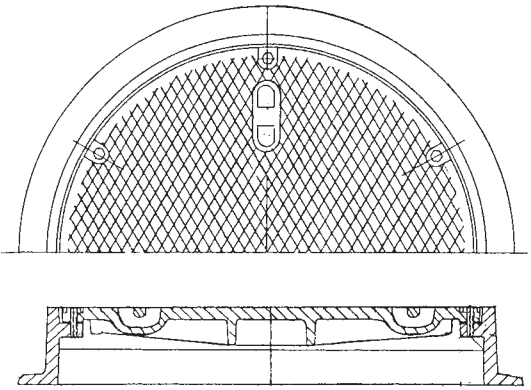

A-1260B

PLATE NUMBER	CLEAR OPENING	OVERALL BASE	HEIGHT FRAME	NUMBER CAP SCREWS	APPROX. WEIGHT
A-1261B-4*	See A-1251B above				
A-1261B-6*	See A-1251B above				
A-1262B	30	38	3	6	300
A-1263B	26	34	4	6	240
A-1264B	24	32	3½	6	250
A-1265B	20	26	3	4	195
A-1266B	18	24	3	4	160
A-1268B	12	19	2¾	4	75

Diamond Tread. Covers and Frames are Machined. Fitted with Composition Gasket and Bolted Down with Stainless Steel Cap Screws. Covers are Supplied with Blind Lift Pockets. Lettered Designation to Suit. Painted: Bituminous Paint.

**WATER-TIGHT COVER AND FRAME
FOR TRAFFIC FOR OVER FUEL OR BLOW-OFF TANKS**

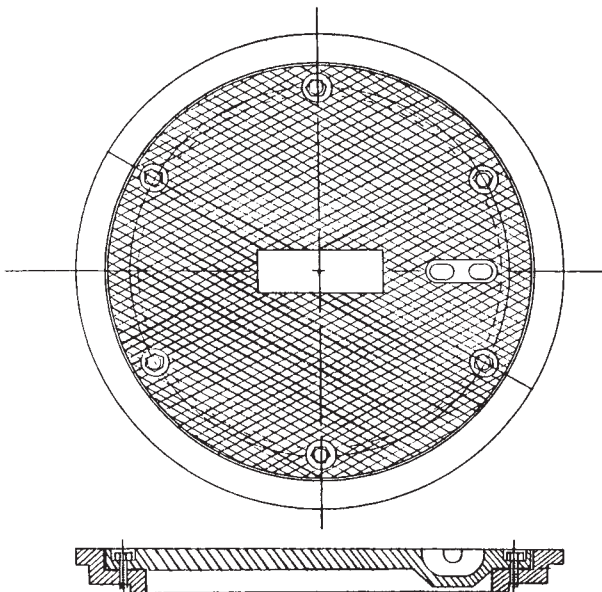

A-1520

PLATE NUMBER	CLEAR OPENING	OVERALL BASE	HEIGHT FRAME	NUMBER CAP SCREWS	APPROX. WEIGHT
A-1520-B	36	44	4	8	520
A-1521-B	24	34	3½	8	400
A-1522-B	30	40	3½	8	523

Covers and Frames are Machined. Fitted with Neoprene Gasket and Bolted Down with Stainless Steel Cap Screws. Covers are Supplied with Blind Lift Pockets. Lettered to Suit. Painted: Bituminous Paint.

*Can Be Furnished with Radial Block Tread. †Raised Block Tread Only.



**MANHOLE COVER AND FRAME
FOR TRAFFIC**

PLATE NUMBER	CLEAR OPENING	OVERALL FLANGE	HEIGHT	APPROX. WEIGHT
A-1490	23 1/4	31 3/4	6	475
A-1491 — Inner Pan				80
A-1492 — Furnished with Grating				460
A-1493	33	48	6	840
A-1499	24	31 3/4	6	475

Radial Block Tread. Cover and Frame Machined to Fit. Painted: Bituminous Paint. Letter Designation to Suit.

NOTE: Above Also Furnished with Inspection Hole. See A-1494, Page A-13.
A-1499 Conforms to State of California Standard. U-45.

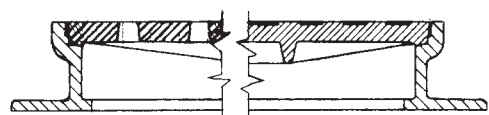
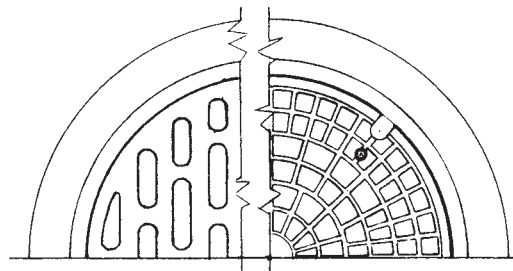

A-1492 — A-1490

**MANHOLE COVER AND FRAME
FOR TRAFFIC
A.P.W.A. - A.G.C. Standard**

PLATE NUMBER	CLEAR OPENING	OVERALL FLANGE	HEIGHT	APPROX. WEIGHT
★ A-1495	24	32 1/2	6	450
A-1496	27	35 1/2	6	519
A-1497	30	38 1/2	6	628
A-1498	36	44 1/2	6	900
A-1503	24	34	4	470

Radial Block Tread. Cover and Frame Machined to Fit. Painted: Bituminous Paint. Letter Designation to Suit.

Conforms to City of Los Angeles Plans 281-2, 282-1, 283-2, 286-0, 286-1, and Los Angeles County Flood Control Plan 2-D472.

NOTE: A-1503 Conforms to County Sanitation District Sa228 but not for pressure applications.

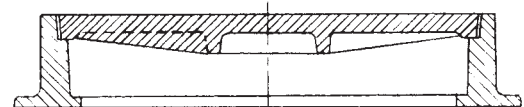
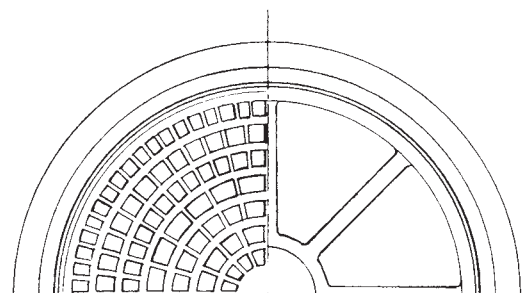

A-1495

**PRESSURE MANHOLE COVER AND FRAME
FOR TRAFFIC**

PLATE NUMBER	CLEAR OPENING	OVERALL FLANGE	HEIGHT	APPROX. WEIGHT
A-1500*	22 1/2	31 3/4	6	525
A-1501	33	48	6	990
A-1502†	28 1/2	40 1/4	6	650

Radial Block Tread. Lettered to Suit. Has 5/16" Thick Steel Inner Pressure Plate Fastened with 12 Bronze or Stainless Studs or Cap Screws and has Gasket between Plate and Frame. All Seats of Cover and Pressure Plate are Machined to Fit. 12—5/8" x 8" Anchor Bolts with Washers Furnished Unless Otherwise Specified. Painted: Bituminous Paint.

*Conforms to City of Los Angeles Design No. B-1842 and Los Angeles County Flood Control Design 2-D197.

NOTE: A-1501 Pressure Plate 1/2 inch thick, fastened with 24 Stainless Steel Studs.

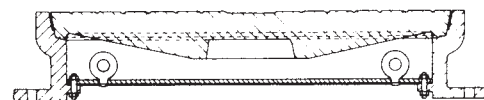
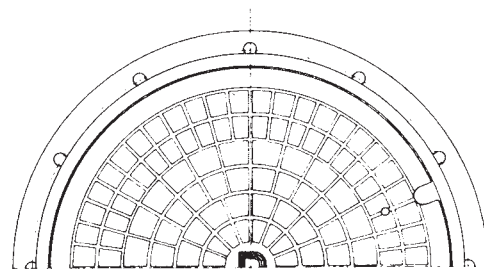

A-1500

† Conforms to City of Los Angeles S-284-2

★ — signifies more favorable stock and volume production

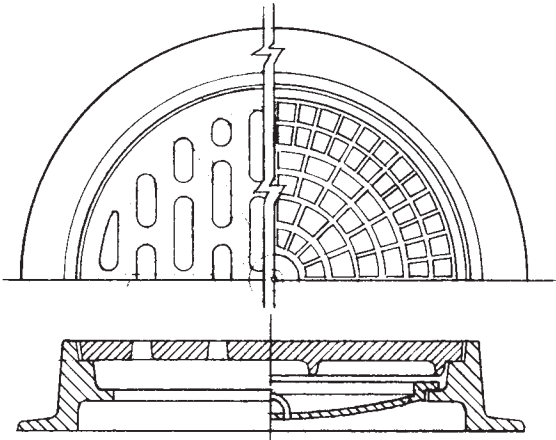

A-1171 — A-1170

**MANHOLE COVER AND FRAME
FOR TRAFFIC**

PLATE NUMBER	CLEAR OPENING	OVERALL FLANGE	HEIGHT	APPROX. WEIGHT
★A-1170	22½	33¼	6	435
A-1171 — Same as above with Grate	-----	-----	-----	375
A-1172 — Inner Pan	-----	-----	-----	70

Radial Block Tread. Covers and Frames Machined to Fit. Painted: Bituminous Paint. Letter Designation to Suit.

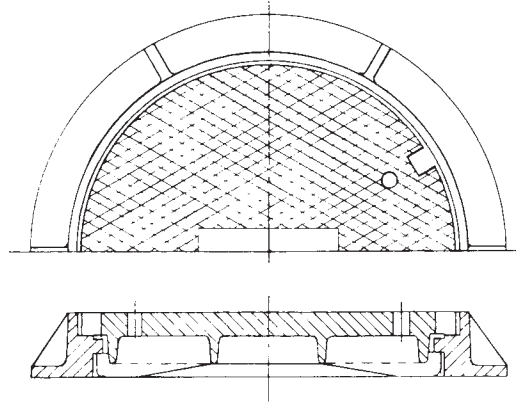

A-1176

**MANHOLE COVER AND FRAME
LOCKING TYPE
FOR TRAFFIC**

By turning the cover but a few degrees engages two fingers on the cover along an inclined plane on the frame, locking or releasing the cover.

PLATE NUMBER	CLEAR OPENING	OVERALL FLANGE	HEIGHT	APPROX. WEIGHT
A-1175	22¾	30¼	4⅞	365
★A-1176*	24	31¾	4⅞	365

Diamond Tread. Covers and Frames Machined to Fit. Painted: Bituminous Paint. Letter Designation to Suit.

*Conforms to County Sanitation District Drawing S-a-207 and Los Angeles County Drawing S-35.

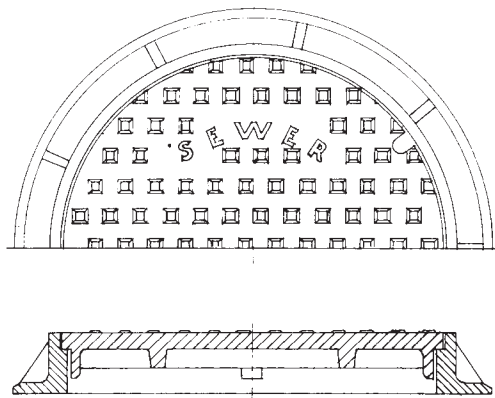

A-1270

**MANHOLE COVER AND FRAME
FOR TRAFFIC**

PLATE NUMBER	CLEAR OPENING	OVERALL FLANGE	HEIGHT	APPROX. WEIGHT
A-1270	23½	34	6	440

Square Block Tread. Cover Guides. Five ¾" Round Vent Holes. Covers and Frames Machined to Fit. Painted: Bituminous Paint. Lettered Designation to Suit.

★ — signifies more favorable stock and volume production



**MANHOLE COVER AND FRAME
WITH LOCKING INNER PAN
FOR TRAFFIC**

PLATE NUMBER	CLEAR OPENING	OVERALL FLANGE	HEIGHT	APPROX. WEIGHT
A-1505	24	39	8	600

Low Pressure Gas, Water and Steam Manhole. Diamond Tread. Seats of Cover and Pressure Plate Machined to Fit. Painted: Bituminous Paint.

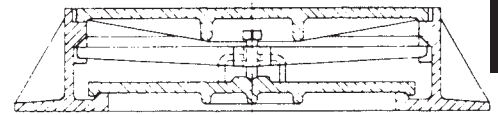
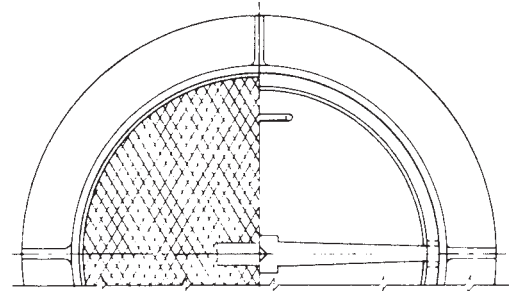

A-1505



**MANHOLE COVER AND FRAME
FOR TRAFFIC**

PLATE NUMBER	CLEAR OPENING	OVERALL FLANGE	HEIGHT FRAME	APPROX. WEIGHT
A-1329	24	35	7	440

Diamond Tread. Extra Heavy Cover. Designed for Heavy Traffic. Machined Seats. Painted: Bituminous Paint. Conforms to Federal Specification RR-F-621 Fig. 1.

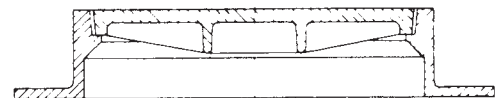
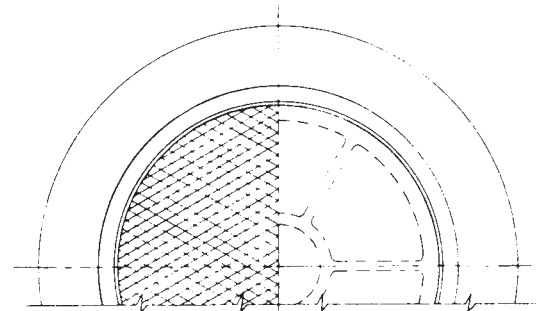

A-1329

**MANHOLE COVER AND FRAME
NON-TRAFFIC**

PLATE NUMBER	CLEAR OPENING	OVERALL FLANGE	HEIGHT FRAME	APPROX. WEIGHT
A-1328	24 $\frac{3}{4}$	28	4	190

Diamond Tread. Designed for Light Traffic. Machined Seats. Painted: Bituminous Paint. Conforms to Federal Specification RR-F-621 Fig. 10.

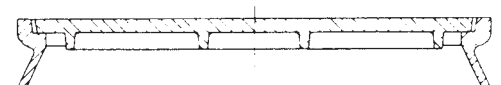
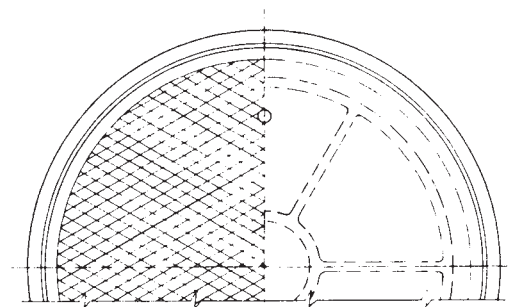

A-1328



**NAVY STANDARD MANHOLE COVER AND FRAME
FOR TRAFFIC
SPECIFICATION 42Ya — PLATE NO. 12**

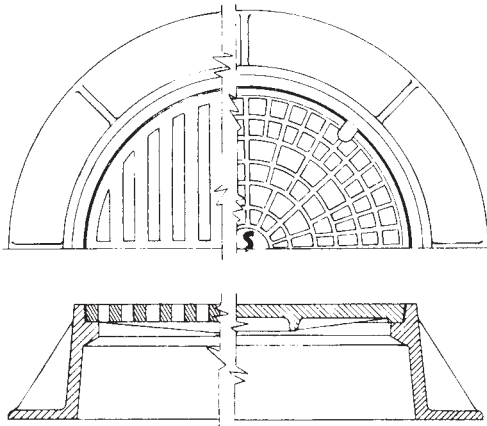

Spec. 42Ya — Plate No. 12

PATTERN NUMBER	AREA USED	CLEAR OPENING	OVERALL BASE	HEIGHT FRAME	APPROX. WEIGHT
1	Paved	20½	36	9	460
2	Unpaved	20½	36	9	330
4	Paved	23	38	9	500
5	Unpaved	23	35	7½	400

For Pattern No. 3, See Page A-22 — No. A-1513.
Covers for Storm Manholes to Be Solid or Perforated as Specified. Machined Cover Seats. Painted: Bituminous Paint. NOTE: Open Grating can be Furnished in Lieu of Solid Cover.

**MANHOLE COVER AND FRAME
FOR TRAFFIC
(EXCEPT AS NOTED)**

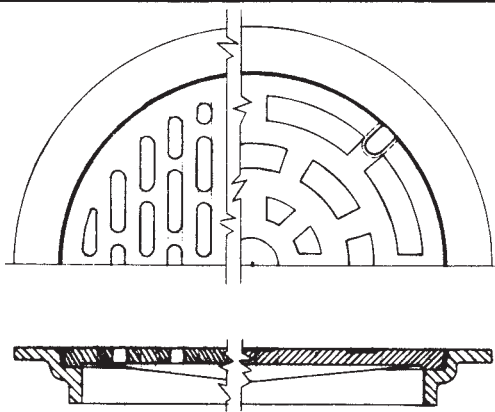

A-1420

PLATE NUMBER	CLEAR OPENING	OVERALL TOP	HEIGHT	COVER THICKNESS	APPROX. WEIGHT
A-1420-4	36	44	4	1¼	480
A-1420-6	36	44	6	1¼	625
A-1421	30	39½	4	1¾	475
A-1422	24	33½	5	2½	495
A-1424*	24	33½	4	1¼	300
A-1425†	24	28½	3	1	190
A-1427	27	36½	4	1½	555

Special Tread. Machined Seats. Painted: Bituminous Paint.
NOTE: Open Grating Can Be Furnished in Lieu of Solid Cover.
*Conforms: Navy—Patt. No. 6, Plate No. 13.
†Non-Traffic.

**P.W.O. STANDARD MANHOLE COVER AND FRAME
FOR TRAFFIC
U.S. NAVAL BASE — SAN DIEGO, CALIF.**

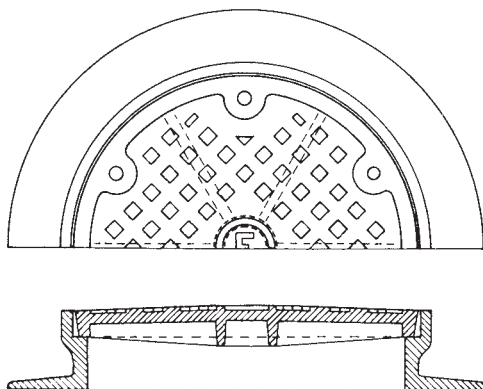

A-1320

PLATE NUMBER	NAVY DRAWING	CLEAR OPENING	OVERALL BASE	HEIGHT FRAME	APPROX. WEIGHT
A-1320	F-10-5-S30	24	36	6	432
A-1321	10-5-124	27	39	6½	510
A-1322	F-10-5-S31	30	46	8	700

For Navy Dwg. F-10-5-S29—42" Opening. See Page A-21, Plate No. A-1323. Square Block Tread. Machined Cover Seats. Letter Designation to Suit Requirements. Painted: Bituminous Paint.



**MANHOLE COVER AND FRAME
FOR TRAFFIC**

PLATE NUMBER	CLEAR OPENING	OVERALL FLANGE	HEIGHT FRAME	APPROX. WEIGHT
A-1310	22	31	4	380
A-1311*	22	29	4	325

Raised Block Tread. Lift Holes. Cover and Ring Machine Fit.
Painted: Bituminous Paint.
*City of Las Vegas Std.

A-1310 Conforms to San Diego Regional Standard M-1.

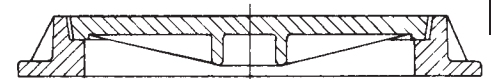
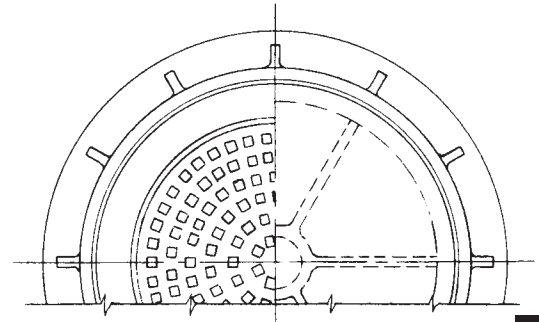

A-1310



**MANHOLE COVER AND FRAME
FOR TRAFFIC**

PLATE NUMBER	CLEAR OPENING	OVERALL BASE	HEIGHT FRAME	APPROX. WEIGHT
A-1312	21¾	31¾	5	380
A-1314 — Inner Pan	—	—	—	41
A-1315*	22½	30	4	290

Raised Block Tread. Machined Seats. Painted: Bituminous Paint.
*Not Available with Inner Pan.

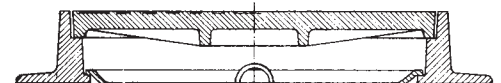
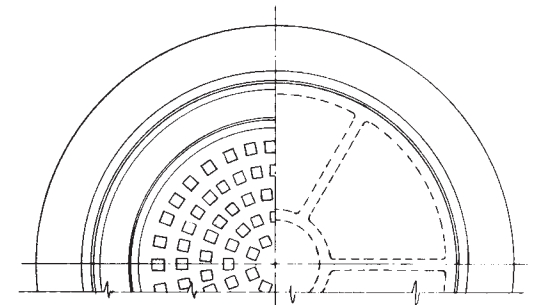

A-1312

**SPECIAL MANHOLE COVER AND FRAME
LARGE DIAMETER FLANGE
FOR TRAFFIC**

PLATE NUMBER	CLEAR OPENING	OVERALL FLANGE	HEIGHT FRAME	APPROX. WEIGHT
A-1327	24	40	4¼	500

Diamond Tread. Special Large Extra Heavy Flange Diameter to Fit 36" Manhole Shaft.
Machined Seats. Painted: Bituminous Paint.

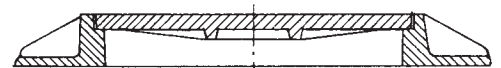
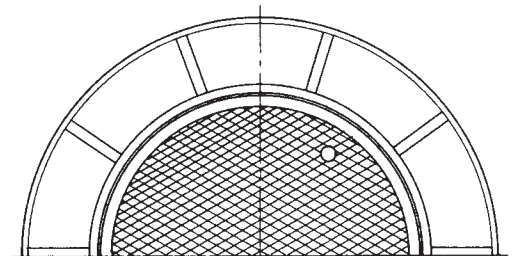

A-1327

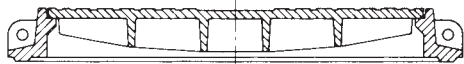
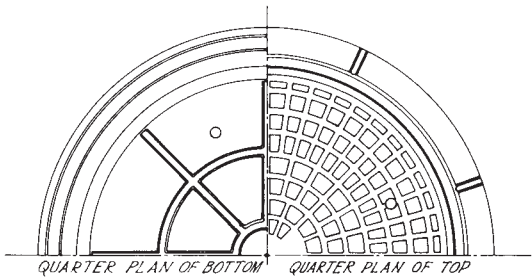

A-1480

**MANHOLE COVER AND FRAME
FOR TRAFFIC**
Conforms to Metropolitan Water District Standard

PLATE NUMBER	CLEAR OPENING	OVERALL FLANGE	HEIGHT	APPROX. WEIGHT
A-1480	34 1/4	43 1/2	4 3/4	610

Radial Block Tread. Painted: Bituminous Paint. Cover and Ring Machined to Fit. Can be modified to the Metropolitan Water Dist. Dwg. No. A-4244.

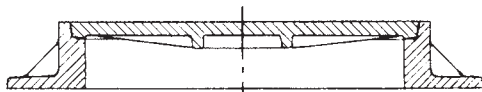
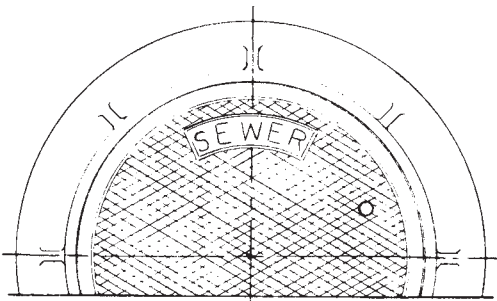

A-1590

**MANHOLE COVER AND FRAME
FOR TRAFFIC**
Conforms to East San Bernardino County Water District Design

PLATE NUMBER	CLEAR OPENING	OVERALL FLANGE	HEIGHT FRAME	APPROX. WEIGHT
A-1590	24	36	5	400
A-1591*	24	32	4 3/8	355

Raised Diamond Tread. Machined Seats. Painted: Bituminous Paint.
*City of Tulare and Big Bear Standard. A1590 Conforms to East Valley Water District Standard.

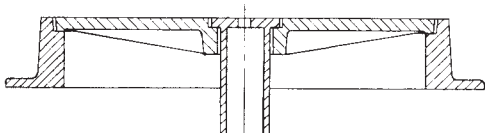
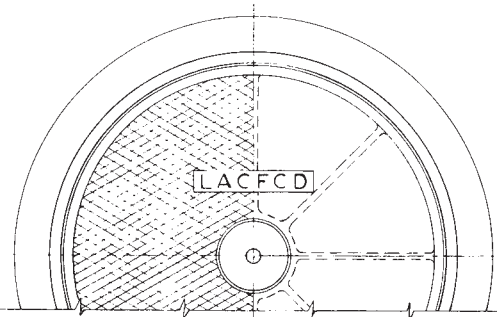

A-1220

**CAST IRON MANHOLE COVER AND FRAME
WITH 4-INCH ACCESS COVER
FOR TRAFFIC**

PLATE NUMBER	CLEAR OPENING	OVERALL FLANGE	HEIGHT FRAME	SMALL OPENING	APPROX. WEIGHT
A-1220	18	24	3	5 1/4	175
A-1221	20	26	3	5 1/4	255
A-1222	24	32	3 1/2	5 1/4	325
A-1223	30	38	6	5 1/4	600

Diamond Tread. Cover and Frame. Seats are Machined. Access Opening 4 Inches. Installed Over Valves in Traffic Area. Small Inner Cover Permits Access to Valve without Necessity of Removing Main Lid. Allows Use of Hose with Main Lid in Place. Painted: Bituminous Paint. Conforms to Los Angeles County Flood Control Standard.



**GOVERNMENT TYPE "A" INLET GRATE AND FRAME
FOR TRAFFIC**

PLATE NUMBER	CLEAR OPENING	OVERALL FLANGE	HEIGHT FRAME	APPROX. WEIGHT
A-1200	24	33½	5	455

Frame and Grate Machined to Fit. Painted: Bituminous Paint.

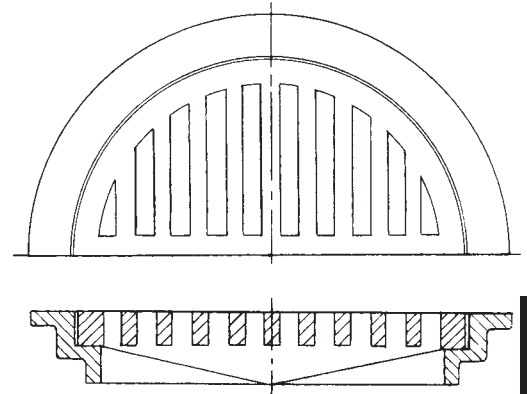

A-1200



**STANDARD CATCH BASIN GRATE AND FRAME
FOR TRAFFIC**

PLATE NUMBER	CLEAR OPENING	OVERALL FLANGE	HEIGHT FRAME	APPROX. WEIGHT
A-1210	18	26	3	170

Frame and Grate Machined to Fit. Painted: Bituminous Paint. NOTE: Solid Cover Can Be Furnished in Lieu of Open Grating.

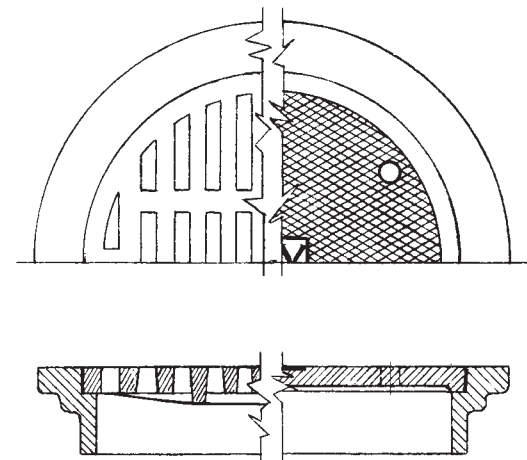

A-1210

**CAST IRON MANHOLE FRAME WITH
TIDEWATER GRATING**

PLATE NUMBER	CLEAR OPENING	OVERALL BASE	HEIGHT RING	TOTAL HEIGHT	APPROX. WEIGHT
A-1215	24	33	6	12½	375

Frame and Grate Machined to Fit. Painted: Bituminous Paint.

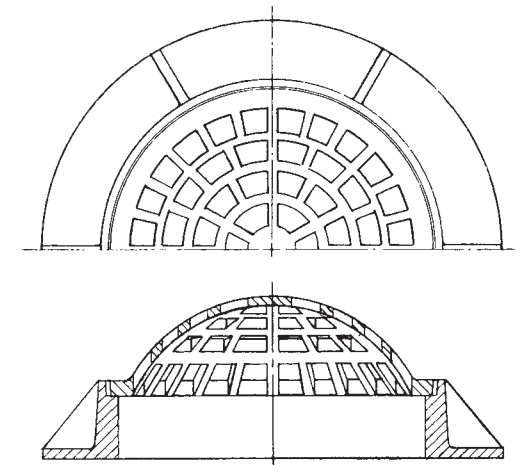

A-1215

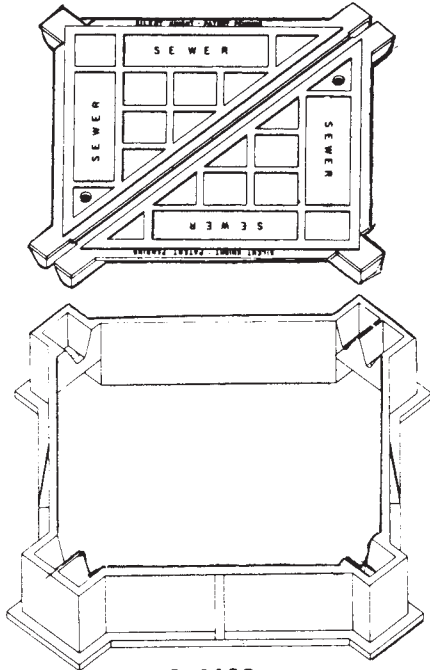

A-1190

SILENT KNIGHT MANHOLE COVER AND FRAME FOR TRAFFIC

PLATE NUMBER	CLEAR OPENING	OVERALL BASE	HEIGHT FRAME	APPROX. WEIGHT
A-1190	24 x 24	30 x 30	7	330
A-1191*	22 Dia	30 x 30	7	311
A-1193	24 x 24	28 x 28	3	235

Raising Shims Can Be Supplied for Resurfacing Roadway. Designed for 100,000 Wheel Load. Painted: Bituminous Paint.

*Designed to Take Inner Pan. A-1192

The Modern Manhole with Three Point Suspension. Non-Rocking and Rattling. Simple to Install. Raising Shims Can Be Supplied for Resurfacing Roadways. Designed for 100,000 Wheel Load. Painted: Bituminous Paint.

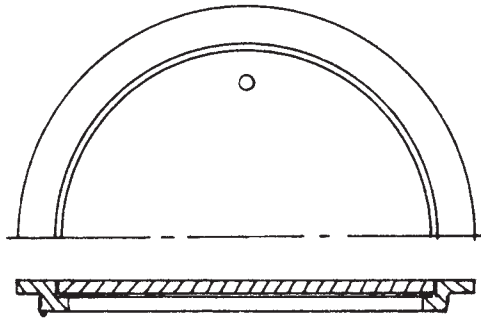

A-1300

SERIES A-1300 CISTERN OR CESSPOOL COVER AND FRAME NON-TRAFFIC

PLATE NUMBER	CLEAR OPENING	OVERALL BASE	HEIGHT FRAME	APPROX. WEIGHT
A-1301	30	36 1/2	1 1/2	203
A-1302	24	30	1 1/4	146
A-1303	18	23 1/2	1 1/4	70

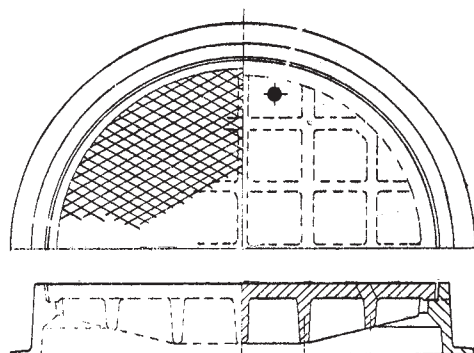

A-1148

MANHOLE COVER AND FRAME FOR AIRPORT LOADING

PLATE NUMBER	CLEAR OPENING	OVERALL BASE	HEIGHT FRAME	APPROX. WEIGHT
A-1148	36	44	6	1015

Load Rating – Exceeds 300,000 lbs. Proof Load.



**CAST IRON MANHOLE COVER AND FRAME
FOR TRAFFIC
PACIFIC NAVAL BASE TYPE**

PLATE NUMBER	NAVY DRAWING	CLEAR OPENING	OVERALL BASE	HEIGHT FRAME	APPROX. WEIGHT
A-1411	1-N-26-200	22	32	7½	340
A-1412	1-N-26-200	28	40	7	515

Conforms to Navy Department Bureau of Yards and Docks Specifications. Raised Diamond Tread. Letter Designation as Desired. Machined Seats. Painted: Bituminous Paint.

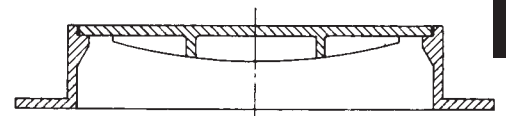
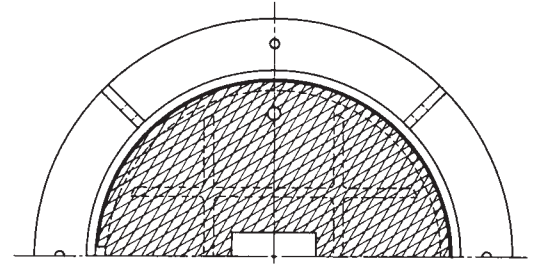

A-1410

A

**MANHOLE COVER AND FRAME
FOR TRAFFIC
U.S. TREASURY DEPARTMENT TYPE**

PLATE NUMBER	CLEAR OPENING	OVERALL FLANGE	HEIGHT FRAME	APPROX. WEIGHT
A-1140	27	38 x 38	10	630

Diamond Tread. Machined Seats. Painted: Bituminous Paint. Also Furnished with Recessed Cover for Concrete or Asphalt Fill.

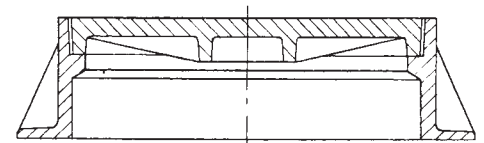
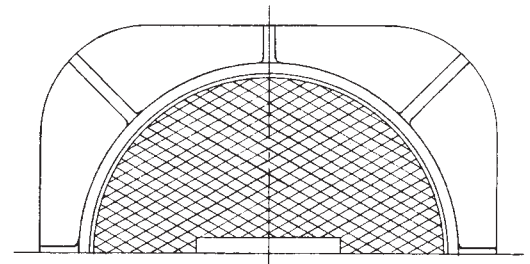

A-1140

**MANHOLE COVER AND FRAME
FOR TRAFFIC
U.S. CIVIL AERONAUTICS STANDARD**

PLATE NUMBER	CLEAR OPENING	OVERALL FLANGE	HEIGHT FRAME	APPROX. WEIGHT
A-1142	30	49 x 49	6	700
A-1143	30	51 x 51	10	970
A-1144	30	51 x 51	10	755
A-1145	30	51 x 51	10	645
A-1147	30	38 dia.	6	865

Raised Diamond Tread. Machined Seats. Painted: Bituminous Paint.

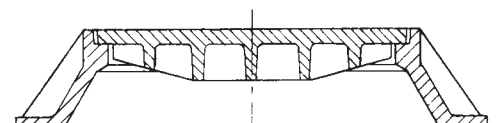
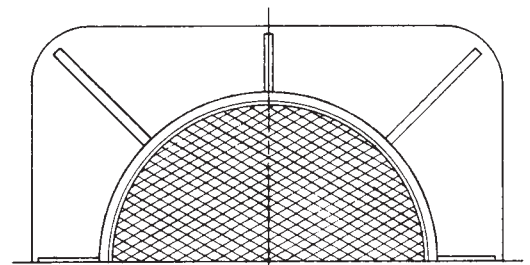

A-1142

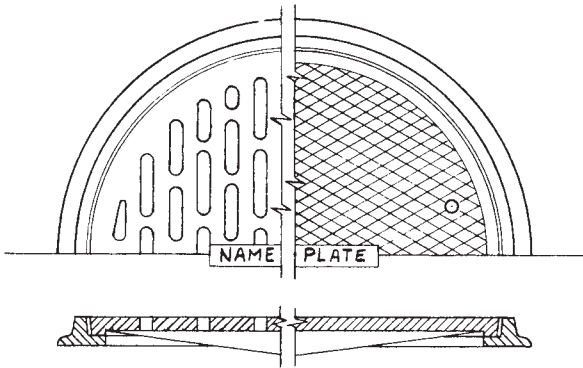

A-1530

**MANHOLE COVER AND FRAME
NON-TRAFFIC**

Conforms to City of Los Angeles B2189, State of Calif. Specs. B7-11
and Los Angeles County Flood Control 2D-156

PLATE NUMBER	CLEAR OPENING	OVERALL BASE	HEIGHT FRAME	APPROX. WEIGHT
★ A-1530	22	26	1½	130
A-1534	24	26	1½	150

NOTE: Open Grating Can Be Furnished in Lieu of Solid Cover.
For Unit with Flange Up, See Plate No. A-1535.
A-1530-B Furnished with Locking Device at Additional Cost.
A-1534 Conforms to State of California Standard U-46.

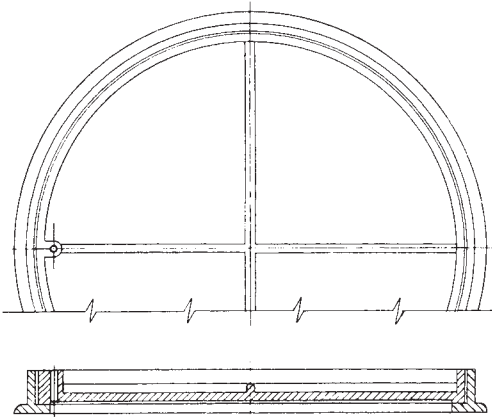

A-1533

**MANHOLE COVER AND FRAME
CONCRETE OR TERRAZZO FILLED
NON-TRAFFIC**

PLATE NUMBER	CLEAR OPENING	OVERALL FLANGE	HEIGHT FRAME	APPROX. WEIGHT
A-1533	24	28	2½	115

Machined Seats. Painted: Bituminous Paint. Conforms to City of Pomona Standard.

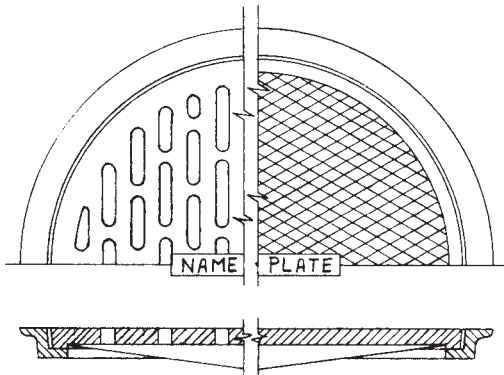

A-1535

**MANHOLE COVER AND FRAME
NON-TRAFFIC**

PLATE NUMBER	CLEAR OPENING	OVERALL FLANGE	HEIGHT FRAME	APPROX. WEIGHT	FINISH
A-1535	22	26	1½	130	Black or Galv.

Diamond Tread. Cover and Frame. Seats are Machined. Painted: Bituminous Paint or Galvanized. NOTE: Open Grating can be Furnished in Lieu of Solid Cover. See also A-1530 Series.
Can Be Bolted to Reduce Vandalism.

★ — signifies more favorable stock and volume production



**CAST IRON 36" MANHOLE COVER AND FRAME
TWO CONCENTRIC COVERS
FOR TRAFFIC**

PLATE NUMBER	CLEAR OPENING	OVERALL FRAME	HEIGHT	SMALL OPENING	APPROX. WEIGHT
A-1325	36	44	6	22	850

Conforms to San Diego Regional Drawing Number M-3. Machined Seats. Painted. Bituminous Paint.

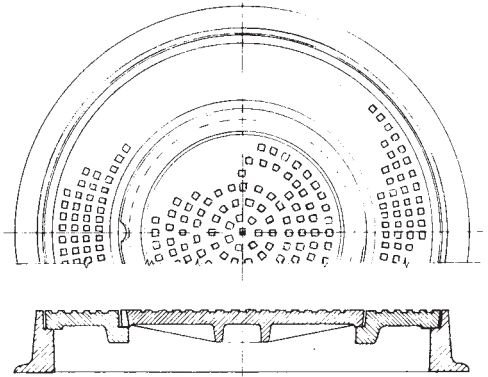

A-1325

A

**MANHOLE COVER AND FRAME
FOR TRAFFIC**

PLATE NUMBER	CLEAR OPENING	OVERALL FLANGE	HEIGHT FRAME	APPROX. WEIGHT
A-1275	22¼	35½	6	375

Square Block Tread. Cover and Frame Machined to Fit. Painted: Bituminous Paint. Conforms to City of Riverside Standard Manhole Cover and Frame.

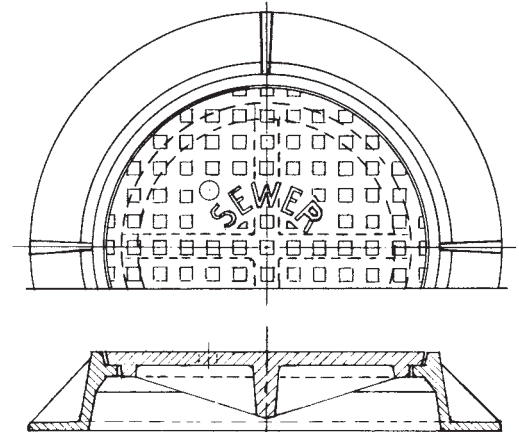

A-1275

**LOS ANGELES STANDARD
MANHOLE COVER AND FRAME
WITH INSPECTION HOLE
FOR TRAFFIC**

PLATE NUMBER	CLEAR OPENING	OVERALL RING	HEIGHT	APPROX. WEIGHT
A-1494	23¼	31¼	6	480

Conforms to City of Los Angeles Standard Drawing B-3660. Inspection Hole 5 Inch Diameter With 8 Inch Long Cap to Fit. All Seats Machined. Painted: Bituminous Paint.

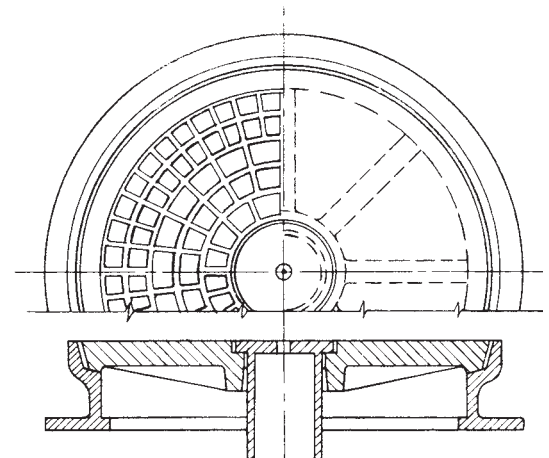

A-1494

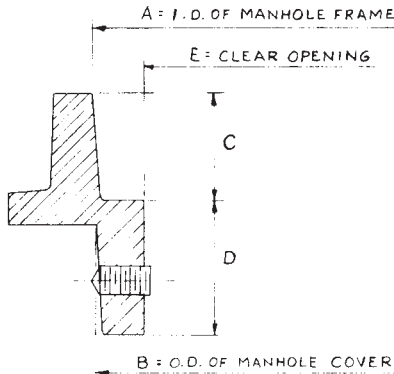
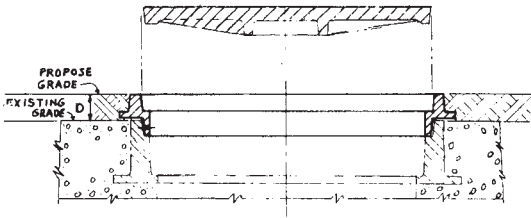

A-1180

**CAST IRON RAISING RINGS FOR MANHOLE FRAMES
PATTERN EQUIPMENT ON VARIOUS SIZES
SEATS MACHINED**

PATTERN	A	B	C	D	E
A-1030	31 ³ / ₈	31 ¹ / ₈	1	2, 3	26
A-1100	31 ³ / ₈	31 ¹ / ₈	1	2, 3	26
A-1110	30 ¹ / ₄	30	1 ¹ / ₈	2, 3	26
A-1120	32	31 ³ / ₄	2	4	30
A-1131	29	28 ³ / ₄	1 ¹ / ₂	2	27
A-1132	29	28 ³ / ₄	1 ¹ / ₂	2	27
A-1170	26	25 ³ / ₄	1 ¹ / ₂	2, 3	22 ¹ / ₂
A-1175	24	23 ³ / ₄	1 ¹ / ₂	2 ¹ / ₈ , 2 ¹ / ₂	22 ¹ / ₂
A-1254	26	25 ³ / ₄	1 ¹ / ₈	2, 3	24
A-1270	25	24 ³ / ₄	1	2, 3	23 ¹ / ₂
A-1310	24 ¹ / ₂	24 ¹ / ₄	1 ¹ / ₂	2, 3	22
A-1320	26 ¹ / ₄	26	2	3, 4	24
A-1321	29 ¹ / ₄	29	2 ¹ / ₂	3	27
A-1490	27 ³ / ₁₆	27 ¹ / ₁₆	1 ¹ / ₈	2 ¹ / ₂ , 3	23 ¹ / ₄
City of Long Beach SD-11	26	25 ³ / ₄	1 ¹ / ₂	2, 3	22 ¹ / ₄
Silent Knight	24 x 24			1 ¹ / ₈ , 1 ¹ / ₂ , 2	

When ordering, the following information must be supplied:

1. Outside diameter of present cover (Dimension "B")
2. Inside diameter of present frame (Dimension "A")
3. Thickness of present cover (Dimension "C")
4. Amount cover is to be raised (Dimension "D")
5. Alhambra Foundry identification number if available.

**HEAVY DUTY FRAME AND COVER
WITH ROUND ACCESS COVER**

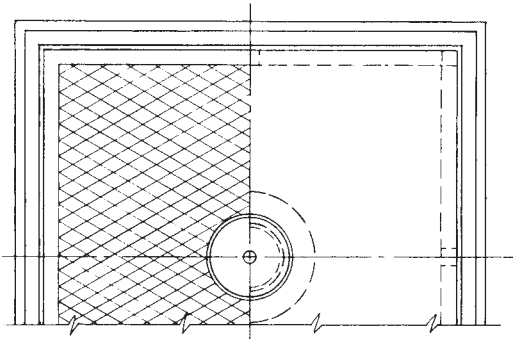

A-2005

PLATE NUMBER	CLEAR OPENING	OVERALL FLANGE	HEIGHT FRAME	APPROX. WEIGHT
A-2005*	24 x 24	29 ¹ / ₂ x 29 ¹ / ₂	2 ¹ / ₂	395

Access Opening 4 Inches. Diamond Tread Cover. Painted: Bituminous Paint.
*Conforms to Forest Lawn Standards.

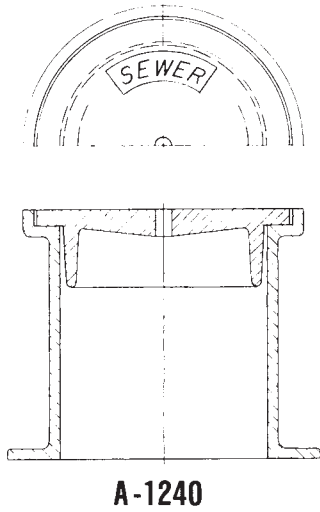

**TRAFFIC
LAMPHOLE COVER AND FRAME
FOR SEWER LINE INSPECTION AND EXAMINATION**

PLATE NUMBER	CLEAR OPENING	OVERALL BASE	HEIGHT FRAME	APPROX. WEIGHT
★A-1240	10	15	12	120
★A-1241*	11½	17	12	135

Painted: Bituminous Paint.
*Conforms to City of Los Angeles S-164-0.

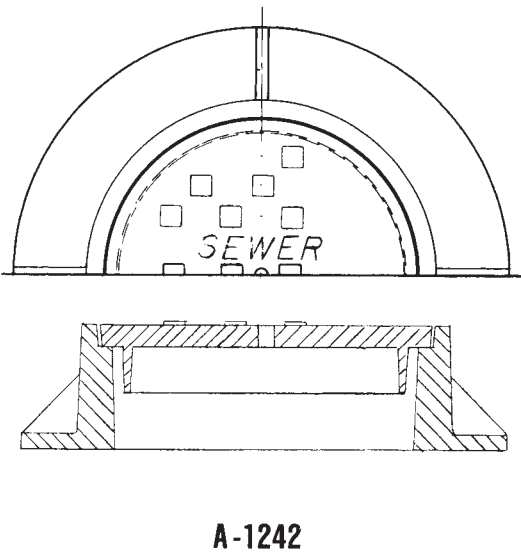

**TRAFFIC
MONUMENT MARKER HANDHOLE COVER
AND FRAME
STATE OF CALIFORNIA STANDARD**

PLATE NUMBER	CLEAR OPENING	OVERALL BASE	HEIGHT FRAME	APPROX. WEIGHT
★A-1242	10	16	4	68
★A-1243*	10	16	4	68
A-1244	14	18	8	135

*Cover Marked ESBCWD
Painted: Bituminous Paint.

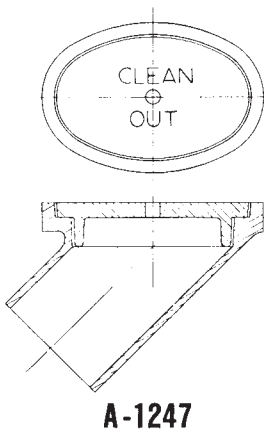

**TRAFFIC
ANGLE CLEANOUT COVER AND FRAME**

PLATE NUMBER	CLEAR OPENING	OVERALL TOP	OVERALL HEIGHT	APPROX. WEIGHT
★A-1247	9½	12 x 16	12¼	85

Conforms to City of Seal Beach Standard. Painted: Bituminous Paint.

★ — signifies more favorable stock and volume production



**TRAFFIC
MONUMENT HANDHOLE COVER AND FRAME**

PLATE NUMBER	CLEAR OPENING	DIAMETER TOP	HEIGHT FRAME	APPROX. WEIGHT
A-2920	3¾	7½	12	43

Painted: Bituminous Paint.

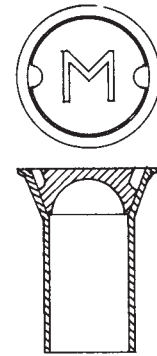

A-2920

A

**TRAFFIC
TEST STATION MARKER COVER AND FRAME**

PLATE NUMBER	CLEAR OPENING	OVERALL BASE	HEIGHT FRAME	APPROX. WEIGHT
A-2922	6¾	15½ x 15½	9	80

Painted: Bituminous Paint.

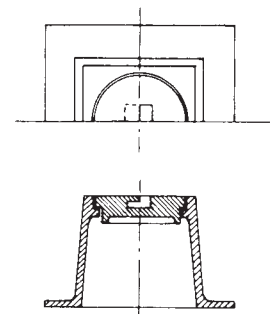

A-2922

**TRAFFIC
MONUMENT HANDHOLE COVER AND FRAME**

PLATE NUMBER	CLEAR OPENING	OVERALL TOP	HEIGHT FRAME	APPROX. WEIGHT
★A-2925	8	10¾	6	52

Conforms to Orange County Standard Plan #405, With Special Lettering. Painted: Bituminous Paint.

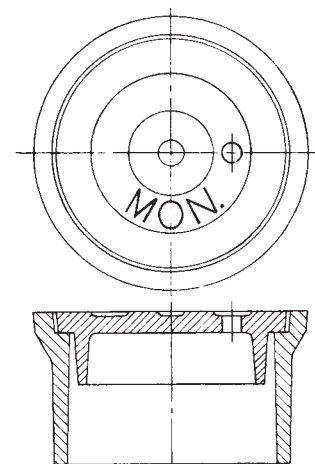

A-2925

★ — signifies more favorable stock and volume production

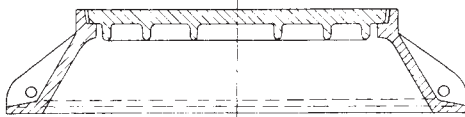
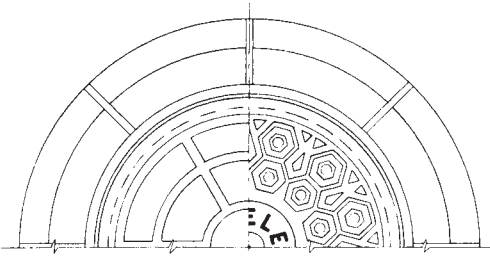

A-1130

**MANHOLE COVER AND FRAME
TELEPHONE COMPANY TYPE — FOR TRAFFIC**

PLATE NUMBER	CLEAR OPENING	OVERALL FLANGE	HEIGHT	APPROX. WEIGHT
A-1131	27 Dia.	46½ Dia.	10	630
A-1132	27 Dia.	46½ Dia.	6	600
A-1133	30 Dia.	49 Dia.	10	730
A-1134	30 Dia.	49 Dia.	6	610

Special Tread. Machined Fit. Bell System type is Shown.
Suffix letter G to above numbers designates General Telephone requirements.

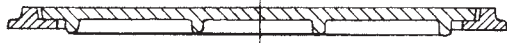
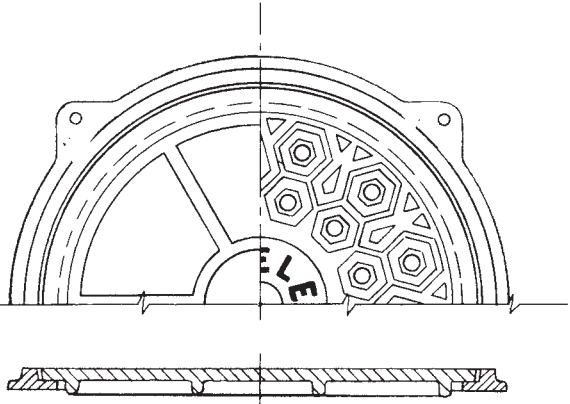

A-1135

**MANHOLE COVER AND FRAME
TELEPHONE COMPANY TYPE — NON-TRAFFIC**

PLATE NUMBER	CLEAR OPENING	OVERALL FLANGE	HEIGHT	APPROX. WEIGHT
A-1135	27	32	1½	225
A-1136	30	35	1½	260

Special Tread. Machined Fit. Bell System type is Shown.
Suffix letter G to above numbers designates General Telephone requirements.

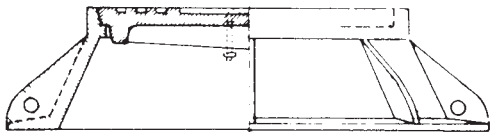
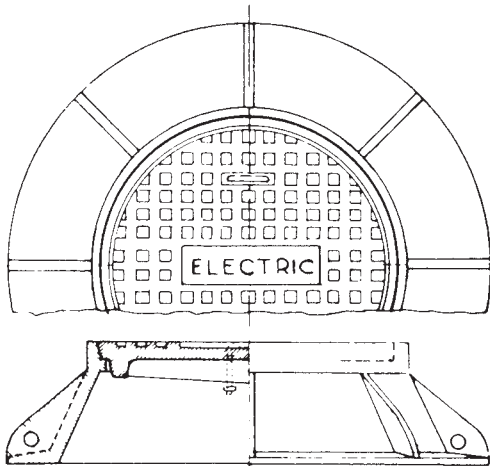

A-1120

**MANHOLE COVER AND FRAME
ELECTRIC OR TELEPHONE — FOR TRAFFIC**

PLATE NUMBER	CLEAR OPENING	OVERALL FLANGE	HEIGHT	APPROX. WEIGHT
A-1120	30 Dia.	49 Dia.	10	900
A-1121	30 Dia.	49 Dia.	6	885

Special Tread. Machined Fit.



**CAST IRON COVER, FRAME AND INNER PAN
FOR TRAFFIC**
For Electric Installations.
Inner Pan made with Caulking Joint

PLATE NUMBER	CLEAR OPENING	OVERALL FLANGE	HEIGHT	APPROX. WEIGHT
A-25838	30	40	5	660

Radial Block Tread. Lift Ring. Cover and Frame Machined to Fit.

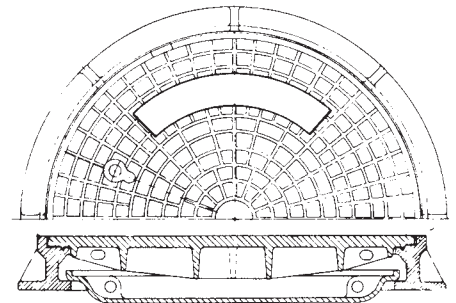

A-25838

A

**CAST IRON COVER AND FRAME
FOR TRAFFIC**

For Electrical Installation
Fitted with Neoprene Gaskets and Bolted Down with
4— $\frac{5}{8}$ " Stainless Steel Cap Screws.
Designed for use in Precast Concrete Vault Structures.

PLATE NUMBER	CLEAR OPENING	OVERALL FLANGE	HEIGHT	APPROX. WEIGHT
A-1105	27	32 $\frac{1}{2}$	2	300
A-1106	30	35 $\frac{7}{8}$	2	380
A-1108	36	42	2	500

Radial Block Tread. Lift Holes. Cover and Frame Machined to Fit. Conforms to Southern California Edison Drawing UGS 062.

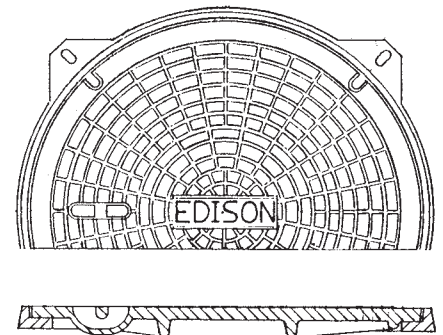

A-1105

**SPLICE BOX COVER AND FRAME
NON-TRAFFIC**

PLATE NUMBER	CLEAR OPENING	OVERALL BASE	HEIGHT FRAME	APPROX. WEIGHT
A-1690	18 x 36	23 x 41	2 $\frac{1}{8}$	225

Diamond Tread. Cover and Frame Carefully Fitted. Pick Hole Lift. Painted: Bituminous Paint. Conforms to Bell Telephone Drawing CS-1475. Covers Marked Bell System, Telephone or Electric.

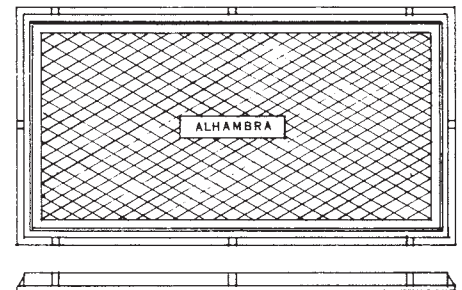

A-1690

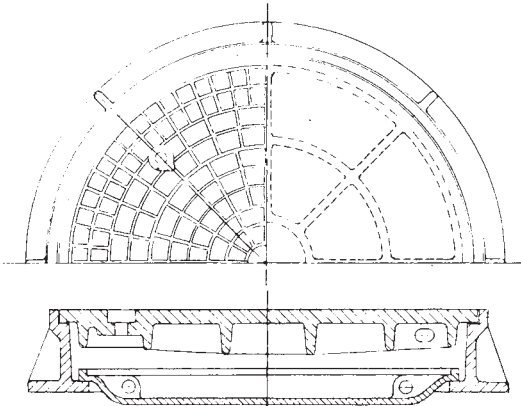

A-1070

**CAST IRON COVER, FRAME AND INNER PAN
FOR TRAFFIC**

For Electrical Installations. Cast Steel Covers furnished on Specification. From L.A. Bureau of Power and Light Designs. Inner Pan made with Caulking Joint.

PLATE NUMBER	CLEAR OPENING	OVERALL FLANGE	HEIGHT	APPROX. WEIGHT
A-1071	26 Dia.	38 Dia.	5	670
A-1072	28 Dia.	40 Dia.	5	675
A-1073	30 Dia.	40 Dia.	7	810
A-1074	36 Dia.	44 Dia.	5	850

Radial Block Tread. Lift Holes. Cover and Frame Machined to Fit. Painted: Bituminous Paint.

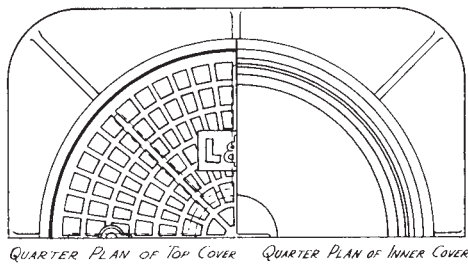

QUARTER PLAN OF TOP COVER QUARTER PLAN OF INNER COVER

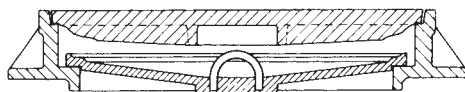

A-1100

**CAST IRON COVER, FRAME AND INNER PAN
SOUTHERN CALIFORNIA EDISON CO. TYPE**

For Electrical Installations.
Inner Pan made with Caulking Joint.
FOR TRAFFIC

PLATE NUMBER	CLEAR OPENING	OVERALL FLANGE	HEIGHT	APPROX. WEIGHT
A-1100	26	38 1/2 x 38 1/2	6	725

**CAST IRON COVER, FRAME AND INNER PAN
SOUTHERN CALIFORNIA EDISON CO. TYPE
NON-TRAFFIC**

Inner Pan made with Caulking Joint.

PLATE NUMBER	CLEAR OPENING	OVERALL FLANGE	HEIGHT	APPROX. WEIGHT
A-1110	26 Dia.	35 Dia.	6	415

Radial Block Tread. Lift Holes. Cover and Frame Machine Fit. Inner Pan with Caulking Joint.

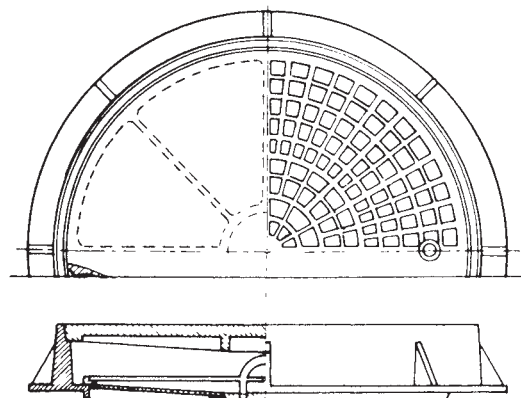

A-1110



**CAST IRON VAULT MANHOLE COVER,
FRAME AND INNER PAN
FOR TRAFFIC
TWO CONCENTRIC COVERS**

PLATE NUMBER	CLEAR OPENING	OVERALL FLANGE	HEIGHT	SMALL OPENING	APPROX. WEIGHT
A-1075	30	40	7	22	800

Raised Block Tread Lift Holes. Cover and Frame Machined to Fit. Painted: Bituminous Paint.

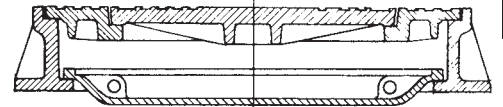
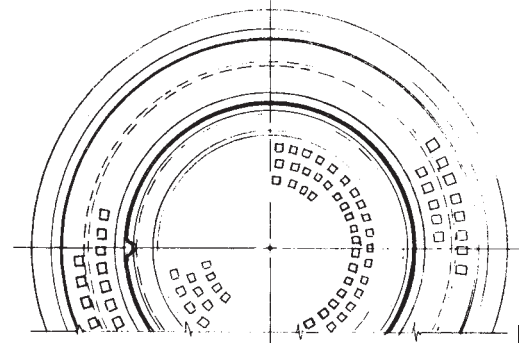

A-1075

A

**CAST IRON VAULT OR LARGE MANHOLE COVER
FOR TRAFFIC
TWO CONCENTRIC COVERS**

PLATE NUMBER	CLEAR OPENING	OVERALL FLANGE	HEIGHT	SMALL OPENING	APPROX. WEIGHT
A-1323	42	58	10	24	1,480
A-1324	42	58	4	24	1,075

Conforms to San Diego Gas & Electric Company Drawing No. B-5384 Page C-95.2. Navy Drawing F-10-5-S29 Electric Vault Manhole and City of San Diego. Square Block Tread. Machined Seats. Painted: Bituminous Paint. NOTE: For 36" Opening See A-1325 Page A-13

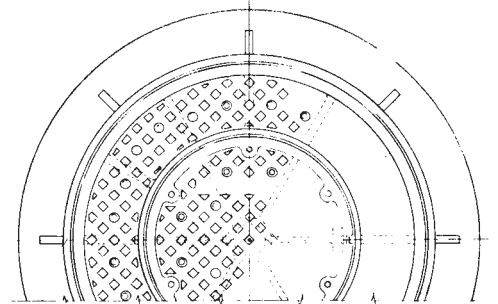

A-1323

**MANHOLE COVER AND FRAME
FOR TRAFFIC
TWO CONCENTRIC COVERS**

PLATE NUMBER	CLEAR OPENING	OVERALL FLANGE	HEIGHT	SMALL OPENING	APPROX. WEIGHT
A-1514	44	53	7 1/4	24	1,025

Conforms to the City of Los Angeles Department of Water & Power Drawing No. C-626-R4. Raised Tread. Cover and Frame Machined to Fit.

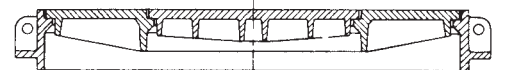
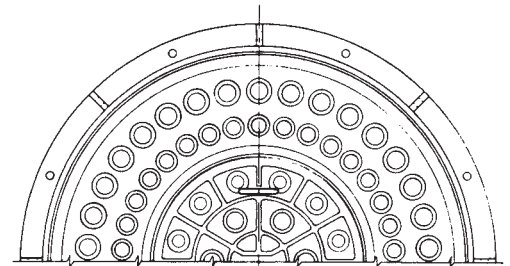

A-1514



"WATERTIGHT" CAST IRON MANHOLE COVER AND FRAME FOR TRAFFIC WITH TWO CONCENTRIC WATERTIGHT COVERS

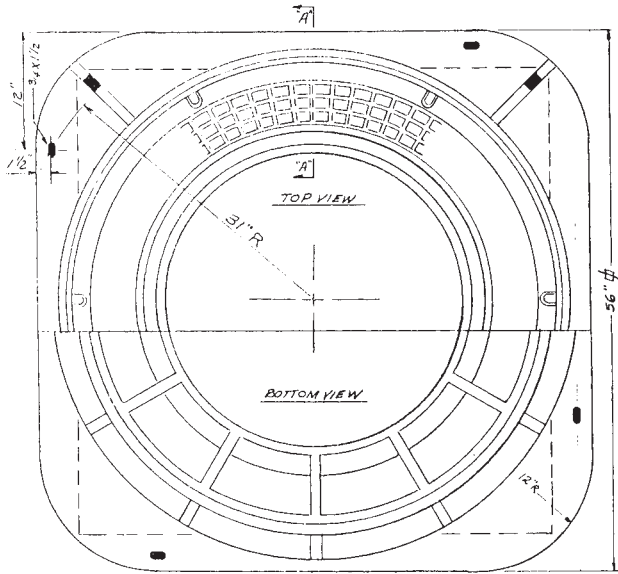

A-1517

PLATE NUMBER	CLEAR OPENING	OVERALL FLANGE	HEIGHT	SMALL OPENING	APPROX. WEIGHT
A-1517	48	56 x 56	5 1/2	30	1500

Designed for Large Vault Openings Requiring Watertight Applications. Assembly Supplied with A-1106 as Inner Cover. See Page A-19 for A-1106 Specifications. Covers Supplied with Radial Block Tread, Bolts, and (2) Gaskets. Covers and Frame Machined to Fit.

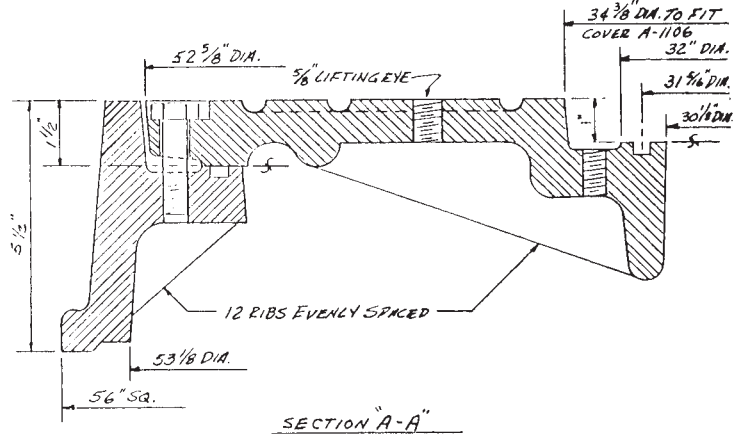

CAST IRON VAULT OR LARGE MANHOLE COVER AND FRAME FOR TRAFFIC WITH TWO CONCENTRIC COVERS

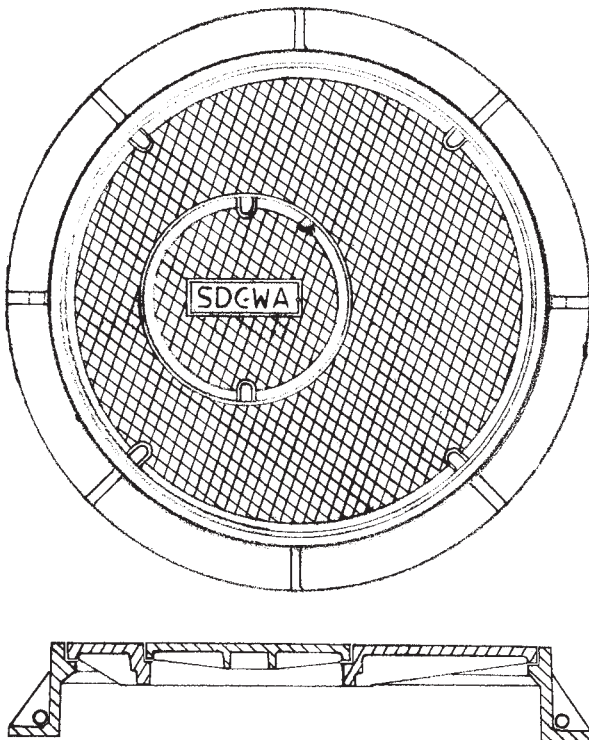

A-1518

PLATE NUMBER	CLEAR OPENING	OVERALL FLANGE	HEIGHT	SMALL OPENING	APPROX. WEIGHT
A-1518	48	62	10	20	1414

Frame and Covers Machined to Fit.
Conforms to San Diego County Water Authority Plan SD-21.



**CAST IRON COVER AND FRAME
FOR TRAFFIC**

PLATE NUMBER	CLEAR OPENING	OVERALL BASE	HEIGHT	APPROX. WEIGHT
A-1076	35	47	9¾	840

Conforms to San Diego Gas & Electric Standard Drawing No. B-5383 Page C-95.1. Cover and Frame Machined to Fit. Non-Skid Checkered Cover with Holes in Center. Painted: Bituminous Paint.

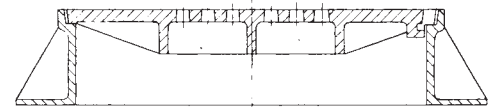
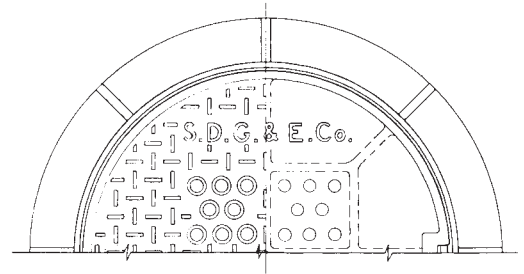

A-1076

A

**CAST IRON VAULT OR LARGE MANHOLE
COVER AND FRAME
FOR TRAFFIC
TWO CONCENTRIC COVERS**

PLATE NUMBER	CLEAR OPENING	OVERALL FLANGE	HEIGHT	APPROX. WEIGHT
A-1513	42	56	10	1,200

Conforms to Navy Plate No. 12—Pattern No. 3 Electric Vault Manhole. Square Block Tread. Machined Cover Seats. Painted: Bituminous Paint. Net Opening of Inside Cover 24".

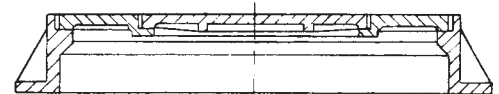
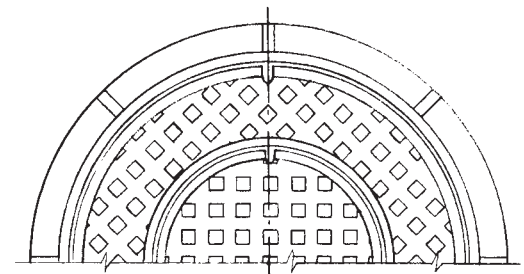

A-1513

**CAST IRON VAULT OR LARGE MANHOLE
COVER AND FRAME
FOR TRAFFIC
TWO CONCENTRIC COVERS**

PLATE NUMBER	CLEAR OPENING	OVERALL BASE	HEIGHT	APPROX. WEIGHT
A-1515	48	62	10	1,800
A-1516	48	58	4½	1,500

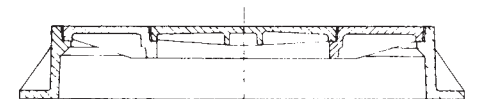
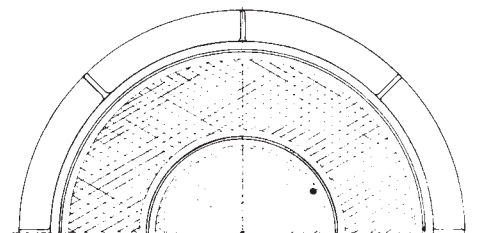

A-1515

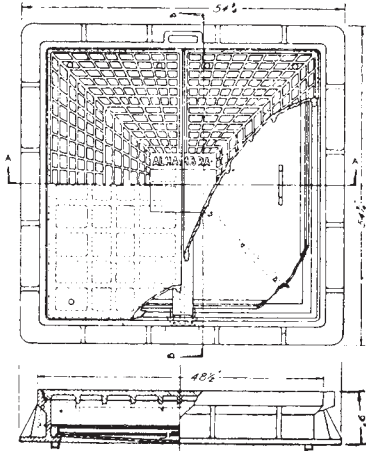

A-1001

**CAST IRON VAULT COVER AND FRAME
FOR TRAFFIC
EDISON TYPE
Split Cover and Steel Inner Pan**

PLATE NUMBER	CLEAR OPENING	OVERALL BASE	HEIGHT	APPROX. WEIGHT
A-1001	48 x 48	62 x 62	9 1/2	2,339
A-1002	41 x 41	55 x 55	9	1,900
A-1003	34 x 34	47 x 47	8	1,200
A-1004	33 x 33	47 x 47	9	1,400

Square Block Tread. Drop Lift Handles. Seats of Cover and Frame carefully ground.

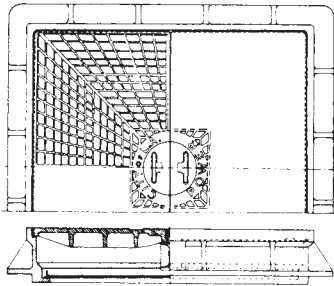

A-1010

**EXTRA HEAVY VAULT COVER AND FRAME
FOR TRAFFIC
LOS ANGELES CITY TYPE
Conforms to Department Water & Power Dwg. A-348 Cast Iron.
Split Cover, Cast Iron Frame and Steel Inner Pan.**

PLATE NUMBER	CLEAR OPENING	OVERALL BASE	HEIGHT	APPROX. WEIGHT
A-1010	40 x 40	55 x 55	9 1/4	1,650

Square Block Tread. Drop Lift Handles. Seats of Cover, Frame and Pocket Fully Machined. Galvanized Pan and Cover Support Beam.

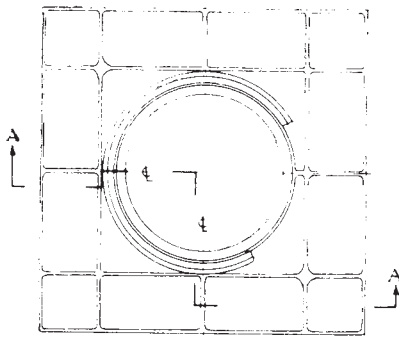

PLAN



A-1030

**CAST IRON FRAMELESS COVERS
FOR TRAFFIC
EDISON TYPE**

PLATE NUMBER	CLEAR OPENING	OVERALL BASE	HEIGHT	APPROX. WEIGHT
A-1030	48 x 48	54 x 54	6	1,575
A-1031	54 x 96	60 x 102	6	2,265

Center Cover—26" Clear Opening. Seal Pan Machined to Fit.



VAULT COVER AND FRAME
NON-TRAFFIC
EDISON COMPANY TYPE
Two-Piece Cover. Steel Inner Pan.

PLATE NUMBER	CLEAR OPENING	OVERALL BASE	HEIGHT FRAME	APPROX. WEIGHT
A-1050	34 x 34	44 x 44	6 1/4	947

Square Block Tread. Pick Hole Lifts. Seats of Cover and Frame Ground to Fit.

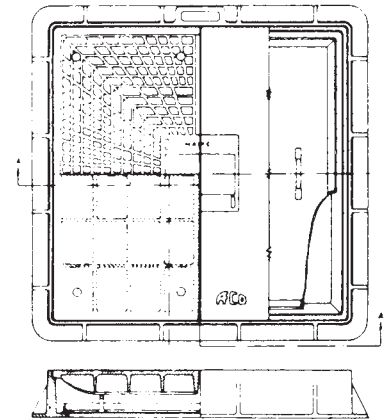

A-1050



FABRICATED STEEL COVER, FRAME
AND INNER COVER
NON-TRAFFIC
CHECKERED PLATE TREAD

PLATE NUMBER	CLEAR OPENING	OVERALL OF TOP	HEIGHT	APPROX. WEIGHT
A-1055	41 x 41	47 1/2 x 47 1/2	3 1/4	390

Painted: Shop Coat Primer.

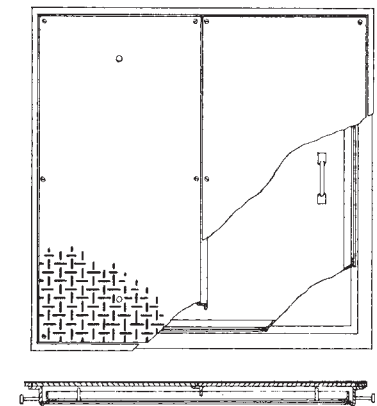

A-1055

SHALLOW TYPE VAULT COVER AND FRAME
FOR TRAFFIC

For Usage where Head Room is Limited or Thin Concrete Slabs.

PLATE NUMBER	CLEAR OPENING	OVERALL BASE	HEIGHT FRAME	APPROX. WEIGHT
A-1060	41 1/2 x 41 1/2	53 x 53	4	1,300

Square Block Tread. Drop Lift Handles. Seat and Cover Ground to Fit. Painted: Bituminous Paint.

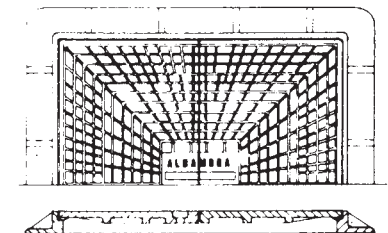

A-1060

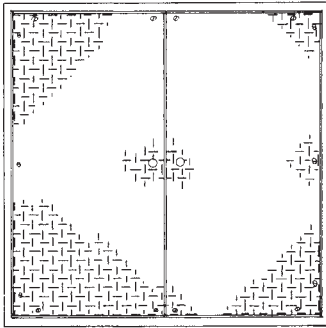

A-1080

FABRICATED STEEL CHECKERED PLATE COVER AND FRAME

PLATE NUMBER	STRENGTH	CLEAR OPENING	OVERALL OF TOP	HEIGHT	APPROX. WEIGHT
A-1080	Non-Traffic	40 x 40	44 1/2 x 44 1/2	2 1/4	210
A-1081	Traffic	40 x 40	46 x 46	3	380
A-1082	Non-Traffic	48 x 48	52 x 52	2 1/4	297
A-1083	Traffic	48 x 48	54 x 54	3	537

Painted: Shop Coat Primer.

NOTE: Special Sizes can be Fabricated Upon Request.

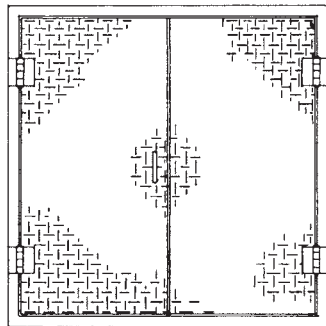

A-1084

FABRICATED STEEL CHECKERED PLATE HINGED COVER AND FRAME

PLATE NUMBER	STRENGTH	CLEAR OPENING	OVERALL OF TOP	HEIGHT	APPROX. WEIGHT
A-1084	Non-Traffic	36 x 36	41 x 41	2 1/2	320
A-1085	Non-Traffic	48 x 48	53 x 53	2 1/2	510

Conforms to Plate No. 4—Navy Specification 42Ya. Painted: Shop Coat Primer.

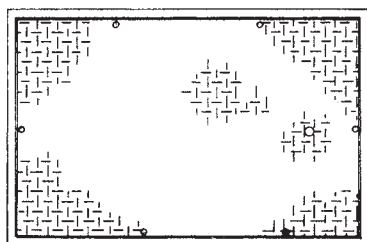

A-1086

FABRICATED STEEL CHECKERED PLATE PULL BOX COVER AND FRAME

PLATE NUMBER	STRENGTH	CLEAR OPENING	OVERALL OF TOP	HEIGHT	APPROX. WEIGHT
A-1086*	Non-Traffic	24 x 36	28 x 40	2 1/4	120
A-1087	Traffic	24 x 36	29 x 41	2 3/8	175
A-1088*	Non-Traffic	30 x 48	36 x 54	2 7/8	250
A-1089	Traffic	30 x 48	36 x 54	3	330
A-1090	Non-Traffic	36 x 36	40 x 40	2 1/4	200
A-1091	Traffic	36 x 36	40 x 40	2 3/8	265
A-1092*	Non-Traffic	24 x 42	30 x 48	2 1/4	175
A-1093	Traffic	24 x 42	30 x 48	2 3/8	225

*Conforms to City of Los Angeles Dept. of Water and Power Drawing ES-69. Painted: Shop Coat Primer.

NOTE: Fabricated Assemblies Can Be Modified for Watertight Conditions.

SECTION

B



B

**MANHOLE
and
VAULT
HARDWARE**

Catch Basin - Electrical Underground

Manhole and Catch Basin Steps

Curb Armor

Vault M.H. Ladders

Support Bolts and Protection Bar

Ventilator Grates and Frames

Conduit Adaptors



STEP FOR CONCRETE STRUCTURES

PLATE NUMBER	WIDTH	DEPTH	APPROXIMATE WEIGHT	SIZE	FINISH
★ A-3321	14	3¼	5	¾Ø	Galv.

Conforms to A.P.W.A. Std. Plan 635-0, Type 2.

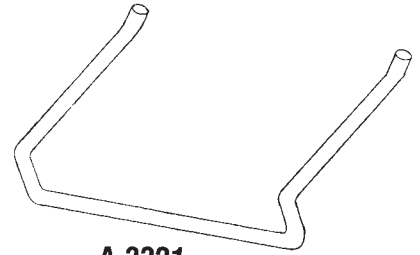

A-3321

STANDARD DROP INLET STEP

PLATE NUMBER	WIDTH	DEPTH	APPROXIMATE WEIGHT	SIZE	FINISH
★ A-3320	14	10	5	¾Ø	Galv.

Conforms to Edison Co. and State and various City and County Standards.

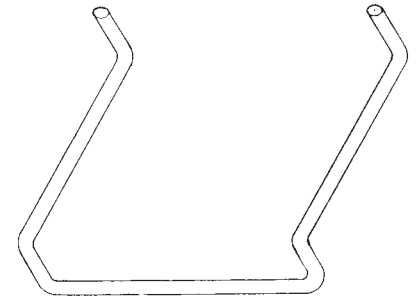

A-3320

B

STEP FOR ROUND MANHOLE

PLATE NUMBER	WIDTH	DEPTH	APPROXIMATE WEIGHT	SIZE	FINISH
★ A-3316	14	12	6	¾Ø	Galv.

Conforms to Los Angeles County Engineer Std. Dwg. S-17, City of Los Angeles Std. Dwg. DL-2459.

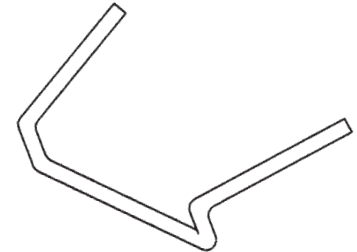

A-3316

STEP FOR CONCRETE STRUCTURES

PLATE NUMBER	WIDTH	DEPTH	APPROXIMATE WEIGHT	SIZE	FINISH
★ A-3309	14	10	4½	¾Ø	Galv.

Conforms to Los Angeles Flood Control Std. Dwg. 2D96.

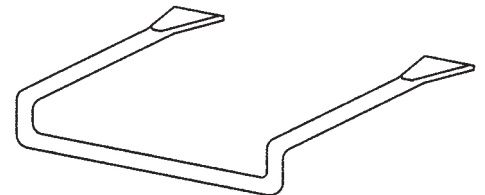

A-3309

STEP FOR CONCRETE STRUCTURES

PLATE NUMBER	WIDTH	DEPTH	APPROXIMATE WEIGHT	SIZE	FINISH
★ A-3308	14	10	5	¾Ø	Galv.

Conforms to Los Angeles Flood Control Std. Dwg 2D96.

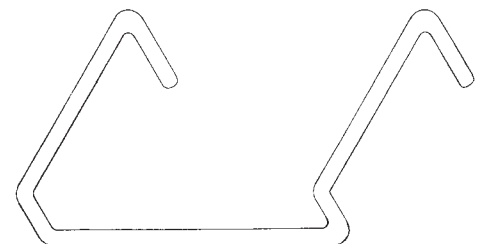

A-3308

★ — signifies more favorable stock and volume production

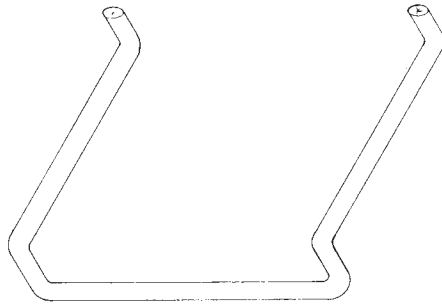

A-3325

STEP FOR CONCRETE STRUCTURES

PLATE NUMBER	WIDTH	DEPTH	APPROXIMATE WEIGHT	SIZE	FINISH
★A-3325	16	13	12	10	Galv.

Conforms to O.S.H.A. Standards.

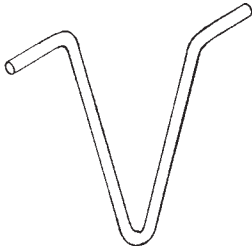

A-3350

PULLING-IN IRONS FOR ELECTRICAL VAULTS

PLATE NUMBER	WIDTH	DEPTH	APPROXIMATE WEIGHT	SIZE	FINISH
★A-3350	8¾	9	4¾	7/80	Galv.

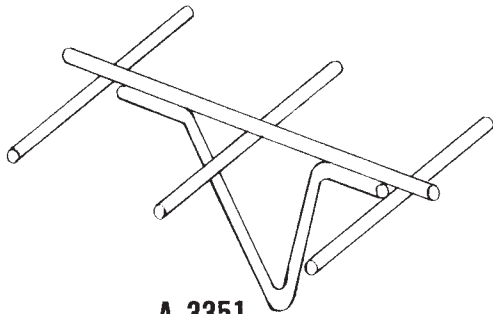

A-3351

**PULLING-IN IRONS FOR ELECTRICAL VAULTS
GENERAL TELEPHONE STD.**

PLATE NUMBER	WIDTH	DEPTH	APPROXIMATE WEIGHT	SIZE	FINISH
A-3351	24 x 14	12	10	7/80	Galv.

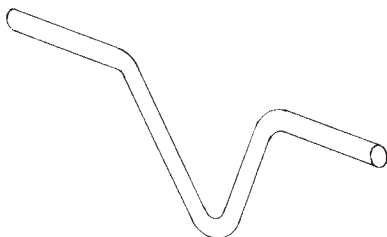

A-3352

**LIFT IRON
GENERAL TELEPHONE STD.**

PLATE NUMBER	LENGTH	DEPTH	APPROXIMATE WEIGHT	SIZE	FINISH
A-3352	12	5	1.5	5/80	Galv.

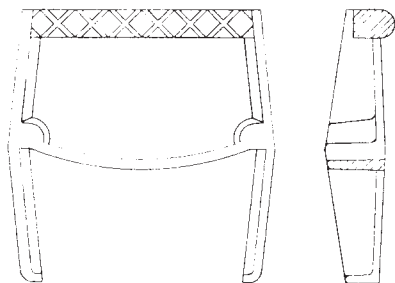

A-3340

**CAST IRON STEP FOR ROUND OR
RECTANGULAR STRUCTURES**

PLATE NUMBER	WIDTH	DEPTH	APPROXIMATE WEIGHT	FINISH
A-3340	8¾	10	10½	Painted
A-3341	10	9	11	Painted
A-3342*	14	11½	20	Painted

Cast Iron Manhole Steps are Adaptable to Any Construction. More Permanent as They Resist Rust and Corrosion. Black Steps Painted Bituminous Paint. Galvanized also Available on Request.

*Conform to Fig. 19 Federal Specs.

★ — signifies more favorable stock and volume production



GALVANIZED LADDERS AND SUPPORTS

A-3380 VAULT LADDER

Galvanized Steel Ladder 12'' Wide with 5/8''Ø Steel Rebar Rungs. Stringers Bent to Hang From A-3383 Support Bar. Specify Length Required When Ordering.

A-3382 VAULT LADDER

Galvanized Steel Ladder 12'' Wide with 5/8''Ø Rungs. Stringers Bent to Hang From A-3383 Support Bar.

A-3383 GALVANIZED SUPPORT BAR

PLATE NUMBER	WIDTH	DEPTH	APPROXIMATE WEIGHT	SIZE	FINISH
A-3383	15	12	6	3/4''Ø	Galv.

A-3400 GALVANIZED STEEL LADDER

With Angle Clip Connections. Channel Stringers on 14'' Spread with 5/8''Ø Steel Rebar Rungs. Wall Brackets Can Be Used in Lieu of Angle Clips.

A-3885 NAVAL P.W.O.

16'' Galvanized Steel Ladder with Adjustable Swing Joint Connections. 3/8'' x 2 1/2'' Stringers with 3/4''Ø Rungs.

NOTE: Ladders Meeting O.S.H.A. Standards Can Be Made on Request.
Wall Brackets Available for Use on All Ladders.

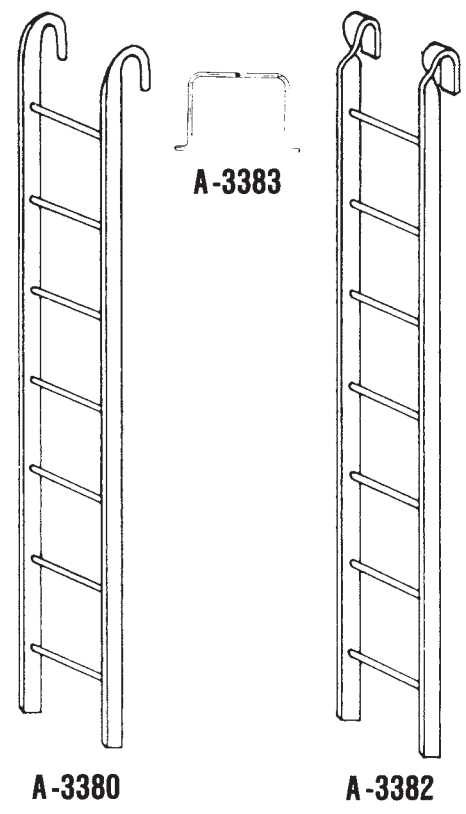

A-3380

A-3382

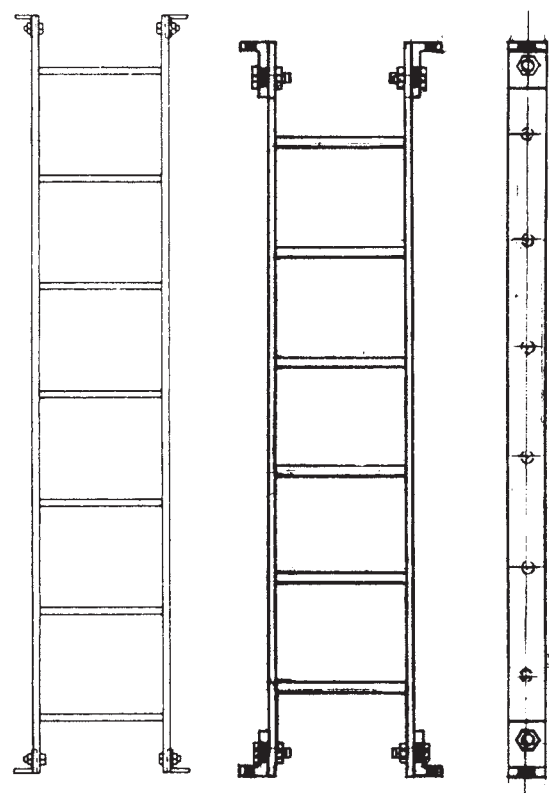

A-3400

A-3885

B

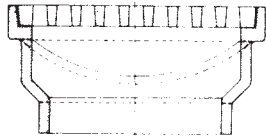
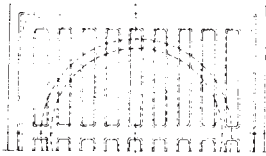

A-2120

**VENTILATOR GRATE AND FRAME
FOR UNDERGROUND ELECTRICAL VAULTS
AND MANHOLES
RECTANGULAR
NON-TRAFFIC**

PLATE NUMBER	PIPE SIZE	OVERALL TOP	APPROX. WEIGHT
A-2121	8	12 x 12	50
A-2122	6	9 x 9	30

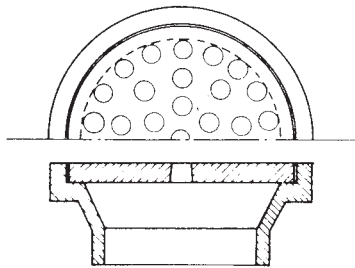

A-2130

**VENTILATOR GRATE AND FRAME
FOR UNDERGROUND ELECTRICAL VAULTS
AND MANHOLES
ROUND
FOR TRAFFIC**

PLATE NUMBER	PIPE SIZE	DIAMETER TOP	APPROX. WEIGHT
★A-2130	8	10½	40

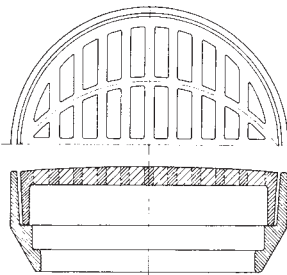

A-2140

**VENTILATOR GRATE AND FRAME
FOR UNDERGROUND ELECTRICAL VAULTS
AND MANHOLES
ROUND
NON-TRAFFIC**

PLATE NUMBER	PIPE SIZE	DIAMETER TOP	APPROX. WEIGHT
★A-2140	8	11¼	30

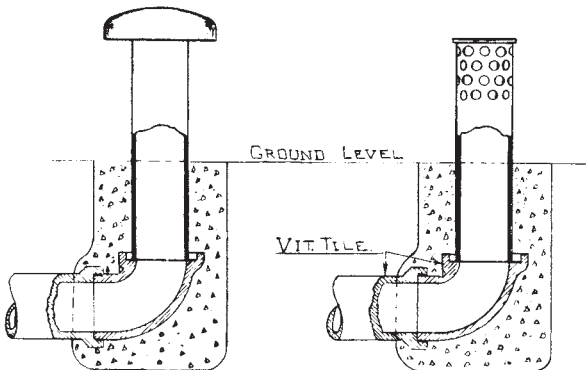

A-2160

A-2150

**PIPE VENTS
PARTICULARLY SUITED FOR UNDERGROUND TRANSFORMER VAULTS**

PLATE NUMBER	DIAMETER PIPE	LENGTH	APPROX. WEIGHT
A-2151	4	42	38
★A-2153	6	42	67
★A-2155	8	42	80
A-2157	10	42	98
A-2159	12	42	118
A-2161	4	42	40
A-2163	6	42	70
A-2165	8	42	84
A-2167	10	42	105
A-2169	12	42	124

Any Size or Length Made to Order. Furnished with Mushroom Type Hood or Drilled Holes. Type with Holes Furnished with Welded Cap Unless Otherwise Specified. Painted or Galvanized.

★ — signifies more favorable stock and volume production



**CURB ANGLES
FOR CATCH BASIN INLETS**

PLATE NUMBER	SIZE ANGLE	APPROX. WEIGHT
★ A-3900	2½ x 2½ x ¾	5# per ft.
A-3901	2½ x 2½ x ¼	4.5# per ft.
A-3902	3½ x 3½ x ⅝	8# per ft.
A-3903	3½ x 3½ x ¾	9.5# per ft.
A-3904	3½ x 3½ x 1½	12# per ft.
A-3905	4 x 4 x ½	14# per ft.

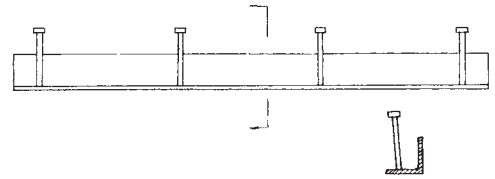

A-3901

Furnished with Welded Anchors and Holes for Support Bolts, See Page B-6.

Furnished with Welded Anchors and Holes for Support Bolts. See Page B-6.

★Signifies More Favorable Stock and Volume Production.

**FORMED STEEL FACE PLATE
FOR CATCH BASIN INLETS
Plate No. A-3911, Approximate Weight 12 lbs. per Foot.
For 4½" thick slab.**

Conforms to City of Los Angeles Std. Plan #B-3651 and Various Other City and County Agencies.

Furnished with Welded Anchors and Holes for Support Bolts. See Page B-6.

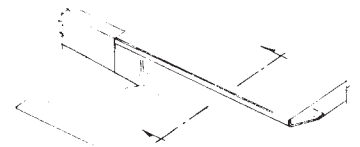

B

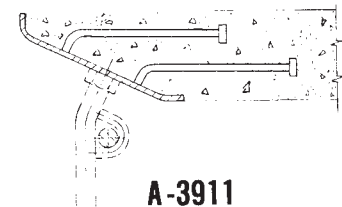

A-3911

**FORMED STEEL FACE PLATE
FOR CATCH BASIN INLETS
Plate No. A-3912, Approximate Weight 15 lbs. per Foot.
For 6" thick slab.**

Conforms to Clark Co. Uniform Standard Drawing 418.

Furnished with Anchors and Holes for Support Bolts. See Page B-6.

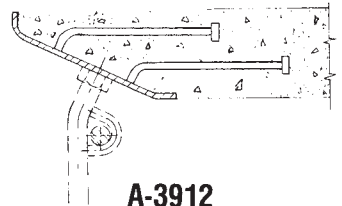
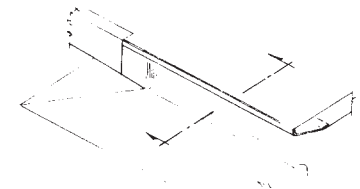

A-3912

**FORMED STEEL FACE PLATE
FOR CATCH BASIN INLETS
Plate No. A-3913, Approximate Weight 12 lbs. per Foot.
For 8" thick slab.**

Furnished with Anchors and Holes for Support Bolts. See Page B-6.

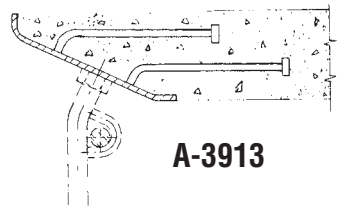
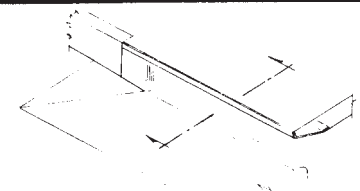

A-3913



A-1563 A-1565

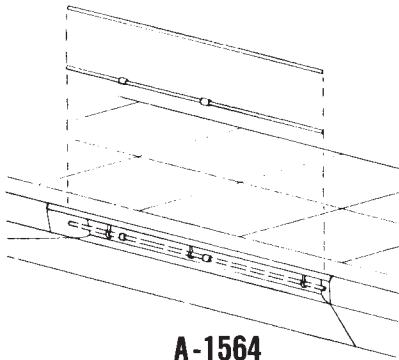

A-1564

**PROTECTION BAR ASSEMBLY
FOR CURB INLETS**

PLATE NUMBER	SIZE BAR	APPROX. WEIGHT	DESCRIPTION
A-1563	1Ø	2.67# per ft.	City of Los Angeles
A-1564	¾Ø	1.5# per ft.	County Road Dept.
A-1565*	¾Ø	1.5# per ft.	L.A.C.F.C.D.

Finish Galvanized.

NOTE: For Curb Angle, See Page B-5, Plate No. A-3901 thru A-3905.

*Used with A-1577.

PROTECTION BAR END ANCHOR

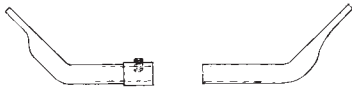
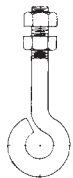

PLATE NUMBER	SIZE BAR	DESCRIPTION AND USE
A-1577	¾Ø	Pipe End Anchors for ¾Ø Bar. L.A.C.F.C.D.

For Use with A-1565 Protection Bar.

A-1577



A-1578

**PROTECTION BAR EYE BOLT HANGER
FOR USE WITH A-1564
SIZE 5/8 x 4" SHANK**

PROTECTION BAR SUPPORT BOLTS

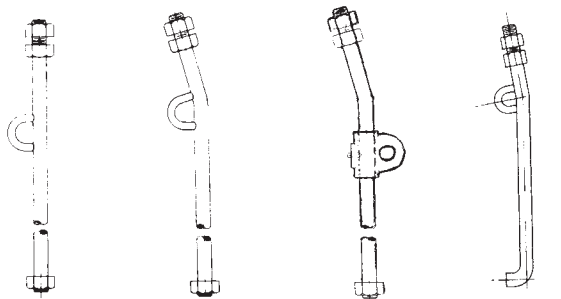

A-1570
A-1571

A-1572
A-1573

A-1574
A-1575

A-1576

PLATE NUMBER	SIZE BAR	DESCRIPTION AND USE
A-1569	1Ø x 1-4½	Clark County STD
A-1570	1Ø x 1-3½	Support Bolt L.A. Co. Rd. Type
A-1571	1Ø x 1-3½	Support Bolt Less Eye
A-1572	1Ø x 1-9	Support Bolt L.A. City Type
A-1573	1Ø x 1-9	Support Bolt Less Eye
A-1574	1Ø x 1-6½	*Support Bolt L.A.C.F.C.D. Type
A-1575	1Ø x 1-6½	Support Bolt Less Eye
A-1576	1Ø x 1-6½	Support Bolt - State Calif.
A-1579	1Ø x 1-6½	Orange County, Ventura County

*Adjustable Eye



**SQUARE
and
RECTANGULAR
COVERS GRATES
and FRAMES**

***Area Drainage Castings, Traffic
and Non-Traffic***

Traffic Steel Grates and Frames

Square and Rectangular Grates
and Frames

Catch Basin Grates and Frames

Trench Grates and Frames

Recessed Covers for Concrete or
Terrazzo Fill

Round Covers, Grates and Frames
Clay Pipe and Soil Pipe Grates

Culvert Covers and Frames

Solid Cover and Frames

Navy type Grates and Frames

Rail Reinforcing for Street Culverts

Tree Well Grates and Frames



**GRATE AND FRAME
FOR CATCH BASIN INLETS
FOR TRAFFIC**

Conforms to various City and County Standards

PLATE NUMBER	NET OPENING	HEIGHT FRAME	SIZE BARS GRATING	NUMBER BARS GRATING	APPROX. WEIGHT
A-1540	25½ x 35¾	4	½ x 3½	16	475
A-1542	24 x 35¾	4	½ x 3½	15	446
A-1544	18 x 35¾	4	½ x 3½	9	312
A-1545	25½ x 35¾	4	½ x 3½	20	560

Multiple Units Made Up By Use of 5" — 18.9 Pound H Beam Supports. Length As Required, with ½" Machine Bolts Furnished to Secure Frame to Beam. Galvanized or Painted Bituminous Paint.

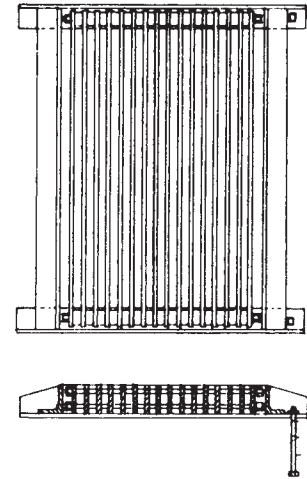

A-1540

**GRATE AND FRAME
FOR CATCH BASIN INLETS
FOR TRAFFIC**

Conforms to State of Calif., Orange and Ventura County Stds.
Nelson Studs Welded to Frame for Anchors.

PLATE NUMBER	TYPE	NET OPENING	HEIGHT FRAME	SIZE BARS GRATING	NUMBER BARS	APPROX. WEIGHT
A-1551	18-9	18 x 35¾	4	½ x 3½	9	288
A-1552	24-9	24 x 35¾	4	½ x 3½	9	316
A-1553	24-12	24 x 35¾	4	½ x 3½	12	365
A-1554	24-15	24 x 35¾	4	½ x 3½	15	423
A-1557	24-18	24 x 35¾	4	½ x 3½	18	495

Galvanized or Painted Bituminous Paint.

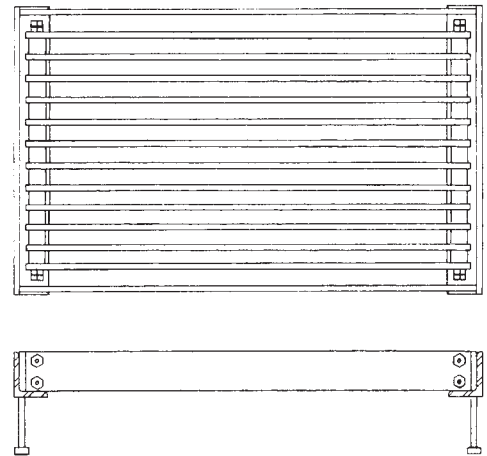

A-1551

**BICYCLE PROOF DUCTILE IRON GRATE
FOR TRAFFIC**

Strength of Steel — Corrosion Quality of Iron — 60% Drainage Area
Fits existing City and County of Los Angeles.
State Highway, Orange and Ventura County Standards

A-1546			A-1555		
GRATE SIZE	APPROX. WEIGHT	FRAME	GRATE SIZE	APPROX. WEIGHT	FRAME
25½ x 40	160	A-1540 A-1545	23¾ x 40	145	A-1542 A-1552 A-1553 A-1554 A-1557

Painted: Bituminous Paint. (Galvanized on Special Order.)

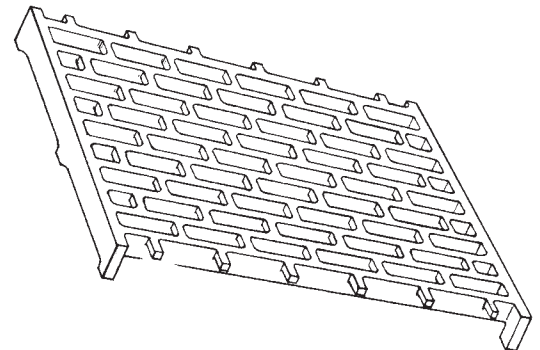

A-1546 and A-1555

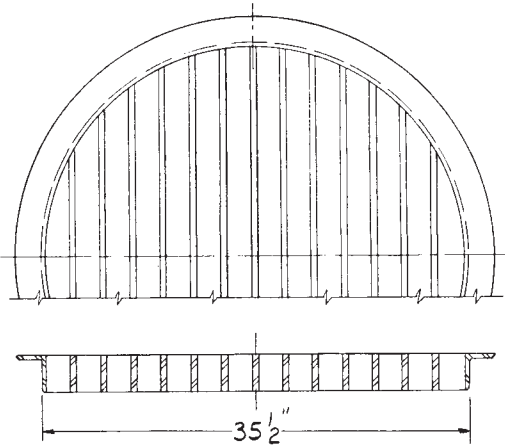

A-1558

**CIRCULAR STEEL GRATE
FOR TRAFFIC**

PLATE NUMBER	PIPE SIZE	APPROX. WEIGHT
A-1558-24	24"	90
A-1558-36*	36"	228
A-1558-48	48"	380

* Conforms to State Standard 36R.
Finish — Galvanized.

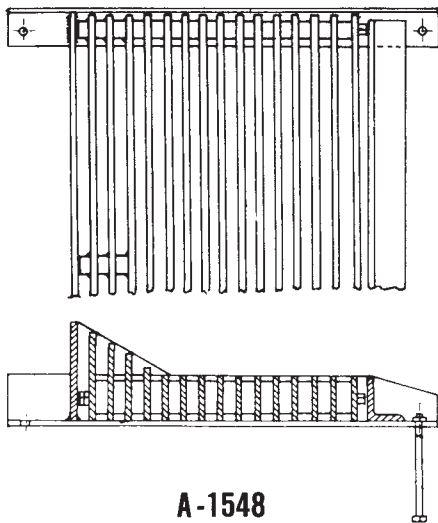

A-1548

**CATCH BASIN GRATE AND FRAME
FOR ROLLED GUTTER
FOR TRAFFIC**

PLATE NUMBER	NET OPENING	FRAME OVERALL	HEIGHT FRAME	TOTAL HEIGHT	APPROX. WEIGHT
A-1548	24 x 35 5/8	35 x 42	4	8 1/2	530

Conforms to Various City, County and State Standards.
Galvanized or Bituminous Paint.

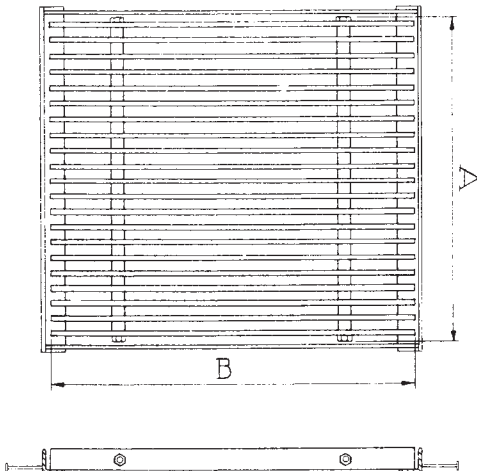

A-1580

**SCHOOL BOARD TYPE
CATCH BASIN GRATE AND FRAME
NON -TRAFFIC**

PLATE NUMBER	CLEAR OPENING	GRATE SIZE A x B	HEIGHT	APPROX WEIGHT	SIZE BARS
A-1581	12 x 18	11 3/4 x 20 1/2	1 1/2	46	3/8 x 1 1/2
A-1583	18 x 24	23 3/4 x 20 1/2	1 1/2	90	3/8 x 1 1/2
A-1584	18 x 30	29 3/4 x 20 1/2	1 1/2	111	3/8 x 1 1/2
A-1585	24 x 24	23 3/4 x 26 1/2	1 1/2	111	3/8 x 1 1/2
A-1586	24 x 36	35 3/4 x 26 1/2	1 1/2	162	3/8 x 1 1/2

Special Sizes Made to Order.
Finish — Galvanized.
NOTE: "B" Dimension is Length of Bearing Bars.

NOTE: Grates Now Comply with the American Disabilities Act on Slot Size.



**RAISED GRATE CATCH BASIN GRATE AND FRAME
NON-TRAFFIC**

PLATE NUMBER	CLEAR OPENING	OUTSIDE FRAME	HEIGHT FRAME	TOTAL HEIGHT	SIZE TOP	APPROX. WEIGHT
A-1850	26	30	4	9 $\frac{5}{8}$	12	175

Painted: Bituminous Paint.

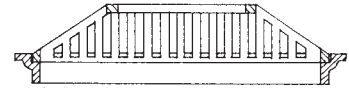
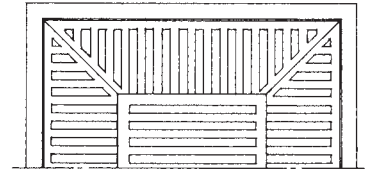

A-1850

**CONCAVE GRATE CATCH BASIN GRATE AND FRAME
FOR TRAFFIC**

PLATE NUMBER	CLEAR OPENING	OVERALL BASE	HEIGHT FRAME	APPROX. WEIGHT
A-1855	28 $\frac{3}{8}$	37 $\frac{5}{8}$	5 $\frac{1}{4}$	525

Painted: Bituminous Paint.

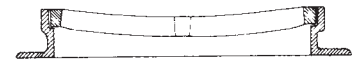
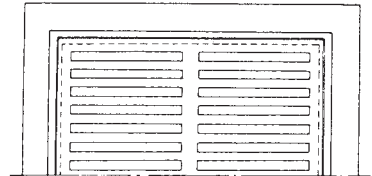

A-1855

**FEDERAL STANDARD
CAST IRON GRATE AND FRAME
FOR TRAFFIC**

PLATE NUMBER	CLEAR OPENING	OUTSIDE FRAME	HEIGHT FRAME	APPROX. WEIGHT
A-1856	30 x 30	38 x 38	6	655

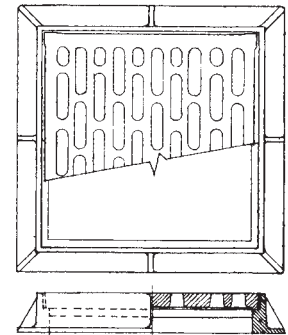

A-1856

**CAST IRON HIGHWAY GRATE AND FRAME
FOR TRAFFIC**

PLATE NUMBER	CLEAR OPENING	OUTSIDE FRAME	HEIGHT FRAME	APPROX. WEIGHT
A-1281	25 x 33 $\frac{1}{2}$	29 x 37 $\frac{1}{2}$	1 $\frac{3}{4}$	255

Conforms to State of California Standards.

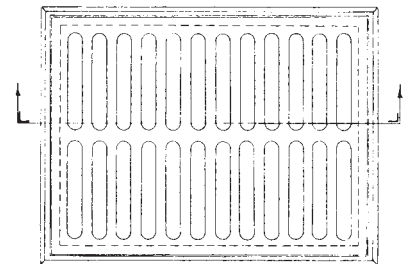

A-1281

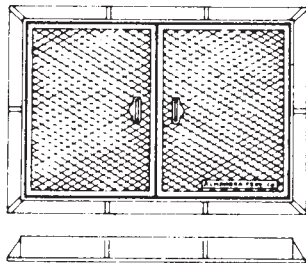

A-1341

**COVER AND FRAME
NON-TRAFFIC — SPLIT COVERS**

PLATE NUMBER	CLEAR OPENING	OVERALL BASE	HEIGHT FRAME	APPROX. WEIGHT
A-1341	36 x 54	41 x 59	4	890
A-1342	24 x 48	33 x 57	3	460
A-1343	48 x 60	54 x 66	4	1120

Raised Diamond Tread. Drop Lift Handles. Covers Carefully Ground to Fit Frames. Painted: Bituminous Paint.

**COVER AND FRAME
NON-TRAFFIC — SINGLE COVER**

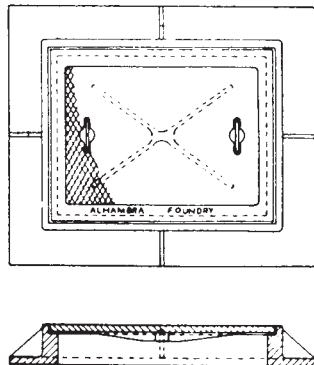

A-17551

PLATE NUMBER	CLEAR OPENING	OVERALL BASE	HEIGHT FRAME	APPROX. WEIGHT
A-17551	36 x 36	42 x 42	4	550
A-17552	30 x 36	40 x 46	6	590
A-17553	30 x 30	36 x 36	3	305
A-17555	27 x 27	37 x 37	4 1/4	325
A-17556	25 x 31	32 x 38	4	365
A-17557	24 x 36	34 x 46	4	530
A-17558	24 x 30	37 x 43	6	360
A-17560	24 x 24	33 x 33	3	300
A-17562	23 1/2 x 23 1/2	29 x 29	3	255
A-17563	20 x 30	28 x 38	4	280

Diamond Tread. Drop Lift handles. Cover and Frame Carefully Fitted. Painted: Bituminous Paint.

**RECTANGULAR COVER AND FRAME
FOR TRAFFIC**

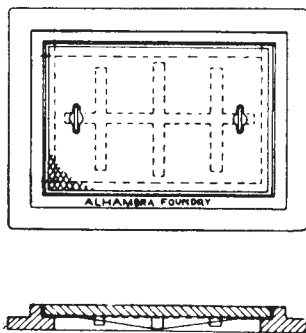

A-13700

PLATE NUMBER	CLEAR OPENING	OVERALL BASE	HEIGHT FRAME	APPROX. WEIGHT
A-13701*	36 x 48	44 x 56	4	1060
A-13702	36 x 36	44 x 44	4	950
A-13704	30 x 30	40 x 40	4 3/4	830
A-13705	24 x 51	33 x 60	4	750
A-13706	24 x 36	33 x 46	4	740
A-13707	24 x 30	33 x 40	3	665
A-13708	24 x 24	30 x 30	3	370
A-13709	18 x 24	25 x 31	2 1/2	310

* Note: This Size Furnished With Split Covers.
Diamond Tread. Drop Lift Handles. Cover Ground to Fit Frame. Painted: Bituminous Paint.



**SIDEWALK TYPE CATCH BASIN FRAME
WITH 3-SECTION COVER
NON-TRAFFIC**

PLATE NUMBER	CLEAR OPENING	OVERALL FLANGE	HEIGHT FRAME	APPROX. WEIGHT
A-1470	20 x 52	30 x 62	4	450

Diamond Tread. Lift Holes. Covers and Frames Carefully Fitted. Bolted Down with Hex Head Set Screws. Painted: Bituminous Paint. Conforms L.A. County Road Dept. No. 5.

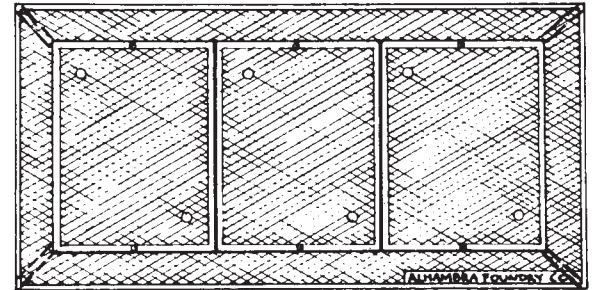

A-1470

**RECTANGULAR MANHOLE FRAME
WITH 2-SECTION COVER
FOR TRAFFIC**

PLATE NUMBER	CLEAR OPENING	OVERALL FLANGE	HEIGHT FRAME	APPROX. WEIGHT
A-1471	24 x 50	31 x 57	3½	645
A-1472*	24 x 72	30 x 78	4¼	950
A-1473	30 x 48	56½ x 55	2½	740

Diamond Tread. Lift Holes. Cover and Frame Carefully Fitted. Painted: Bituminous Paint. Conforms to L.A. County Dwg. No. S-16.

*Three Section Cover in a Fabricated Steel Frame. Each Cover Secured with Four Stainless Hex Head Cap Screws.

Note: A-1473 Conforms to Southern Calif. Edison Standards, Covers Marked EDISON.

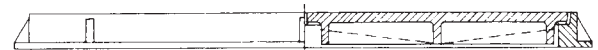
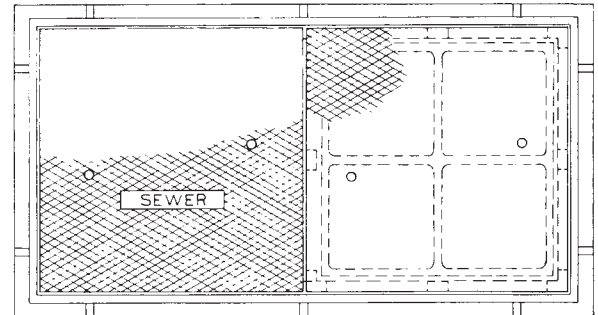

A-1471

**CATCH BASIN COVER AND FRAME
NON-TRAFFIC**

PLATE NUMBER	CLEAR OPENING	COVER SIZE	OVERALL BASE	HEIGHT FRAME	APPROX. WEIGHT
A-1450	12 x 18¼	13 x 19	15 x 21	1½	54
A-1451	17 x 21½	18 x 22	20 x 24	1½	85
A-1452	18 x 24¼	19 x 25	21½ x 27½	1½	95
A-1453	18 x 36	19 x 37	22¼ x 40¼	1½	138

Diamond Tread. Cover and Frame Carefully Fitted. Painted: Bituminous Paint. Lettered to Suit.

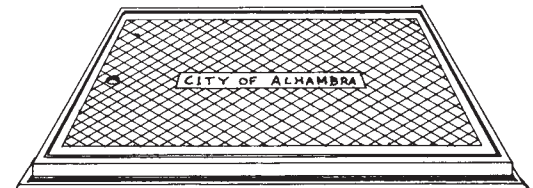

A-1450



RECTANGULAR COVER AND FRAME
LOS ANGELES CITY AND COUNTY STANDARDS
NON-TRAFFIC

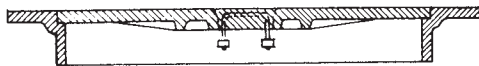
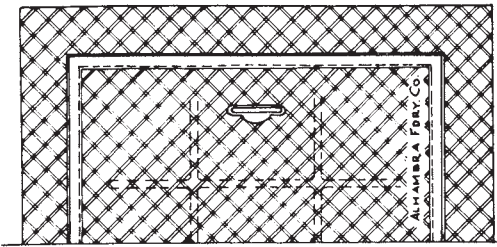

A-14600

PLATE NUMBER	CLEAR OPENING	OVERALL BASE	HEIGHT FRAME	APPROX. WEIGHT
A-14601	36 x 48	44 x 57	3½	540
A-14602	30 x 30	40 x 40	4½	390
A-14603	24 x 24	34 x 34	4½	290
A-14604	22 x 34	32 x 44	3	365
A-14605	21 x 48	31 x 58	3½	435
A-14606	21 x 35	31 x 46	4	426
A-14608*	16¼ x 20½	24¾ x 28¾	4	175
A-14609	16 x 43	26 x 53	4	340
A-14610	16 x 20	26 x 30	4½	210
A-14612	24 x 36	27 x 39	3	190

* L.A. County-DC-18-Galvanized Round Corners.
Raised Square Tread. Cover and Frame Carefully Fitted. Drop Lift Handles. Painted: Bituminous Paint.

GOVERNMENT TYPE CLEANOUT
COVER AND FRAME
NON-TRAFFIC

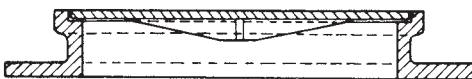
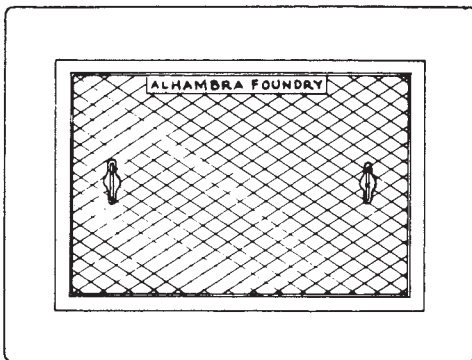

A-13900

PLATE NUMBER	CLEAR OPENING	OVERALL BASE	HEIGHT FRAME	APPROX. WEIGHT
A-13902	24 x 30	33 x 39	4	300
A-13903*	24 x 24	40 x 40	6	415
A-13905	22 x 40	31 x 46	4	350
A-13906	22 x 34	31½ x 43½	4	320
A-13907	21½ x 36	31 x 46	4½	335
A-13908	20 x 32	29 x 41	4	275
A-13909	18 x 30	27 x 39	4	235
A-13910	16 x 28	25 x 37	4	210
A-13911	10 x 16	19 x 25	4	110
A-13912	30 x 30	38 x 38	4	380
A-13913	30 x 36	39 x 45	4¾	460

Diamond Tread. Drop Lift Handles. Cover and Frame Carefully Fitted. Painted: Bituminous Paint.

* Traffic Type.



**FABRICATED STEEL FRAME AND COVER
FOR CONCRETE OR TERRAZZO FILL
NON-TRAFFIC**

PLATE NUMBER	CLEAR OPENING	OVERALL DIMENSION	HEIGHT FRAME	APPROX. WEIGHT
A-1999	18 $\frac{1}{8}$ x 28 $\frac{1}{8}$	19 $\frac{1}{2}$ x 29 $\frac{1}{2}$	4	70

Conforms to City of Pasadena Standard Drawing #S-904, Galvanized. Other Sizes Can Be Made to Order.

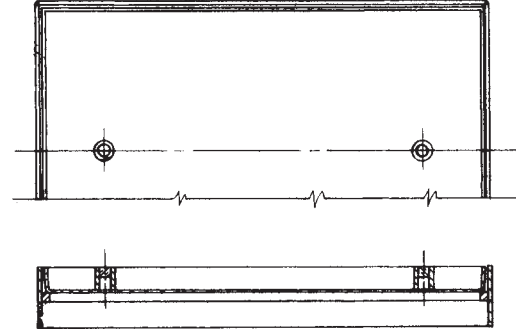

A-1999

**RECTANGULAR COVER AND FRAME
FOR CONCRETE OR TERRAZZO FILL
NON-TRAFFIC**

PLATE NUMBER	CLEAR OPENING	OVERALL FLANGE	HEIGHT FRAME	APPROX. WEIGHT
A-2001	10 $\frac{1}{2}$ x 16 $\frac{1}{2}$	14 $\frac{1}{2}$ x 20 $\frac{1}{2}$	2 $\frac{1}{2}$	67
A-2002	16 $\frac{1}{2}$ x 28 $\frac{1}{2}$	20 $\frac{1}{2}$ x 32 $\frac{1}{2}$	2 $\frac{1}{2}$	120

Cover Carefully Ground to Fit Frame. Painted; Bituminous Paint.

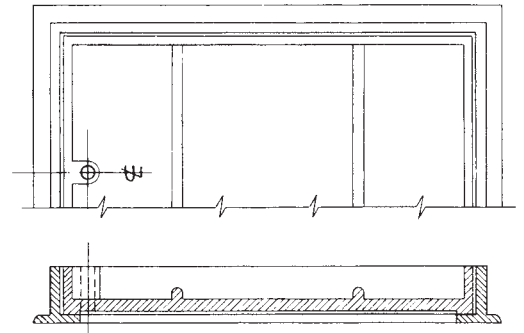

A-2000

**MANHOLE COVER AND FRAME
TELEPHONE TYPE — FOR NON-TRAFFIC
RECESSED FOR CONCRETE OR TERRAZZO**

PLATE NUMBER	CLEAR OPENING	OVERALL FLANGE	HEIGHT	APPROX. WEIGHT
A-1137	27	34	2 $\frac{3}{4}$	180
A-1138	30	37	2 $\frac{3}{4}$	260

Machined to Fit. Stainless Steel Lifting Devices.

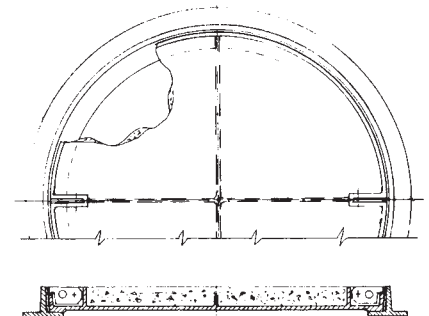

A-1137

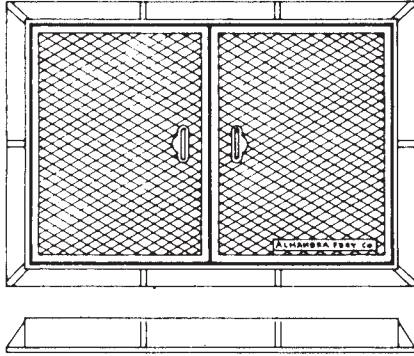

A-1430

**RECTANGULAR COVER AND FRAME
FOR TRAFFIC**

PLATE NUMBER	CLEAR OPENING	OVERALL BASE	HEIGHT FRAME	APPROX. WEIGHT
A-1430	42 x 54	53 x 65	4½	1740
A-1431	44 x 48	54 x 58	4½	1420
A-1432	42 x 42	53 x 53	4½	1450
A-1433	36 x 54	46 x 64	4½	1300
A-1434	36 x 48	44 x 56	4	1000
A-1435	24 x 42	33 x 51	4½	675

Raised Diamond Tread. Drop Lift Handles. Cover Carefully Ground to Fit Frame. Painted: Bituminous Paint.

**RECTANGULAR COVER AND FRAME
FOR TRAFFIC**

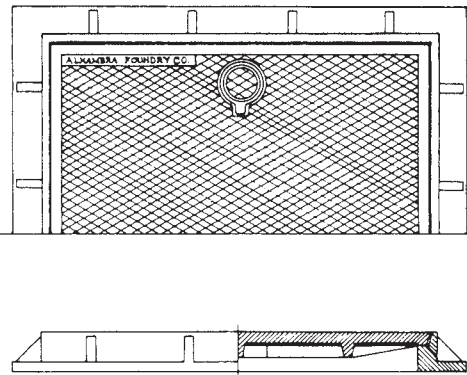

A-14410

PLATE NUMBER	CLEAR OPENING	OVERALL BASE	HEIGHT FRAME	APPROX. WEIGHT
A-14411	36 x 36	46 x 46	4	1075
A-14412	34 x 34	44 x 44	6½	990
A-14413	30 x 36	40 x 46	6	852
A-14414	28 x 32	38 x 42	7	730
A-14415	24 x 24	34 x 34	4½	450
A-14416	24 x 36	33 x 45	4	720
A-14417	24 x 28	38 x 42	4	575
A-14418	24 x 26	30 x 32	3½	335
A-14419	24 x 24	32 x 32	6	405
A-14421	18 x 24	27 x 33	6	457
A-14423	16 x 16	36 x 36	6½	415
A-14424	14 x 21	28 x 48	5¼	425
A-14425	12 x 18	22 x 27	6	225

Raised Diamond Tread. Drop Handles. Cover Carefully Ground to Fit Frame. Painted: Bituminous Paint.



**HINGED VALVE COVER AND FRAME
GOVERNMENT PATTERN — NON-TRAFFIC**

PLATE NUMBER	CLEAR OPENING	OVERALL BASE	HEIGHT FRAME	APPROX. WEIGHT
A-1330	18 x 35	22½ x 39½	4	190
A-1331	13½ x 34½	18 x 39½	4	162
A-1332	12½ x 24	16¾ x 28¾	4	95
A-1333	11½ x 18	16¼ x 22¾	4	70
A-1334	11¾ x 12½	16¾ x 17½	4	50

Diamond Tread. Heavy Integral Cast Hinges. Painted: Bituminous Paint. Drop Lift Handle.

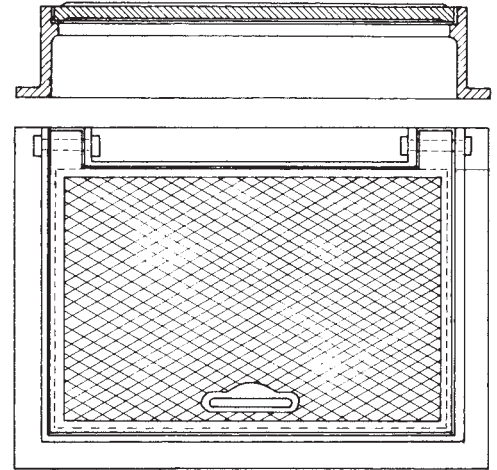

A-1330

**HINGED COVER AND FRAME
WITH RACHET LIFT
NON-TRAFFIC**

PLATE NUMBER	CLEAR OPENING	OVERALL FLANGE	HEIGHT FRAME	APPROX. WEIGHT
A-1401	30 x 36	35 x 41	3	225
A-1402	22½ x 22½	28 x 28	3	135
A-1403	19½ x 19½	24½ x 24½	3	105
A-1404	24 x 30	30¾ x 36¾	3	175

Diamond Tread. Painted: Bituminous Paint.
Flush Cast Link Hinges.

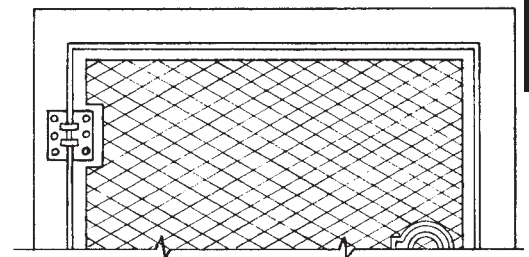

C

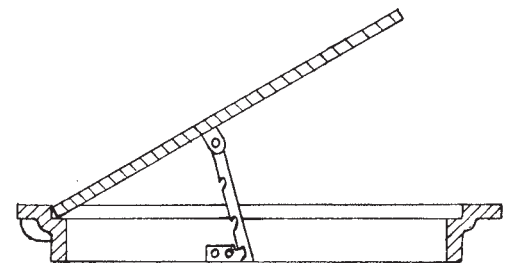

A-1400

**HINGED ACCESS COVER AND FRAME
FOR TRAFFIC**

PLATE NUMBER	CLEAR OPENING	OVERALL FLANGE	HEIGHT FRAME	APPROX. WEIGHT
A-2310	11	14	1½	40

Offers Quick Access to Utility Outlets Located in Traffic Areas. Specify Either Slot or Pick Hole.

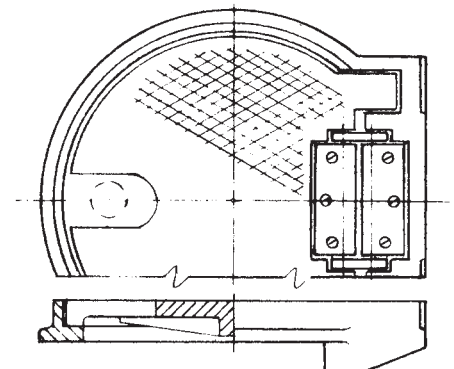

A-2310

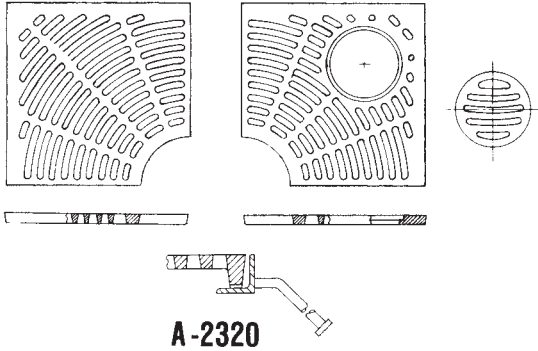

A-2320

**CAST IRON TREE WELL GRATES
ORNAMENTAL TREE GUARDS
AVAILABLE ON REQUEST**

60" Square with 16" Dia. Center Opening. Cast in Quarter Sections. Furnished with or without 12" Dia. Removable Section For Ground Lighting. Furnished with Grating Support and Frame. Painted: Bituminous Paint Unless Otherwise Specified. 360 lbs. Approximate Weight.

NOTE: A2331 Available with Narrow Slots for High Heel Shoe Area.

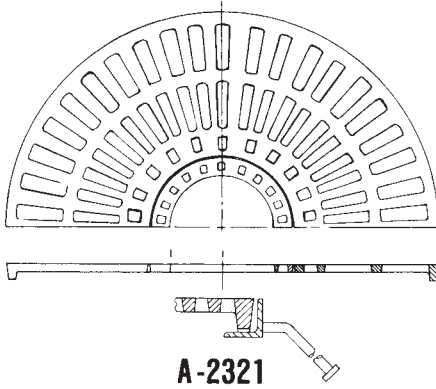

A-2321

**CAST IRON TREE WELL GRATES
ORNAMENTAL TREE GUARDS
AVAILABLE ON REQUEST**

42" Diameter With 10" or 14" Dia. Center Opening. Cast in Half Sections. Frame Available on Request. Painted: Bituminous Paint Unless Otherwise Specified. 360 lbs. Approximate Weight. Grates Bolted to Frame if Required.

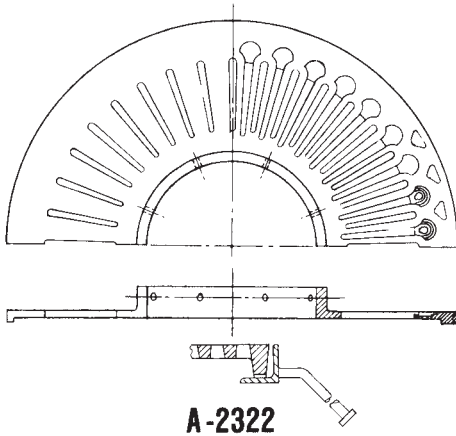

A-2322

**CAST IRON TREE WELL GRATES
ORNAMENTAL TREE GUARDS
AVAILABLE ON REQUEST**

48" Dia. With 18" Dia. Center Opening. Cast in Half Sections. Frame Available on Request. Painted Bituminous Paint Unless Otherwise Specified. 325 lbs. Approximate Weight. Grates Bolted to Frame if Required.

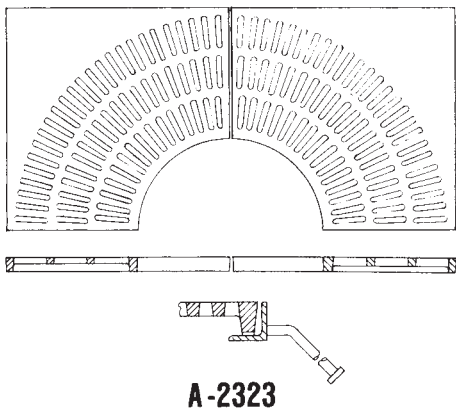

A-2323

**CAST IRON TREE WELL GRATES
ORNAMENTAL TREE GUARDS
AVAILABLE ON REQUEST**

48" Square with 19 1/8" Dia. Center Opening. Cast in Quarter Sections. Supplied with Grating Support and Frame. Painted: Bituminous Paint Unless Otherwise Specified. 320 lbs. Approximate Weight.

NOTE: Grate Complies with the American Disabilities Act with 1/2" Wide Slots.



**CAST IRON TREE WELL GRATES
ORNAMENTAL TREE GUARDS
AVAILABLE ON REQUEST**

72" x 72" with 18" x 18" Center Opening. Cast in Quarter Sections. Supplied with Grating Support and Frame. Painted: Bituminous Paint Unless Otherwise Specified. 570 lbs. Approximate Weight.

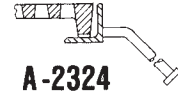
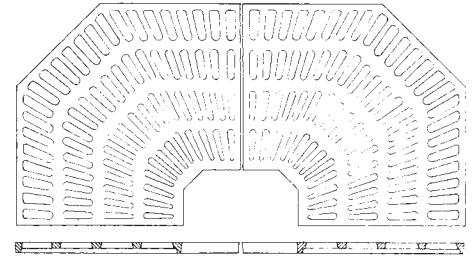

A-2324

**CAST IRON TREE WELL GRATES
ORNAMENTAL TREE GUARDS
AVAILABLE ON REQUEST**

36" Square with 15" Dia. Center Opening. Cast in Half Sections. Supplied with Frame. Painted: Bituminous Paint Unless Otherwise Specified. 200 lbs. Approximate Weight. Grates Bolted to Frame if Required.

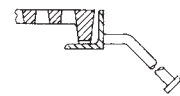
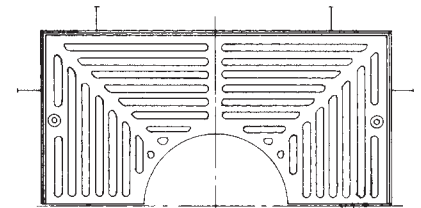

A-2325

C

NOTE: Grate Complies with the American Disabilities Act with 1/2" Wide Slots.

**CAST IRON TREE WELL GRATES
ORNAMENTAL TREE GUARDS
AVAILABLE ON REQUEST**

48" Square with 12" Dia. Center Opening. Grate Opening Expandable, May Be Cut Out as Tree Grows. Cast in 2 Half Sections. Can Be Supplied with Frame. Grate Can Be Bolted Together Around Tree. Painted: Black Bituminous Paint Unless Otherwise Specified. 300 lbs. Approximate Weight.

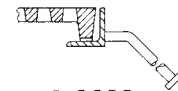
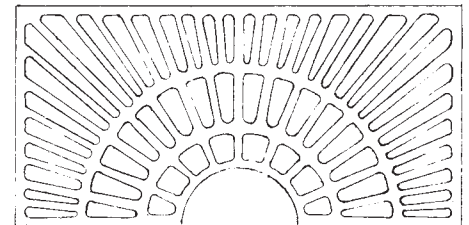

A-2326

**CAST IRON TREE WELL GRATES
ORNAMENTAL TREE GUARDS
AVAILABLE ON REQUEST**

36" Square with 9" Dia. Center Opening. Grate Opening Expandable, Can Be Cut Out as Tree Grows. Cast in 2 Half Sections. Can Be Supplied with Frame. Grate Can Be Bolted Together Around Tree. Painted: Black Bituminous Paint Unless Otherwise Specified. 150 lbs. Approximate Weight.

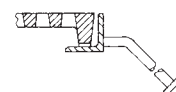
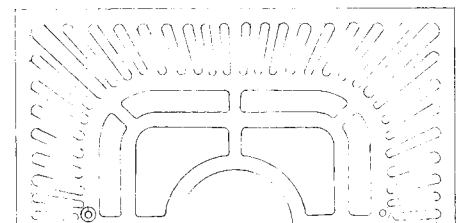

A-2327

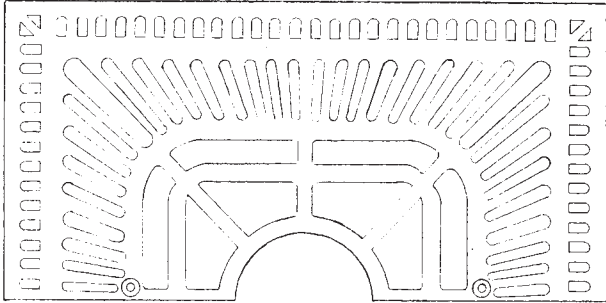

A-2329

**CAST IRON TREE WELL GRATES
ORNAMENTAL TREE GUARDS
AVAILABLE ON REQUEST**

42" Square with 9" Dia. Center Opening. Grate Opening Expandable. Can Be Cut Out as Tree Grows. Cast in 2 Half Sections. Can Be Supplied with Frame. Grate Can Be Bolted Together Around Tree. Painted: Black Bituminous Paint Unless Otherwise Specified. 150 lbs. Approximate Weight. Conforms to City of West Covina Standards.

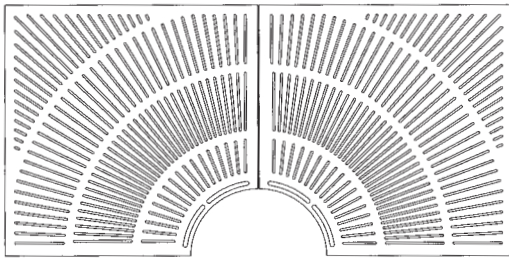

A-2331

**ADA AND HIGH HEEL PROOF
CAST IRON TREE WELL GRATES
ORNAMENTAL TREE GUARDS
AVAILABLE ON REQUEST**

60" Square with 16" Diameter Center Opening Cast in Quarter Sections Supplied with Grating Support and Frame Painted Bituminous Paint Unless Otherwise Specified. 462 lbs Approximate Weight.

A-2330 FABRICATED STEEL TREE GUARDS

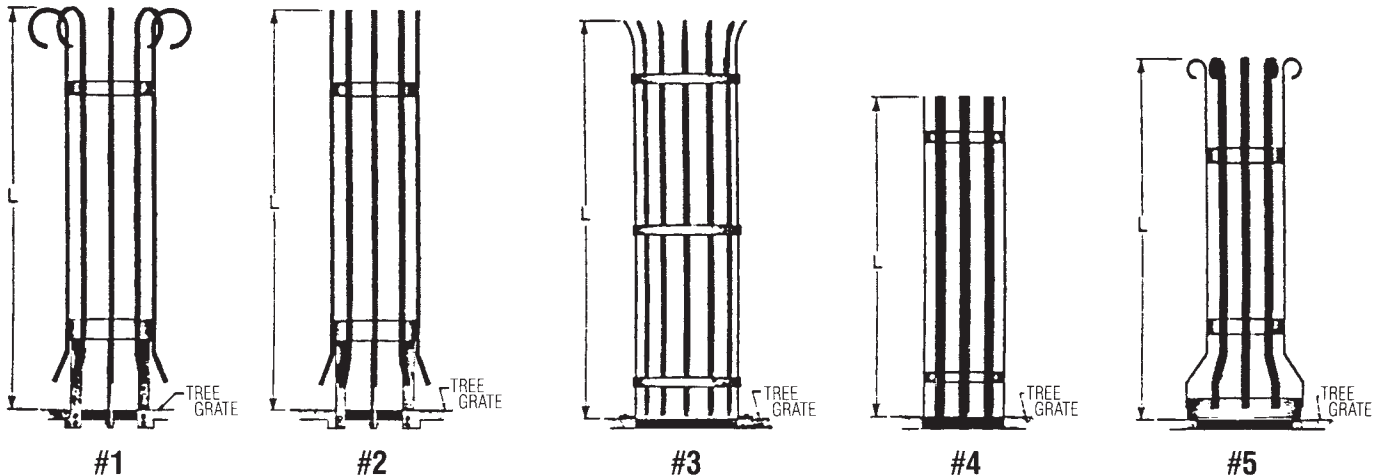

A-2330 Tree Guards Fabricated from Hot Rolled Steel. Guards Designed to Fit Different Cast Iron Tree Grates. When Ordering, Specify Design Number and Size Required. Guards Furnished Unfinished as Standard. Optional Galvanized Finish Available.

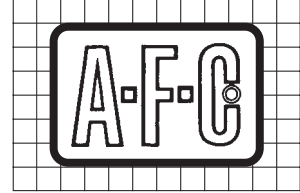

CAST IRON TREE WELL GRATES
ORNAMENTAL TREE GUARDS
AVAILABLE ON REQUEST

48" Square With 17 1/2" Dia. Center Opening. Cast In Half Sections Supplied With Frame. Painted: Bituminous Paint Unless Otherwise Specified 243 lbs. Approximate Weight.

Note: Grate Complies With The Americans With Disabilities Act With 1/2" Wide Slots.

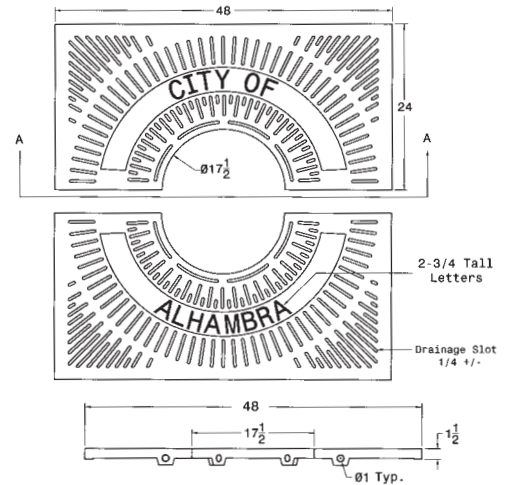

A-2332

CAST IRON TREE WELL GRATES
ORNAMENTAL TREE GUARDS
AVAILABLE ON REQUEST

36" Square With 16 1/2" Dia. Center Opening. Cast In Half Sections Supplied With Frame. Painted: Bituminous Paint Unless Otherwise Specified 200 lbs. Approximate Weight.

Note: Grate Complies With The Americans With Disabilities Act With 1/2" Wide Slots.

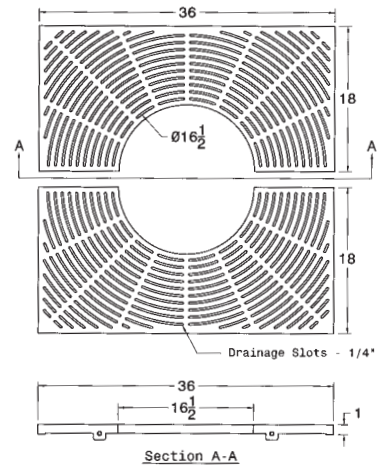

A-2333

CAST IRON TREE WELL GRATES
ORNAMENTAL TREE GUARDS
AVAILABLE ON REQUEST

48" Square With 15 3/4" Dia. Center Opening. Cast In Half Sections Supplied With Frame. Painted: Bituminous Paint Unless Otherwise Specified 362 lbs. Approximate Weight.

Note: Grate Complies With The Americans With Disabilities Act With 1/2" Wide Slots.

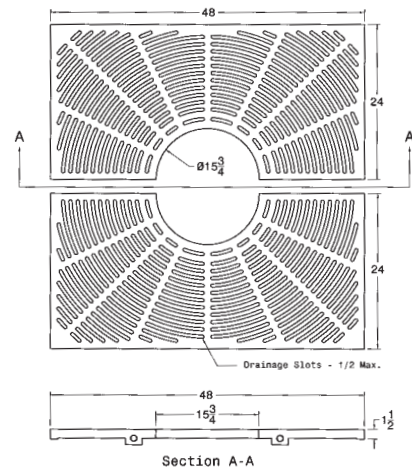

A-2334

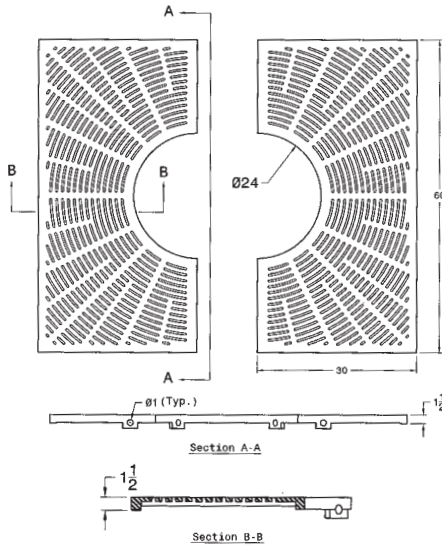

**CAST IRON TREE WELL GRATES
ORNAMENTAL TREE GUARDS
AVAILABLE ON REQUEST**

60" Square With 24" Dia. Center Opening. Cast In Half Sections Supplied With Frame. Painted: Bituminous Paint Unless Otherwise Specified 480 lbs. Approximate Weight.

Note: Grate Complies With The Americans With Disabilities Act With 1/2" Wide Slots.

A-2335

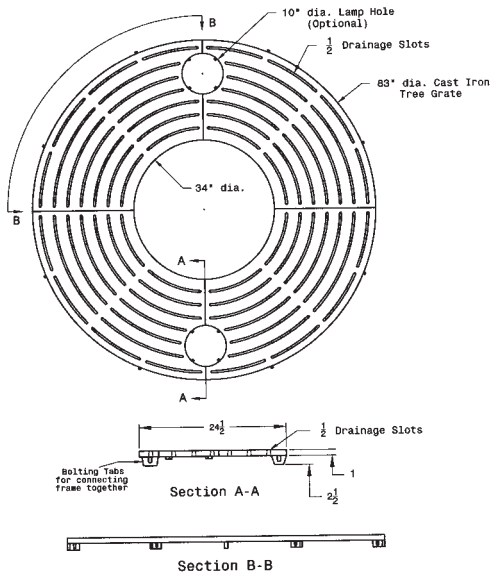

**CAST IRON TREE WELL GRATES
ORNAMENTAL TREE GUARDS
AVAILABLE ON REQUEST**

83" Square With 34" Dia. Center Opening. Cast In Quarter Sections Supplied With Frame. Painted: Bituminous Paint Unless Otherwise Specified 800 lbs. Approximate Weight.

Note: Grate Complies With The Americans With Disabilities Act With 1/2" Wide Slots.

A-2336

★ — signifies more favorable stock and volume production



CULVERT MANHOLE COVER AND FRAME

FOR TRAFFIC

PLATE NUMBER	CLEAR OPENING	APPROX. WEIGHT
A-1360	14½ x 20½	500

60 Pound Rail Supports. Conforms to City of Los Angeles B2522.

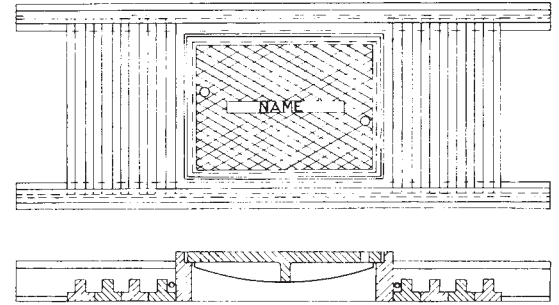

A-1360

MULTIPLE CAST STEEL COVER AND STRUCTURAL STEEL FRAME FOR SANITARY SEWER FOR TRAFFIC

**PLATE NUMBER A-1363
TABLE OF DIMENSIONS**

DIM.	NUMBER OF COVERS							
	1	2	3	4	5	6	7	8
A	1'6"	2'9"	4'2"	5'7"	7'0"	8'5"	9'10"	11'3"
B	—	—	1	2	3	4	5	6
C	0'9"	2'0"	3'5"	4'10"	6'3"	7'8"	9'1"	10'6"

ALL COVERS 15¾" x 23¾"

Conforms to City of Los Angeles B3019. "H" is 12" Unless Otherwise Specified. Apply to Office for Prices and Drawings to Meet Varying Conditions.

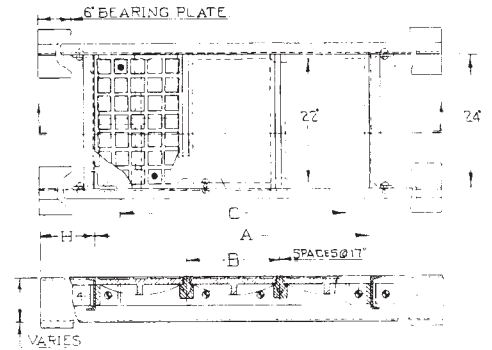

A-1363

RAIL TOP BOX CULVERT

PLATE NUMBER	WIDTH	LENGTH	WEIGHT
A-1365	24	As Specified	Varies

Conforms to Los Angeles County Road Dept. Drwg. 74-11 Pg. 1 & 2. See Page C-14 for Rail Spacing.

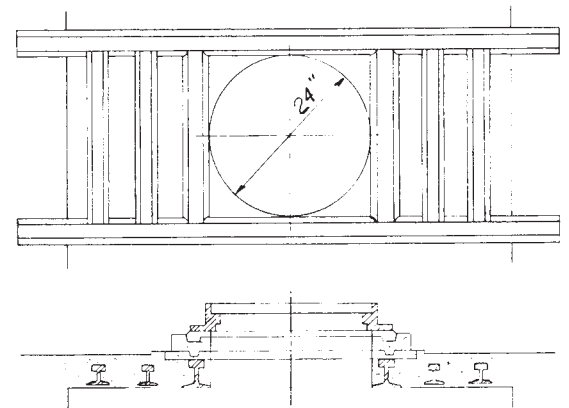

A-1365

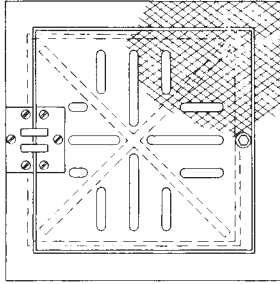

A-2273

CLEANOUT HINGED COVER AND FRAME
Conforms to Los Angeles County Road Department
Dwg. #74-01 for Parkway Drains #1 & #2 Case 1
NON-TRAFFIC

PLATE NUMBER	CLEAR OPENING	OVERALL FLANGE	DEPTH SKIRT	APPROX. WEIGHT
★ A-2273	12 x 12	16 x 16½	2	45

Flush Cast Link Hinges.
Painted: Bituminous Paint.
Conforms to Los Angeles County Road Dept. 62-01. A.P.W.A. - 151-0.

CULVERT FRAME WITH SECTIONAL COVERS
FOR TRAFFIC

PLATE NUMBER	COVERS PER SECT.	CLEAR OPENING A & B	OVERALL FRAME C & D	HEIGHT	APPROX WEIGHT	APPROX. WT. ADDITIONAL COVER
A-1350-2	2	27 x 48	33 x 59	4	970	
A-1350-3	3	40 x 48	45 x 59	4	1396	426
A-1350-4	4	54 x 48	60 x 59	4	1822	
A-1351-2	2	27 x 42	33 x 53	4	900	
A-1351-3	3	40 x 42	46 x 53	4	1294	394
A-1351-4	4	54 x 42	60 x 53	4	1688	
A-1352-2	2	27 x 36	32 x 46	3	590	
A-1352-3	3	40 x 36	45 x 46	3	859	269
A-1352-4	4	54 x 36	59 x 46	3	1128	
A-1353-2	2	27 x 30	32 x 40	3	480	
A-1353-3	3	40 x 30	45 x 40	3	696	216
A-1353-4	4	54 x 30	59 x 40	3	912	

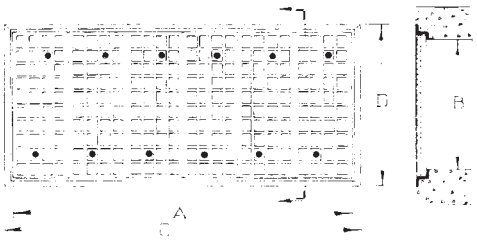

A-1350

Cast Iron Covers Complete with Structural Steel Zee Bar Frame. Covers Have Lift Holes and are machined to Fit Frame. By Adding Additional Covers, a Wide Variety of Lengths Can Be Obtained. Add 13% for Each Additional Cover. Painted: Bituminous Paint.

★ — signifies more favorable stock and volume production



**RAIL REINFORCING FOR STREET CULVERTS
LOS ANGELES COUNTY ROAD DEPARTMENT**

RAIL SPACING

RAIL WEIGHT	D	S	30 LB.	35 LB.	40 LB.	45 LB.	50 LB.	55 LB.	60 LB.	LENGTH
30 LB./YD.	3 1/8"	2'6"	7 1/2"	8 3/4"	10"	10"	10"	10"	10"	3'2"
35 LB./YD.	3 5/16"	3'0"	6 1/2"	7 1/2"	8 1/2"	9 1/4"	10"	10"	10"	3'8"
40 LB./YD.	3 1/2"	3'6"	5 1/2"	6 1/2"	7 1/2"	8 1/4"	9"	10"	10"	4'2"
45 LB./YD.	3 11/16"	4'0"	5"	6"	7"	7 3/4"	8 1/2"	9 1/4"	10"	4'8"
50 LB./YD.	3 7/8"	4'6"	4 1/2"	5 1/2"	6 1/2"	7 1/4"	8"	8 3/4"	9 1/2"	5'2"
55 LB./YD.	4 1/16"	5'0"	4"	5"	6"	6 3/4"	7 1/2"	8 1/4"	9"	5'8"
60 LB./YD.	4 1/4"	5'6"	3 3/4"	4 1/2"	5 1/2"	6 1/4"	7"	7 3/4"	8 1/2"	6'2"
80 LB./YD.	5"	6'0"	3 1/2"	4 1/4"	5"	5 3/4"	6 1/2"	7 1/4"	8"	6'8"

Los Angeles County Road Department Rail Top Box Culvert No. 13. Standard Plan 60-13. See Plate A-1365, Page C-12 for Manhole Cover and Frame.

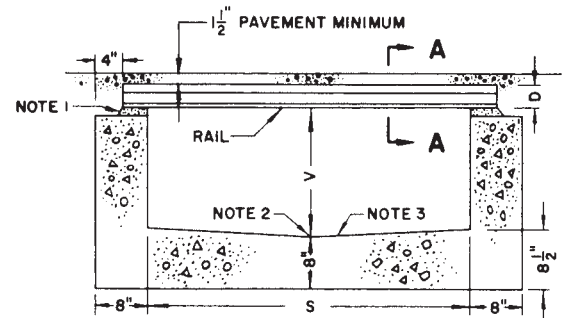

TYPICAL SECTION OF SINGLE BOX

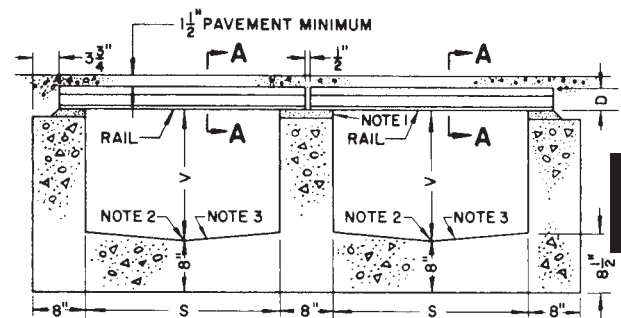

TYPICAL SECTION OF DOUBLE BOX

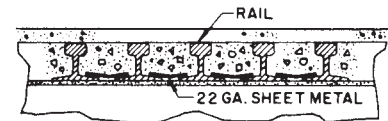

SECTION A-A

CITY OF LOS ANGELES STANDARD CULVERT

**STEEL RAIL SPACING FOR TOP SLAB
IN ROADWAY AND DRIVEWAYS**

All Spacing Dimensions Center to Center

WEIGHT PER YARD	WIDTH OF BASE	CULVERT SPANS				
		2'	3'	4'	5'	6'
20#	2 5/8"	4 1/2"	3"	—	—	—
25#	2 3/4"	5 1/2"	3 3/4"	3"	—	—
30#	3 1/8"	7 3/4"	5 1/2"	4 1/4"	3 1/2"	—
35#	3 5/16"	8 3/8"	6 1/2"	5"	4 1/4"	3 1/2"
40#	3 1/2"	9"	8"	6 1/4"	5"	4 1/4"
45#	3 11/16"	9 3/8"	9 1/4"	7 1/4"	6"	5"
50#	3 7/8"	9 3/4"	9 3/4"	8 1/2"	7"	6"
55#	4 1/16"	10 1/8"	10 1/8"	9 3/4"	8"	6 3/4"
60#	4 1/4"	10 1/2"	10 1/2"	10 1/2"	9 1/4"	7 3/4"
65#	4 7/16"	10 7/8"	10 7/8"	10 7/8"	10 1/4"	8 3/4"
70#	4 5/8"	11 1/4"	11 1/4"	11 1/4"	11 1/4"	9 3/4"

Conforms to City of Los Angeles Standard Plan DL-2327.

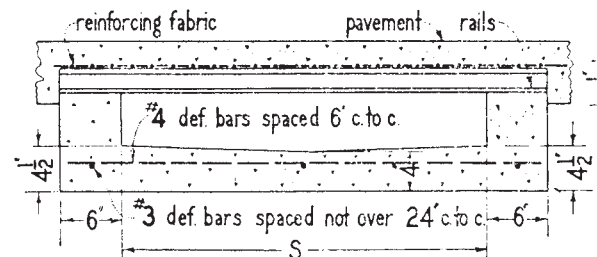

SECTION OF SINGLE CULVERT WITH RAIL TOP



**FABRICATED STEEL SIDEWALK CULVERT
CHECKERED PLATE COVERS**

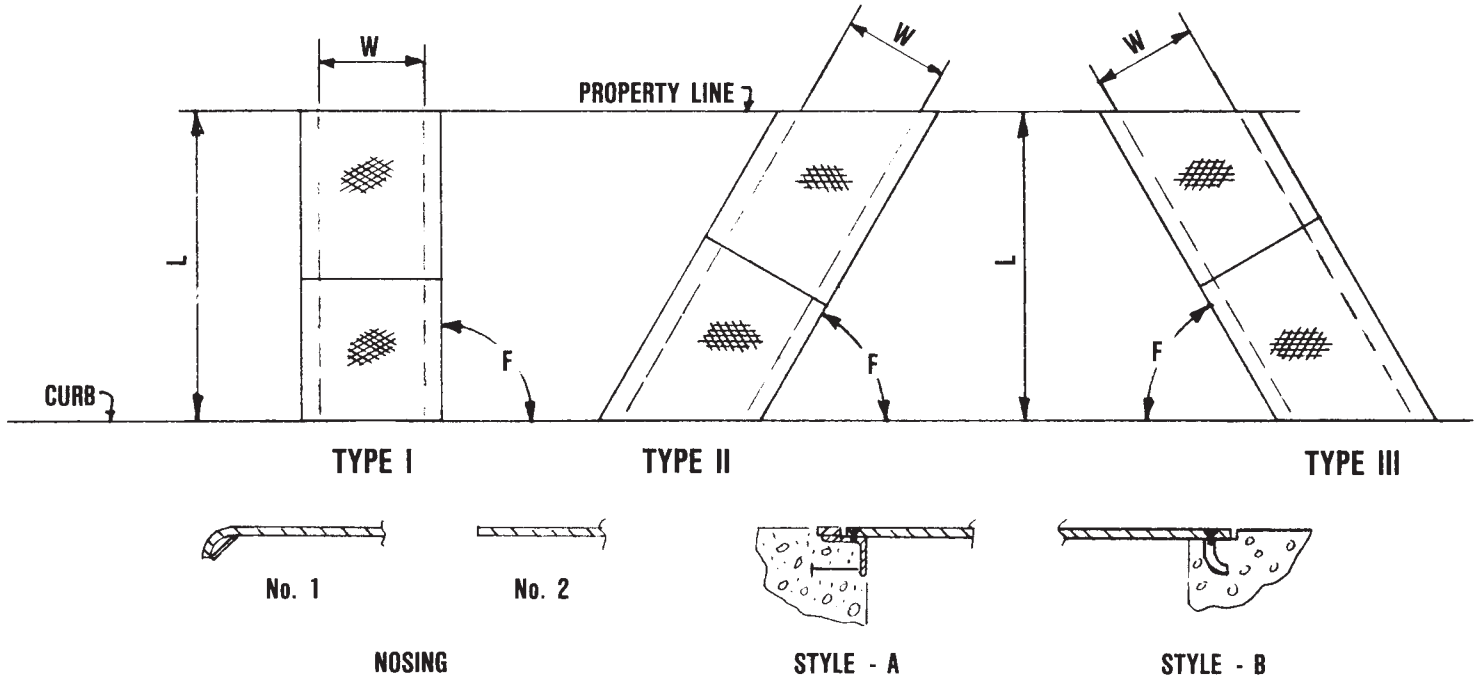

A-1094

Please furnish following information:

1. Agency and standard number if applicable
2. Type required (I, II, or III)
3. Style ("A" or "B")
4. With or without nosing (#1 or #2)
5. Checker plate cover thickness
6. Width of culvert "W" = clear opening
7. Distance from curb to property line ("L")
8. Angle -(F°)
9. Sketch when possible
10. Finish (galvanized or painted)

Note:

Covers can be supplied to following standards

1. City of Los Angeles — S-322 ALL GRIP
2. County of Riverside — #302
3. Other city and county standards



NAVY TYPE GRATES AND FRAMES

**CAST IRON DROP INLET GRATE
AND FRAME FOR CURB & GUTTER
ADJUSTABLE TO CURBING HEIGHT
FOR TRAFFIC**

PLATE NUMBER	CLEAR OPENING	OVERALL FLANGE	HEIGHT AT GUTTER	APPROX. WEIGHT
No. 10	17 x 23	32 x 32	6 1/4	610

Conforms to Navy PWO, San Diego, Dwg 535. Carefully Fitted Throughout. Raised Diamond Tread at Sidewalk Level. Painted: Bituminous Paint.

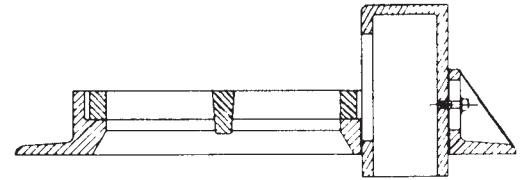
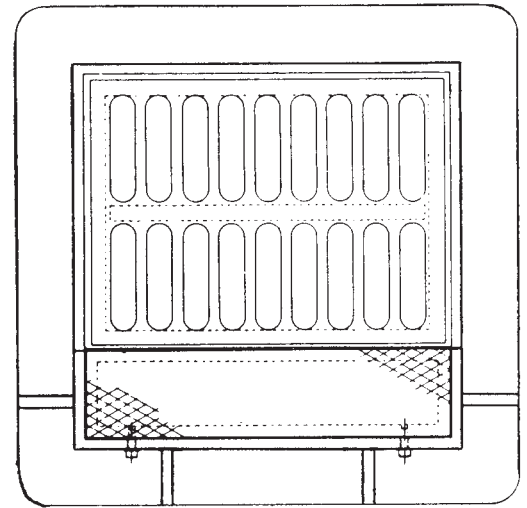

No. 10

C

**CURB INLET GUTTER
GRATE AND FRAME
NAVY STANDARD
FOR TRAFFIC**

PLATE NUMBER	CLEAR OPENING	OVERALL FLANGE	HEIGHT FRAME	APPROX. WEIGHT
No. 11	16 1/2 x 29 3/4	30 x 42	10 to 14	525

Grate Carefully Fitted to Frame. Painted: Bituminous Paint.

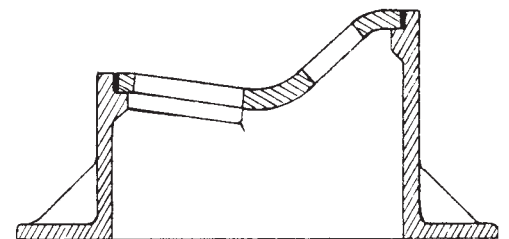
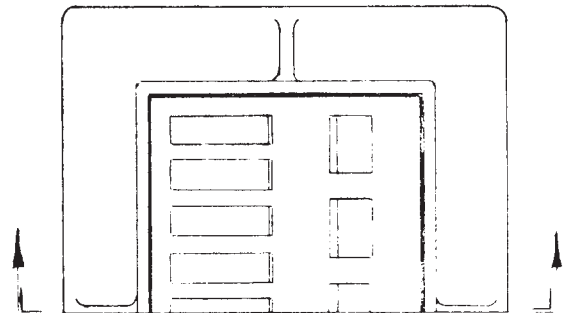

No. 11



NAVY TYPE GRATES AND FRAMES

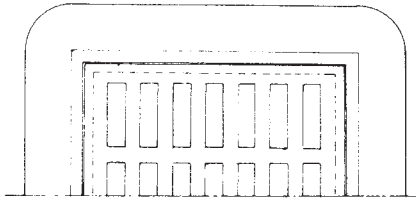

No. 14

NAVY SPEC. FOR TRAFFIC

PLATE NUMBER	CLEAR OPENING	OVERALL FLANGE	HEIGHT FRAME	APPROX. WEIGHT
No. 14	22 x 22	35 x 35	6	450

Grate Carefully Fitted to Frame. Painted: Bituminous Paint.

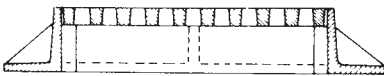
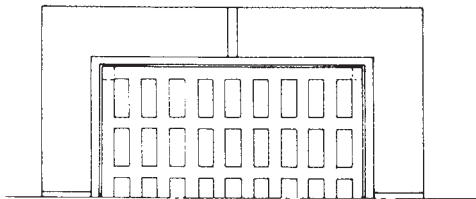

No. 15

NAVY SPEC. NON-TRAFFIC

PLATE NUMBER	CLEAR OPENING	OVERALL FLANGE	HEIGHT FRAME	APPROX. WEIGHT
No. 15	24 x 24	35 x 35	6	300

Grate Carefully Fitted to Frame. Painted: Bituminous Paint.

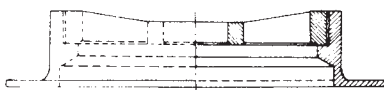
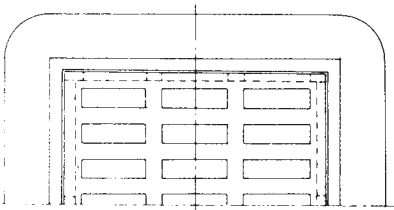

No. 16

NAVY SPEC. FOR TRAFFIC

PLATE NUMBER	CLEAR OPENING	OVERALL FLANGE	HEIGHT FRAME	APPROX. WEIGHT
No. 16	22 x 22	35 x 35	7	485

Concave Grate Carefully Fitted to Frame. Painted: Bituminous Paint.



CAST IRON GRATE AND FRAME

PLATE NUMBER	STRENGTH	CLEAR OPENING	OVERALL BASE	HEIGHT FRAME	APPROX. WEIGHT
A-1231	Non-Traffic	22 x 22	36 x 36	7	340
A-1232	Traffic	22 x 22	36 x 36	8	450
*A-1233	Non-Traffic	24 x 24	35 x 35	6	300

See Navy Grates and Frames Pages C-16 and C-17. Grate and Frame Carefully Fitted. Painted: Bituminous Paint.

*With Traffic Grate, Frame Height 8"

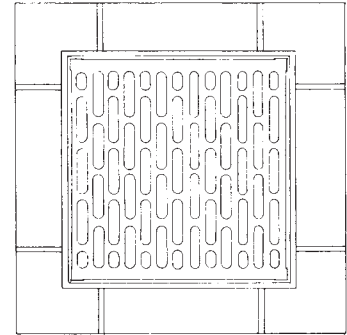

A-1230

CAST IRON COVER AND FRAME

PLATE NUMBER	STRENGTH	CLEAR OPENING	OVERALL BASE	HEIGHT FRAME	APPROX. WEIGHT
A-1234	Non-Traffic	22 x 22	36 x 36	7	420
A-1235	Traffic	22 x 22	36 x 36	8	500
*A-1236	Non-Traffic	24 x 24	35 x 35	6	325

Diamond Tread. Cover and Frame Carefully Fitted. Painted: Bituminous Paint.

*With Traffic Grate, Frame Height 8"

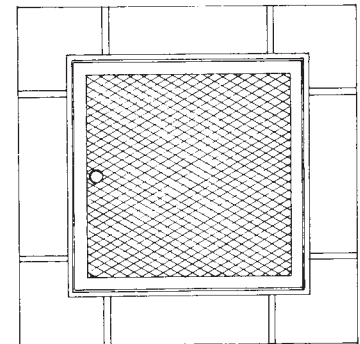

A-1234

**CAST IRON COVER AND FRAME
FOR STEAM BLOW-OFF TANKS
BOLTED DOWN COVER WITH GASKET**

PLATE NUMBER	STRENGTH	CLEAR OPENING	OVERALL BASE	HEIGHT FRAME	APPROX. WEIGHT
A-1237-B	Non-Traffic	22 x 22	36 x 36	7	430
A-1238-B	Traffic	22 x 22	36 x 36	8	480

Diamond Tread. Lettered Designation to Suit. Cover Bolted Down with Stainless Steel Studs. Composition or Lead Gasket. Hinged Ring Lift Handle. Painted: Bituminous Paint.

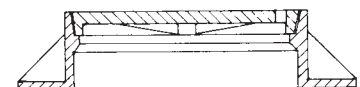
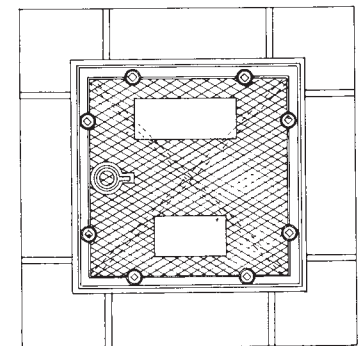

A-1237-B

C

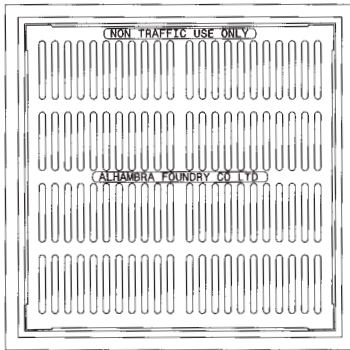

**A.D.A.
BICYCLE PROOF
A-2010 NON-TRAFFIC GRATES**

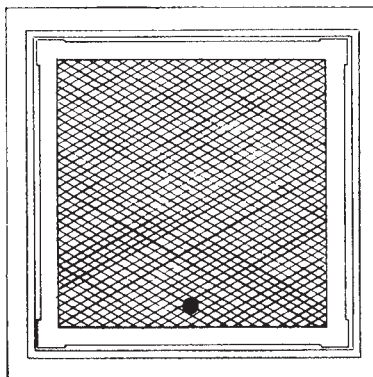
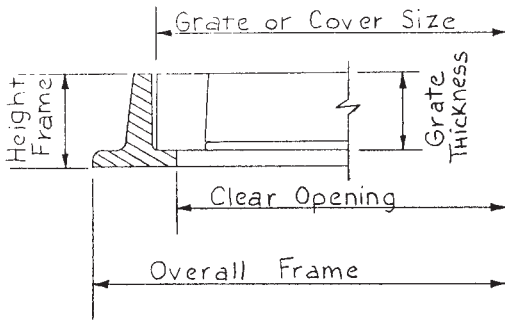

A-2015 NON-TRAFFIC COVERS

**NON-TRAFFIC CAST IRON GRATES OR
COVERS AND FRAMES
ADA GRATES
SPECIFY GRATE OR COVER SIZE
A-2010 GRATES AND FRAMES
A-2015 COVERS AND FRAMES**

GRATE OR COVER SIZE	CLEAR OPENING FRAME	OVERALL FRAME	HEIGHT FRAME	APPROX. SHIPPING WEIGHT
SQUARE				
6 x 6	5 x 5	8 x 8	1	7
8 x 8	7 x 7	10 x 10	1	12
10 x 10	9 x 9	12 x 12	1	22
12 x 12	11 x 11	14 x 14	1½	40
14 x 14	13 x 13	17 x 17	1½	49
16 x 16	15 x 15	18 x 18	1½	61
18 x 18	16 x 16	20 x 20	1½	65
20 x 20	18 x 18	22 x 22	1½	78
24 x 24	22 x 22	26 x 26	1½	91
26 x 26	24 x 24	28 x 28	1½	120
★ 32 x 32	30 x 30	35 x 35	2¾	252
★ 38 x 38	36 x 36	41 x 41	2¾	261
RECTANGULAR				
12 x 24	11 x 23	14 x 26	1½	62
18 x 24	17 x 23	20 x 26	1½	80
24 x 36*	22 x 34	27 x 38	1¾	170
24 x 48*	22 x 46	26 x 50	1½	210

* Grate or Cover in 2 Pieces.
Note: Give Size and Plate Number When Ordering.
All of Above Items Can Be Furnished with Lock Screws to Prevent Vandalism.

Painted: Bituminous Paint
Galvanized on Request

★ **NOTE: All Grates Except 32 x 32 and 38 x 38 comply to A.D.A. standards.**

★ — signifies more favorable stock and volume production



**TRAFFIC CAST IRON GRATES OR
COVERS AND FRAMES
WITH OR WITHOUT FRAMES
SPECIFY GRATE OR COVER SIZE
A-2012 GRATES AND FRAMES
A-2017 COVERS AND FRAMES**

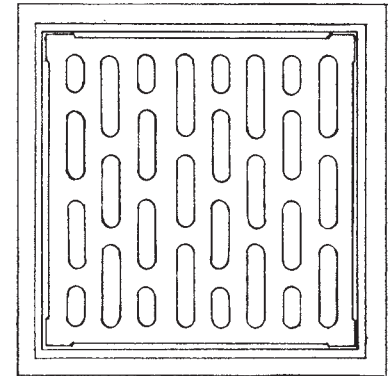

**BICYCLE PROOF
A-2012 TRAFFIC GRATES**

C

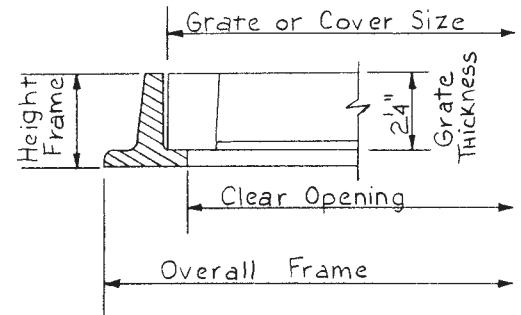

GRATE OR COVER SIZE	CLEAR OPENING	OVERALL FRAME	HEIGHT FRAME	APPROX. SHIPPING WEIGHT
SQUARE				
★ 12 x 12	10 x 10	15 x 15	2½	75
★ 14 x 14	12 x 12	17 x 17	2½	80
16 x 16	14 x 14	19 x 19	2½	105
18 x 18	16 x 16	21 x 21	2½	130
20 x 20	18 x 18	23 x 23	2¾	150
★ 24 x 24	22 x 22	27 x 27	2¾	200
★ 26 x 26	24 x 24	29 x 29	2¾	230
32 x 32	30 x 30	35 x 35	2¾	362
38 x 38	36 x 36	41 x 41	2¾	520
RECTANGULAR				
★ 12 x 24	11 x 23	15 x 27	2¾	140
★ 12 x 36*	11 x 35	15 x 39	2¾	196
18 x 24	16 x 22	21 x 27	2¾	188
24 x 36*	22 x 34	27 x 39	2¾	385
★ 24 x 48*	22 x 46	27 x 51	2¾	450
30 x 48*	27 x 45	32 x 51	2¾	530

* Grate or Cover in Two Pieces.
Note: Give Size and Plate Number When Ordering.
All of Above Items Can Be Furnished with Lock Screws to Prevent Vandalism.

Painted: Black Bituminous Paint
Galvanized on Request.

★ ALSO AVAILABLE WITH A.D.A. GRATES.

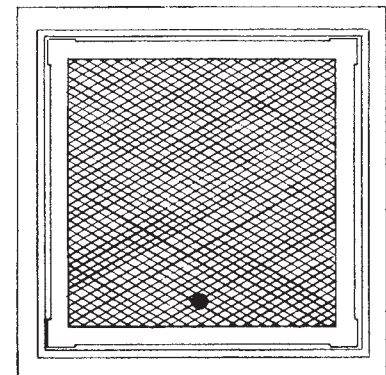

A-2017 TRAFFIC COVERS



A-2020 STANDARD GRATES

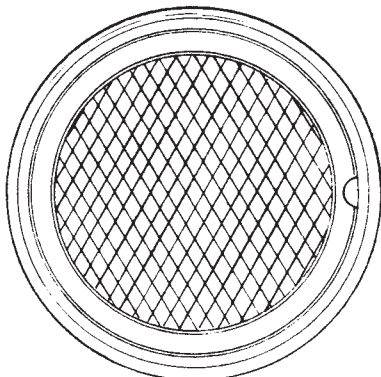

A-2025 STANDARD COVERS

**NON TRAFFIC A-2020 GRATE AND FRAME
OR A-2025 COVER AND FRAME**

WHEN ORDERING GIVE DIAMETER SIZE OF GRATE OR COVER

DIAMETER	CLEAR OPENING	FRAME DIAMETER	HEIGHT FRAME	APPROX. WEIGHT
5	4½	6⅝	⅞	5
6	5	7½	1	6
8	7	10	1	12
10	9	12	1	18
12	11	14	1½	38
14†	12¾	16	1½	46
16†	15	18	1½	48
18†	16¾	20	1½	55

Above are Ground Fit Only.
Refer to Series A-1260, Page A-1, for Larger Sizes.
† Grate Has Center Rib.

Painted Black, Galvanized on Request

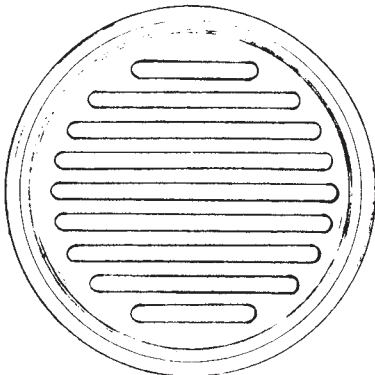

A-2022 TRAFFIC GRATES

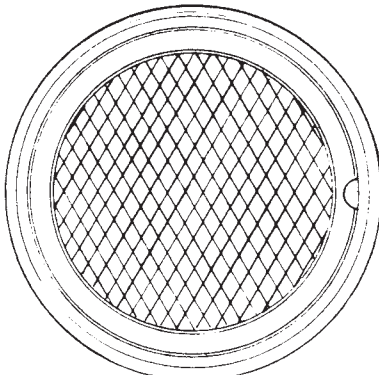

A-2027 TRAFFIC COVERS

**TRAFFIC WEIGHT A-2022 GRATE AND FRAME
OR A-2027 COVER AND FRAME**

WHEN ORDERING GIVE DIAMETER SIZE OF GRATE OR COVER

DIAMETER	CLEAR OPENING	FRAME DIAMETER	HEIGHT FRAME	APPROX. WEIGHT
6	4½	8¼	1½	10
8	6½	10	1½	18
10†	8	11½	1½	32
12†	11	14	1⅝	60
14	11¾	17	2½	85
16	14	19	2½	95
18†	16½	21	2½	108

Above are Ground Fit Only.
Refer to Series A-1250, Page A-1, for Larger Sizes.
† Grate Has Center Rib.
All of the Above Can Be Furnished with Lock Screws to Prevent Vandalism.

Painted Black, Galvanized on Request



**C. I. SAND TRAP FRAME
WITH COVER AND GRATE**

PLATE NUMBER	OVERALL COVERS	STRENGTH	HEIGHT FRAME	APPROX. WEIGHT
A-2014	24 x 48	Non-Traffic	1½	210
A-2018	24 x 48	Traffic	2¾	450

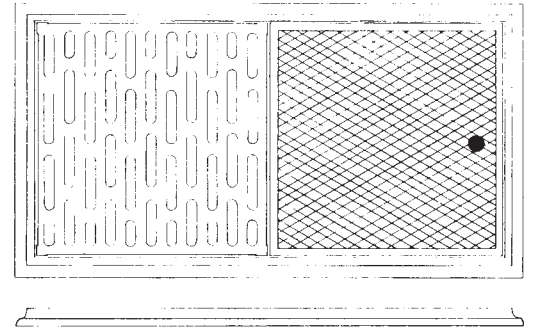

A-2014 NON-TRAFFIC

A-2018 TRAFFIC

**C. I. GARAGE SAND TRAP FRAME
WITH COVER AND GRATE
NON-TRAFFIC**

PLATE NUMBER	OVERALL GRATE & COVER	OVERALL FRAME	APPROX. WEIGHT
A-2040	19 x 36	21 x 38½	165

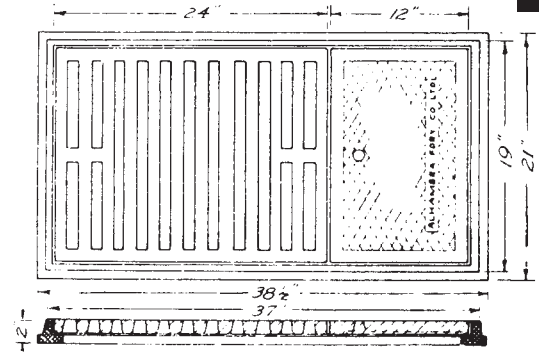

A-2040

**BRASS GRATE AND FRAME
NON-TRAFFIC**

SIZE GRATE	SIZE FRAME	HEIGHT FRAME	APPROX. WEIGHT
6 x 6	7 x 7	¾	5
8 x 8	9 x 9	¾	14
10 x 10	11 x 11	¾	16
12 x 12	13 x 13	¾	18
16 x 16	17 x 17	7/8	34
18 x 18	19 x 19	7/8	40
12 x 20	13 x 21	7/8	40
18 x 24	19 x 25	7/8	58

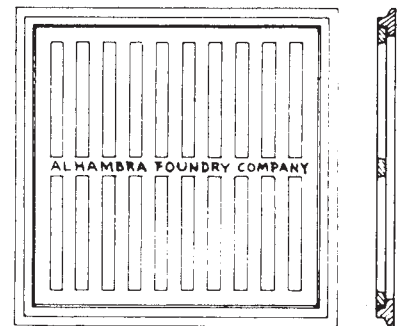

A-2011

All Brass Grates and Frames Belt Sand Finished.



C. I. SECTIONAL TRENCH GRATES OR SOLID COVERS WITH OR WITHOUT FRAMES

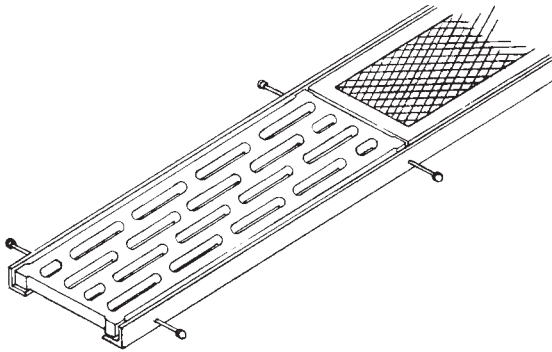

**A-2420 OR A-2430
NARROW SLOTS SEE A-2401 PAGE C-29**

**GRATE OR COVER WITH STEEL ANGLE FRAME
NON-TRAFFIC**

A-2401 GRATE ONLY 24" LONG SECTIONS
 A-2420 GRATE WITH ANGLE FRAME
 A-2410 COVER ONLY 24" LONG SECTIONS
 A-2430 COVER WITH ANGLE FRAME
 STANDARD WIDTHS 6-8-10-12-14-18.

APPROX. WTS. PER LINEAL FOOT — GRATES & COVERS

WIDTH	6"	8"	10"	12"	14"	18"
GRATE	11#	14#	17#	20#	23#	30#
COVER	12#	16#	19#	21#	30#	35#

Weight Per Foot Angle Frame=4#.

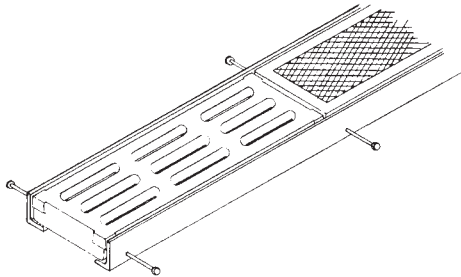

**A-2422 OR A-2432
NARROW SLOTS SEE A-2405 PAGE C-29**

**GRATE OR COVER WITH STEEL ANGLE FRAME
FOR TRAFFIC**

A-2404 GRATE ONLY 24" LONG SECTIONS
 A-2422 GRATE WITH ANGLE FRAME
 A-2412 COVER ONLY 24" LONG SECTIONS
 A-2432 COVER WITH ANGLE FRAME
 STANDARD WIDTHS 6-8-10-12-14-18.

APPROX. WTS. PER LINEAL FOOT — GRATES AND COVERS

WIDTH	6"	8"	10"	12"	14"	18"
GRATE	20#	28#	35#	44#	50#	60#
COVER	28#	33#	37#	44#	71#	75#

Weight Per Foot Angle Frame=7#.
 For Widths Over 18" See Page C-24

**GRATE OR COVER WITH CAST IRON BOLTED FRAME
NON-TRAFFIC**

A-2401 GRATE ONLY 24" LONG SECTIONS
 A-2424 GRATE WITH C.I. FRAME
 A-2410 COVER ONLY 24" LONG SECTIONS
 A-2426 COVER WITH C. I. FRAME

APPROX. WTS. PER LINEAL FOOT — INCLUDING FRAMES

WIDTH	6"	8"	10"	12"	14"	18"
GRATE	22#	25#	28#	31#	34#	30#
COVER	23#	27#	30#	32#	41#	46#

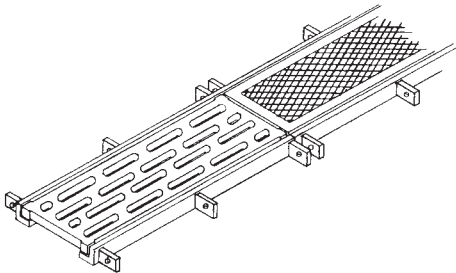

A-2424 OR A-2426

**GRATE OR COVER WITH CAST IRON BOLTED FRAME
FOR TRAFFIC**

A-2404 GRATE ONLY 24" LONG SECTIONS
 A-2434 GRATE WITH C.I. FRAME
 A-2412 COVER ONLY 24" LONG SECTIONS
 A-2436 COVER WITH C.I. FRAME

APPROX. WTS. PER LINEAL FOOT — INCLUDING FRAME

WIDTH	6"	8"	10"	12"	14"	18"
GRATE	42#	50#	57#	67#	73#	60#
COVER	50#	55#	59#	67#	94#	120#

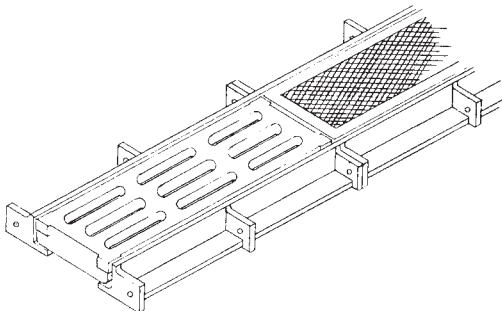

A-2434 OR A-2436



**C. I. SECTIONAL TRENCH GRATES
WITH OR WITHOUT FRAMES**

*Not recommended for use in high speed areas unless bolted to frame.

**GRATE
FOR HEAVY TRAFFIC**

A-2402 GRATE ONLY 24" LONG SECTIONS
A-2422 GRATE WITH ANGLE FRAME

24" x 24"

GRATE — WEIGHT PER LINEAL FOOT=84 LBS.
FRAME — WEIGHT PER FOOT=7 LBS.

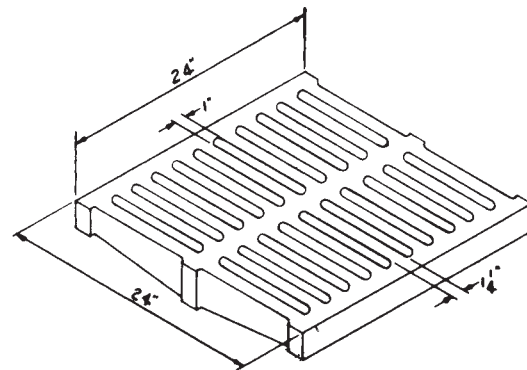

**GRATE
FOR HEAVY TRAFFIC**

A-2402 GRATE ONLY 24" LONG SECTIONS
A-2422 GRATE WITH ANGLE FRAME
A-2434 GRATE WITH C.I. FRAME

24" x 26"

GRATE — WEIGHT PER SECTION=216 LBS.

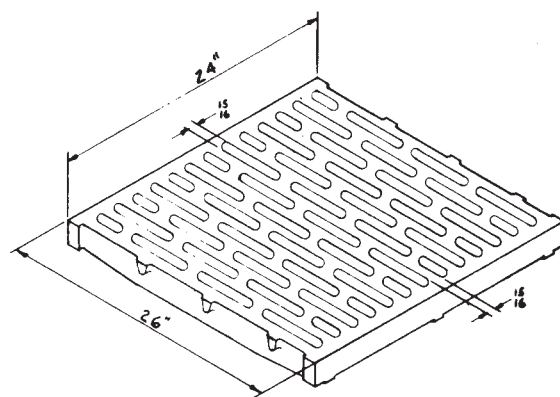

C

**GRATE
FOR HEAVY TRAFFIC**

A-2402 GRATE ONLY 24" LONG SECTIONS
A-2422 GRATE WITH ANGLE FRAME
A-2434 GRATE WITH C.I. FRAME

24" x 38"

GRATE — WEIGHT PER SECTION=340 LBS.

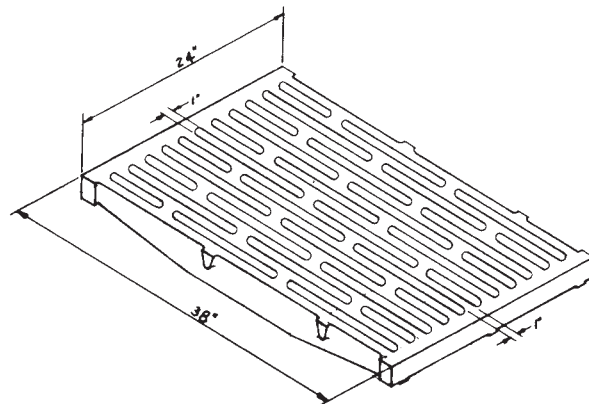

**GRATE
FOR TRAFFIC AND AIRCRAFT**

A-2402 GRATE ONLY 24" LONG SECTIONS
A-2422 GRATE WITH ANGLE FRAME

24" x 26 3/4"

GRATE — WEIGHT PER SECTION=176 LBS.

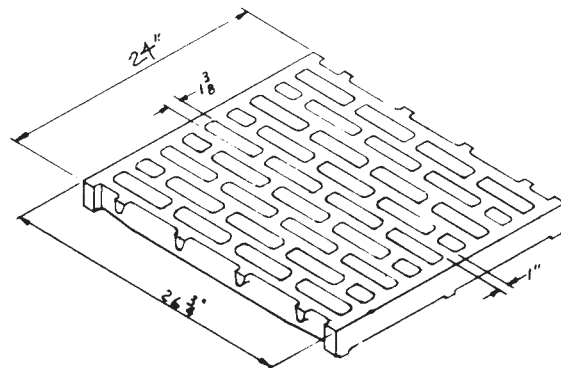



**FORMED STEEL TROUGH
FOR GRATE OR SOLID COVER
ELIMINATES FORMING FOR CONCRETE
TROUGH FURNISHED IN 10 FT. LENGTHS
NON-TRAFFIC**

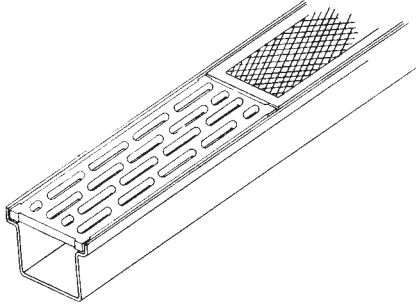

**A-2440 OR A-2442
NARROW SLOTS SEE A-2401 PAGE C-29**

WIDTH GRATE	WIDTH TRENCH	DEPTH TRENCH	LENGTH GRATE	APPROX. WEIGHT PER FOOT GRATE AND TROUGH	APPROX. WEIGHT PER FOOT COVER AND TROUGH
6	4	6	24	22	23
8	6	6	24	26	28½
10	8	6	24	31	33
12	10	6	24	35	35½
14	12	6	24	39	46½

A-2440 GRATE WITH STEEL TROUGH
A-2442 COVER WITH STEEL TROUGH
Grate or Cover is Cast in 2'0" Lengths and is Supplied for Required Lengths of Trough. Finish: Bituminous Paint, or Galvanized.
Contractors' Note: Spreaders ½" Wider Than Grate or Cover on 18" Centers Placed in Frame Seat Before Concrete is Poured, Holds Frame in Position.

FOR TRAFFIC

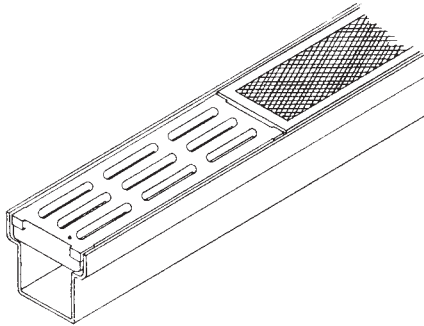

**A-2446 OR A-2448
NARROW SLOTS SEE A-2405 PAGE C-29**

WIDTH GRATE	WIDTH TRENCH	DEPTH TRENCH	LENGTH GRATE	APPROX. WEIGHT PER FOOT GRATE AND TROUGH	APPROX. WEIGHT PER FOOT COVER AND TROUGH
6	4	8	24	34	42
8	6	8	24	43	47½
10	8	8	24	51	53
12	10	8	24	61	60½
14	12	8	24	69	90

A-2446 GRATE WITH STEEL TROUGH
A-2448 COVER WITH STEEL TROUGH
Grate is Used to Drain Wide Surface Areas such as Loading Ramps, Highway Underpass, Service Station Areas and many other areas. Cover is used for Utility Lines across Roadways and Working Areas with Quick Access to Trench for Removal or Addition of Lines.
Contractors' Note: Spreaders ½" Wider than Grate or Cover Placed at 18" Centers on Seat of Frame Before Pouring Concrete, Holds Frame in Position. Finish: Bituminous Paint or Galvanized.

**GRATE AND FRAME
FOR TRAFFIC**

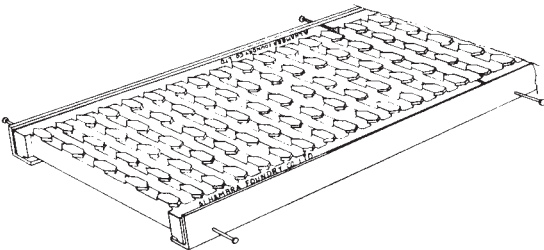

A-2423

A-2403 GRATE ONLY 24" LONG SECTIONS
A-2423 GRATE WITH ANGLE FRAME
STANDARD WIDTHS 10-12-14.

ANGLES ARE FURNISHED WITH NELSON STUD ANCHORS.
NOTE: USE SPREADERS ½" WIDER THAN GRATE AT 18" CENTERS ON STEEL ANGLE FRAME BEFORE POURING CONCRETE.
Raised Diamond Tread Designed to Direct Flow for Greater Intake.

A-2403 - GRATE ONLY - APPROX. WTS PER LINEAL FOOT			
WIDTH	10"	12"	14"
WT./FT.	38#	45#	53#

Wt. Per Foot - Angle Frame for A-2423=7 Lbs.



CAST IRON DRAINAGE TROUGHS
Used in Areas That Require
Continuous Grates or Solid Covers.
NON-TRAFFIC

TABLE OF DIMENSIONS

CAT. NO.	DESCRIPTION	A	B	C	D	E	F	G	APPROX. WT. PER FT.
A-2421	Grate with Trough	6	6¾	1	6	4½	7⅛	8	36
A-2431	Cover with Trough	6	6¾	1	6	4½	7⅛	8	41

4" Inside Caulk. Outlets are Furnished on Bottom of Drain.

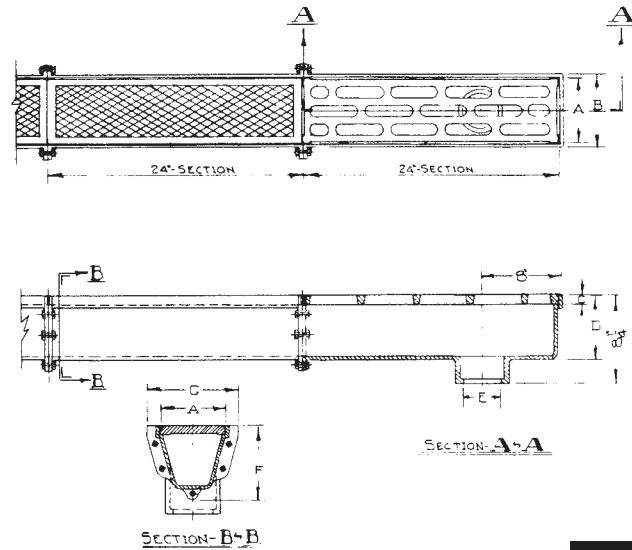

A-2421 OR A-2431
NARROW SLOTS SEE A-2401 BELOW



NARROW SLOT TRENCH GRATES
Used in Pedestrian Areas
Malls and Entrances
NON-TRAFFIC

NOTE: Non-Traffic Trench Grates with Narrow Spaces for Use in Pedestrian Areas, Malls and Entrances. Bolting Recess is Provided for Bolting When Required. Can Be Used with Steel Angle Frame, Trough or Cast Iron Frame.

A-2401 - APPROX. WTS PER LINEAL FOOT				
A	WIDTH	B	GRATE	W/FRAME
6"		4¼"	8#	12#
8"		6¼"	10	14
10"		8¼"	12	16
12"		10¼"	14	18
14"		12¼"	16	20

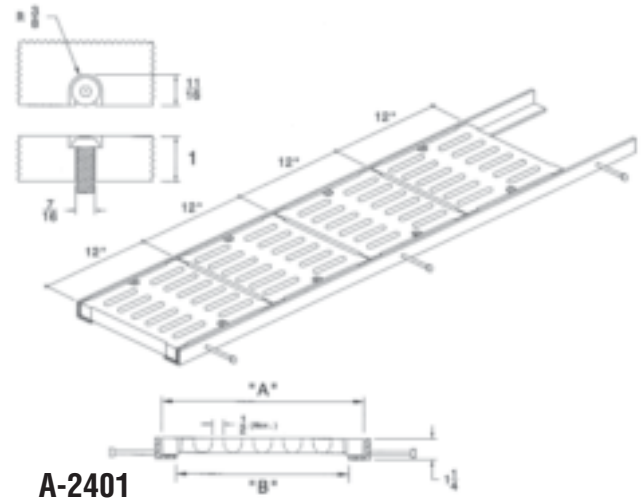

A-2401

NARROW SLOT TRENCH GRATES
TRAFFIC

NOTE: Traffic Trench Grates with Narrow Spaces For Use in Special Areas Where There is Both Vehicular and Pedestrian Traffic (Wheel Chairs, Hand Carts, Airport Areas).

A-2405 - APPROX. WTS PER LINEAL FOOT				
A	WIDTH	B	GRATE	W/FRAME
6"		3¾"	20#	27#
8"		5¾"	28	35
10"		7¾"	35	42
12"		9¾"	44	51
14"		11¾"	50	57

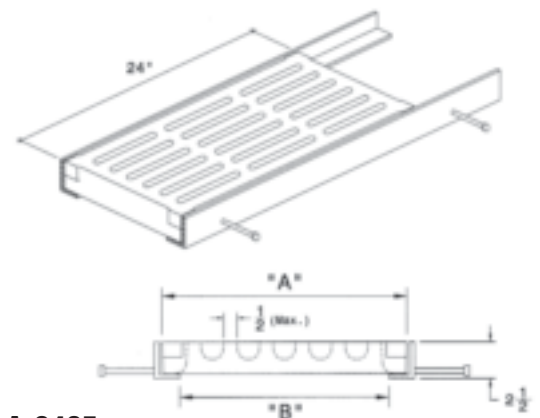

A-2405

NOTE: All "Narrow Slot" Grates Comply with the American Disabilities Act.



GRATE AND FRAME TO FIT HUB OF LARGE CLAY PIPE FOR DRY WELLS FOR TRAFFIC

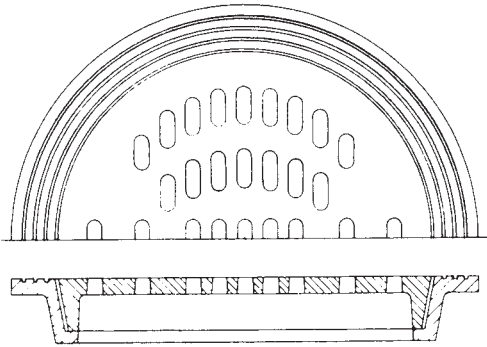

A-2220

PLATE NUMBER	CLAY PIPE	APPROX. WEIGHT
A-2221	15	160
A-2222	18	220
A-2223	21	280
A-2224	24	365

Frame Flange Entirely Shields Pipe.

GRATE TO FIT STANDARD CLAY PIPE HUB FOR TRAFFIC

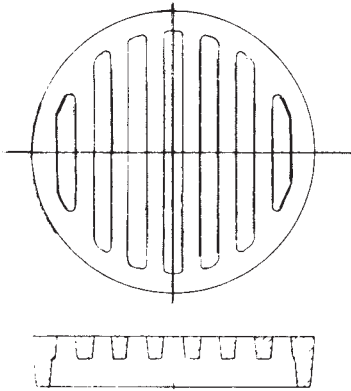

A-2230

PLATE NUMBER	PIPE SIZE	DEPTH	GRATE DIAMETER	APPROX. WEIGHT
★ ★ A-2232	4	2	5 ⁷ / ₈	7
★ A-2233	6	2 ¹ / ₂	8 ¹ / ₂	15
A-2234	7	2 ⁹ / ₁₆	9 ¹ / ₂	17
★ A-2235	8	2 ⁵ / ₈	10 ¹ / ₂	20
★ A-2236	10	2 ⁵ / ₈	13 ³ / ₄	30
★ A-2237	12	2 ¹ / ₂	15 ¹ / ₄	45
A-2238	14	2 ¹ / ₂	17 ⁵ / ₈	48
A-2239	15	2 ³ / ₄	19	55
A-2239 ¹ / ₂	18	2 ⁷ / ₈	22 ¹ / ₂	70
A-2240	24	3 ⁵ / ₈	29 ¹ / ₂	180

GRATE & FRAME TO FIT CORRUGATED METAL PIPE RISER NON-TRAFFIC

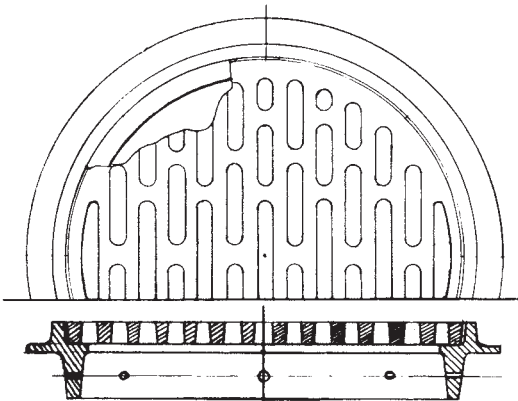

A-2250

PLATE NUMBER	PIPE SIZE	APPROX. WEIGHT
A-2251	24	120
A-2252	18	110

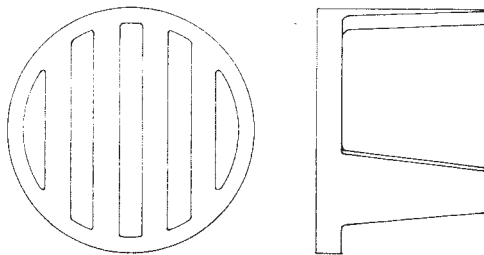

A-329

GRATE TO FIT C.I. SOIL PIPE HUB
Pipe Sizes: 2, 3, 4, 5, 6, 8 and 10

★ — signifies more favorable stock and volume production

SECTION

D



**MISC.
ENGINEERING
CONSTRUCTION
CASTINGS
and
HARDWARE**

D

***Flushing Valves, Sewage Disposal
Castings and Handrails, all types***

Flushing, Shear and Flap Valves	Sidewalk Valve Frames with Hinged Covers
Pressure Relief Valves	Service Station Fill Line Covers and Frames
Sewage Disposal Casting	Wheel Guards
Subdrain Gate Boxes	Pipe Rail
Stop Log Grooves	Guard Rail
Guy Wire Anchorage	Bridge Rail
Valve Box Caps	
C.I. Valve Extension Boxes	



FLAP GATE VALVE

PLATE NUMBER	SIZE OPENING	APPROX. WEIGHT
A-3650	6	11
A-3650	8	20
A-3650	12	35

Cast Iron Gate with Links and Corrosion-Resistant Steel Bolts. Seats are Ground.

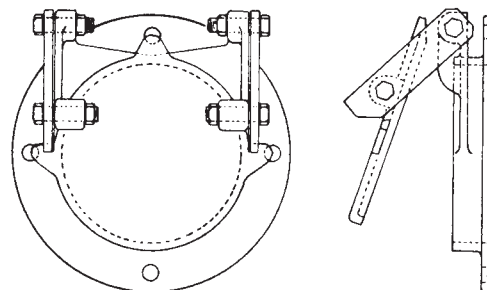

A-3650

**CAST IRON MANHOLE TRAP CASTING
FOR FORMING A WATER SEAL IN MANHOLE TO SEAL
OFF GASES IN SEWER LINES ENTERING MANHOLE**

PLATE NUMBER	LINE SIZE	LENGTH OVERALL	DEPTH SEAL	APPROX. WEIGHT
A-4011	8	21	1½	50
A-4012	10	24	1½	60
A-4013	12	28	1½	75

Painted: Bituminous Paint. Conforms to L.A. County Dwg. S-18.

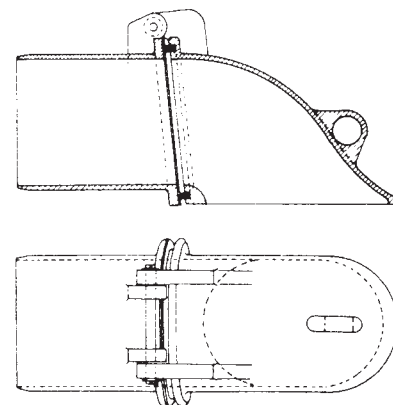

D

A-4010

**A-3631 — PRESSURE RELIEF VALVE
BRONZE COVER CAST IRON BODY
BRONZE BODY IF SPECIFIED**

4" Diameter Pipe — "A" Dimension
Varies 9" to 24" in 3" increments

Pressure relief valves are for placing in the bottom of concrete tanks to keep empty tanks from floating when there is an excess of ground-water underneath and around them.

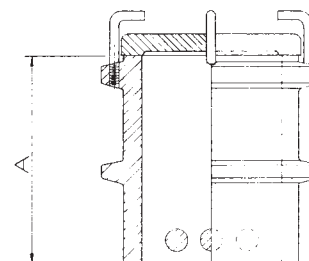

A-3631

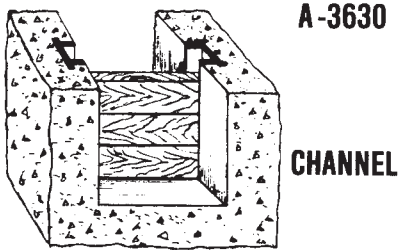

CAST IRON STOP LOG GROOVES
ENDS GROUND SQUARE
LUGS ON 12" CENTERS

Cast Iron Stop Log and Stop Plate Grooves are used for a Number of Purposes in Sewage Disposal Plants.

TYPE	X	Y	PATTERN LENGTH
#1	1/2	1 1/8	36
#1	5/8	1	36
#1	1	1 1/8	36
#1	2	1 3/4	36
#2	1 1/4	2	36
#2	1 1/2	1	36
#3	2	2 1/2	36
#4	1	2	36
#4	1 1/2	2	36

TYPE 1.

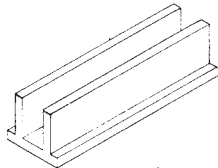
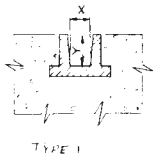

TYPE 2.

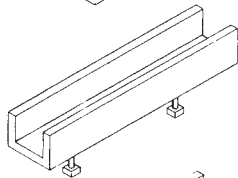
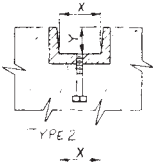

TYPE 3.

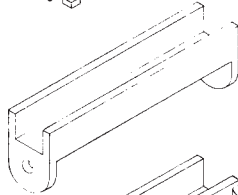
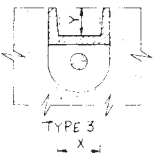

TYPE 4.

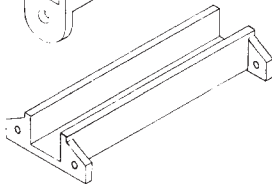
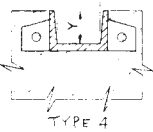

TYPE 4 — MODIFIED
(Corner Assembly)

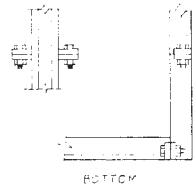

When Ordering Please Furnish Following:

1. Catalog Number
2. Groove Type
3. "X" and "Y" Dimensions
4. Detailed Sketch Showing Inside Height and Width of Channel.

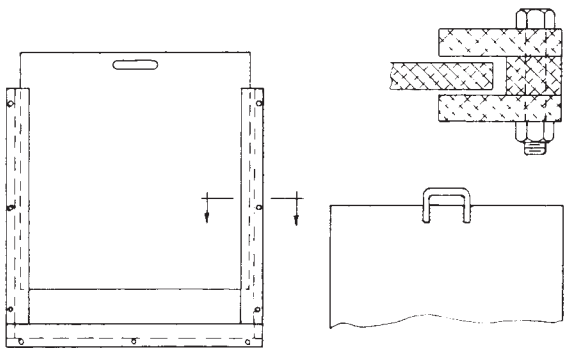

SLOT OR WELDED HANDLE OPTIONAL

FABRICATED ALUMINUM OR
STEEL GROOVES AVAILABLE
ALUMINUM OR STEEL PLATE ALSO SUPPLIED



**CAST IRON SUBDRAIN GATE BOX
BOLTED COVER SEALED WITH NEOPRENE GASKET**

PLATE NUMBER	INSIDE DIMENSIONS	COVER SIZE	APPROX. WEIGHT
A-3655	12 x 18 x 10	16½ x 22½ x ½	170

Cover Bolted to Box with Stainless Steel Bolts. Two inch Cast Iron Drain Plug. Conforms to U.S. Army Corps of Engineers and L.A. Co. Flood Control Dist. Specifications. Flap Valves and Fittings Not Included. See A-3650 for Flap Gate and A-3658 for Adaptor.

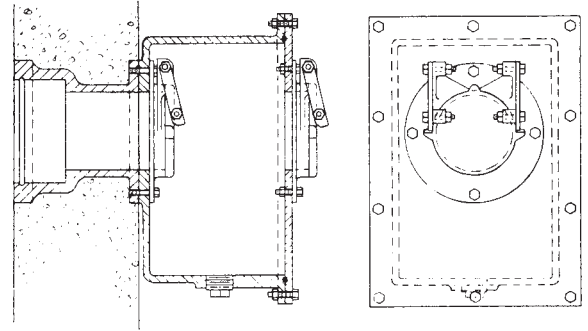

A-3655

**CAST IRON SUBDRAIN OUTLET GATE BOX
WITH BOLTED COVER**

PLATE NUMBER	INSIDE DIMENSIONS	COVER SIZE	APPROX. WEIGHT
A-3656	11¼ x 12 x 8½	10 x 11¼	110

Cover Bolted to Box with Stainless Steel Bolts. Flap Valves and Fittings Not Included. See A-3650 for flap Gate and A-3658 for Adaptor. Conforms to U.S. Corps of Engineer Stds.

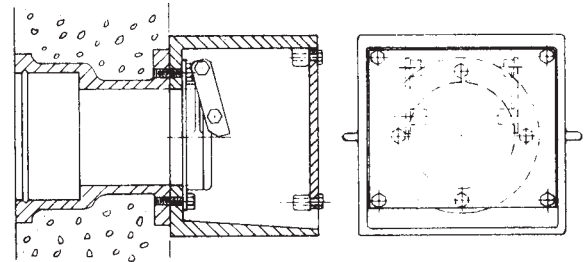

A-3656

D

**SPECIAL BELL AND FLANGE ADAPTOR
FOR CAST IRON SUBDRAIN BOX**

PLATE NUMBER	SIZE OUTLET	NUMBER HOLES	SIZE HOLES	LENGTH	APPROX. WEIGHT
A-3658	6	4	½	10	70
A-3659	6	4	½	12	75

See Plate A-3650, Page D-1, for Flap Gate.
Standard Length 10" Long. Other Lengths to Order.

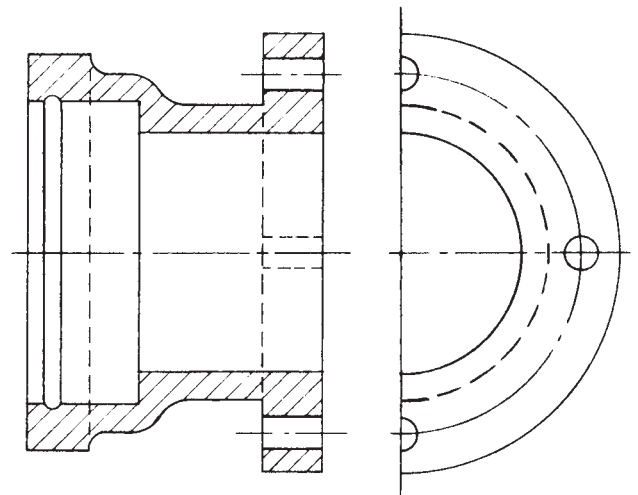

A-3658

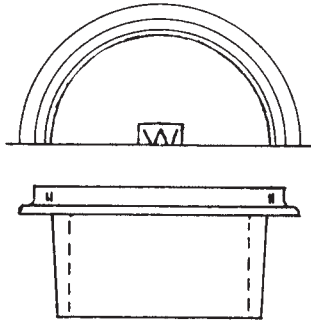

A-2980

**VALVE BOX FRAME WITH SEPARATE COVER
FOR TRAFFIC**

PLATE NUMBER	EXTENSION SIZE	APPROX. WEIGHT	PLATE NUMBER	EXTENSION SIZE	APPROX. WEIGHT
★ A-2984	4	10	A-2988	8	24
★ A-2986	6	15	A-2989	12	45

Nominal Size is Size of Pipe Used as an Extension. Cover Designated "W" or "G" to Suit. Painted: Bituminous Paint.

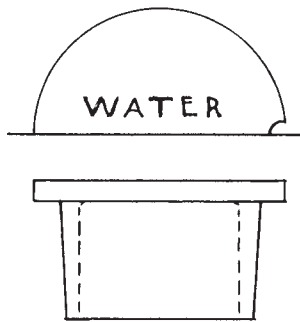

A-29600

**VALVE BOX CAP
FOR TRAFFIC — LONG BODY**

PLATE NUMBER	EXTENSION SIZE	APPROX. WEIGHT	PLATE NUMBER	EXTENSION SIZE	APPROX. WEIGHT
A-29602	2	1	A-29607	7	27
A-29603	3	4	★ A-29608	8	35
★ A-29604	4	7	A-29610	10	41
A-29605	5	50	★ A-29612	12	56
★ A-29606	6	20			

Nominal Size is Size of Pipe Used as an Extension. Cover Designated "Water" or "Gas" to Suit. Painted: Bituminous Paint.

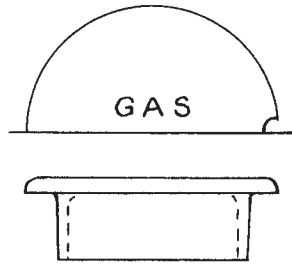

A-29500

**VALVE BOX CAP
NON-TRAFFIC — SHORT BODY**

PLATE NUMBER	EXTENSION SIZE	APPROX. WEIGHT	PLATE NUMBER	EXTENSION SIZE	APPROX. WEIGHT
A-29502	2	1	★ A-29506	6	9
A-29503	3	4	★ A-29508	8	13
★ A-29504	4	4	A-29510	10	20
A-29505	5	7	A-29512	12	56

Nominal Size is Size of Pipe Used as an Extension. Cover Designated "Water" or "Gas" to Suit. Painted: Bituminous Paint.

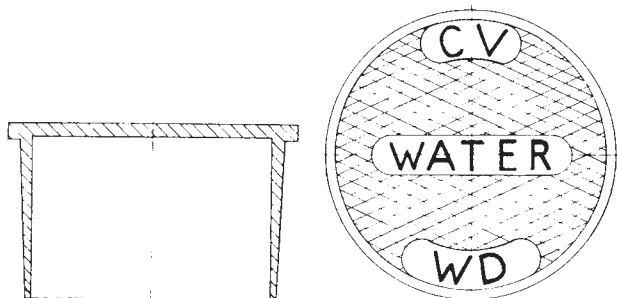

A-29625

**VALVE BOX CAP
FOR TRAFFIC**

PLATE NUMBER	EXTENSION SIZE	DEPTH SKIRT	OVERALL FLANGE	APPROX. WEIGHT
A-29625	10	6½	11	40

Extension Size: Refers to Size of Pipe from Valve to Road Surface. Cover Designated "Water" or "Gas" to Suit. Other Lettering as Required on Quantity Orders with no Extra Charge. Painted: Bituminous Paint.

★ — signifies more favorable stock and volume production



CAST IRON VALVE EXTENSION BOXES

STATE VALVE SIZE AND DEPTH OF TRENCH WHEN ORDERING
COVERS WILL BE FURNISHED DESIGNATING "WATER"
UNLESS OTHERWISE STATED

**A-3000 — 5 1/4" DIAMETER SHAFT, SCREW
ADJUSTMENT**

Depth Trench	30	36	42	48	54	60
--------------	----	----	----	----	----	----

PART NUMBER	WEIGHT
No. 1—Cover	13
No. 2—Top Section	38
No. 3—Center Section	27
No. 4—Bell	40
No. 5—Extension	23

For Up To 18" Valves.

PARTS REQUIRED

VALVE SIZE	BOTTOM OF BASE TO BOTTOM OF TRENCH	DEPTH OF BOX	PARTS REQUIRED
★ 3	10	26	1-2-4
★ 4	12	24	1-2-4
★ 6	15	21	1-2-4
★ 4	12	36	1-2-3-4
★ 6	15	33	1-2-3-4
★ 8	20	28	1-2-3-4
★ 12	29	19	1-2-4
★ 4	12	48	1-2-3-4-5
★ 6	15	45	1-2-3-4-5
★ 8	20	40	1-2-3-4
★ 12	29	31	1-2-3-4
★ 16	40	20	1-2-4

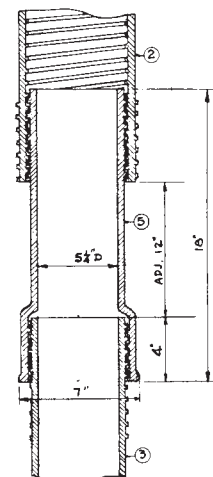
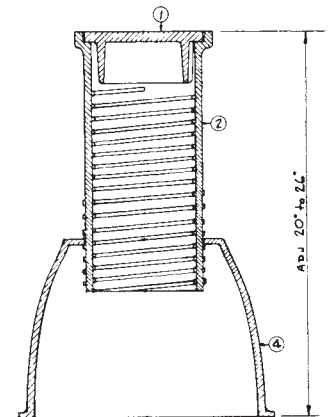
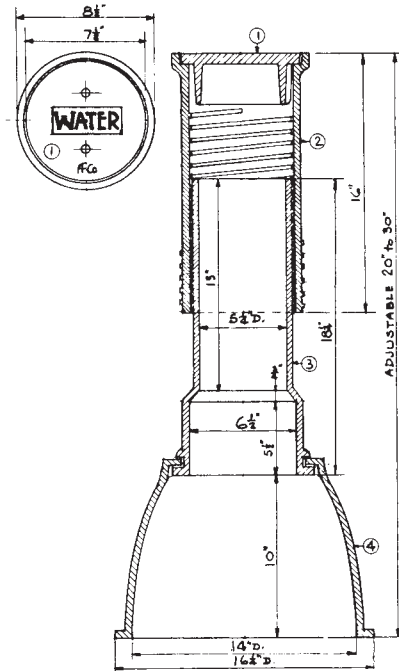

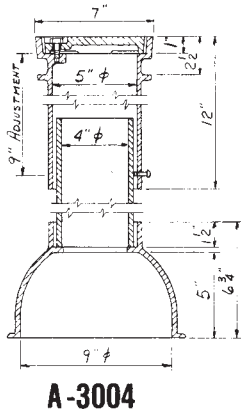

CAST IRON VALVE EXTENSION BOXES

STATE VALVE SIZE AND DEPTH OF TRENCH WHEN ORDERING
COVERS WILL BE FURNISHED DESIGNATING "WATER"
UNLESS OTHERWISE STATED

SLIP ADJUSTMENT TYPE WITH SET SCREW LOCK

★ A-3004—For up to 6" Valves			
Trench Depth Up To	36"	48"	60"
Approx. Weight	45 Lbs.	50 Lbs.	60 Lbs.

SLIP ADJUSTMENT TYPE WITH LOOSE COVER

★ A-3005—For up to 16" Valves		
Trench Depth Up To	35"	60"
Approx. Weight	90 Lbs.	150 Lbs.

★ A-3007—For up to 24" Valves		
Trench Depth Up To	36"	60"
Approx. Weight	120 Lbs.	185 Lbs.

**A-3009—For 4" TO 12" VALVES
GOVERNMENT TYPE
TWO PIECE VALVE BOX 5/8" SHAFT SLIP TYPE**

★ A-3009—For 4" to 12" Valves	
Trench Depth Up To	36"
Approx. Weight	85 Lbs.

★ **A-3008 EXTENSION OPERATING HANDLE**
* 5 FEET LONG FOR 2 INCH
SQUARE OPERATING NUT
Weight: 20 Lbs.

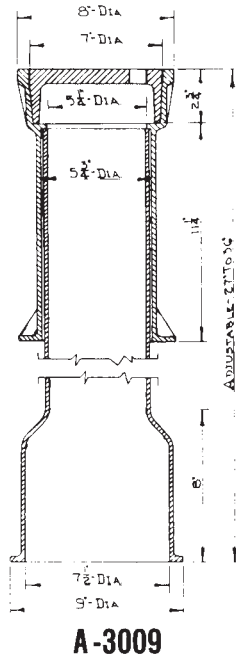
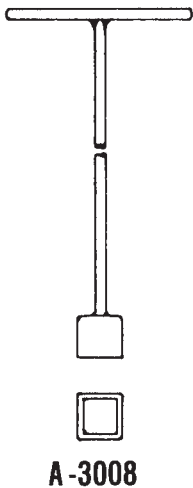
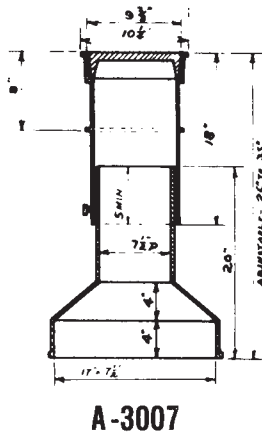
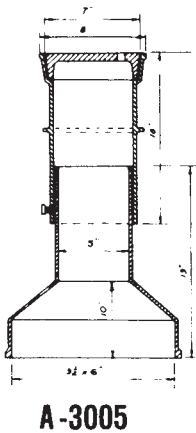

* Longer handles made to order

★ — signifies more favorable stock and volume production



**NON-TRAFFIC HINGED COVER WITH FRAME
FOR VALVE OR CLEANOUT ACCESS**

PLATE NUMBER	CLEAR OPENING	OVERALL FLANGE	DEPTH SKIRT	APPROX. WEIGHT
★ A-2281	6 x 6	8½ x 8½	4	8
★ A-2282	8 x 8	10½ x 10½	4	12
★ A-2283	12 x 12	14½ x 14½	4	22
★ A-2291	6 x 6	8½ x 8½	1½	6
★ A-2292	8 x 8	10½ x 10½	1½	9
★ A-2293	12 x 12	14½ x 14½	1½	15

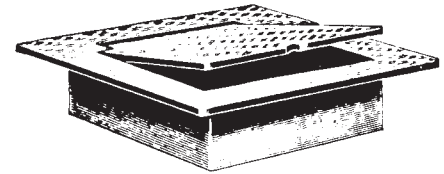

A-2280

Painted: Bituminous Paint.

**ROUND NON-TRAFFIC HINGED COVER WITH FRAME
FOR VALVE OR CLEANOUT ACCESS**

PLATE NUMBER	CLEAR OPENING	DIAMETER TOP	HEIGHT FRAME	APPROX. WEIGHT
A-2301	6	9	2	10

Painted: Bituminous Paint.

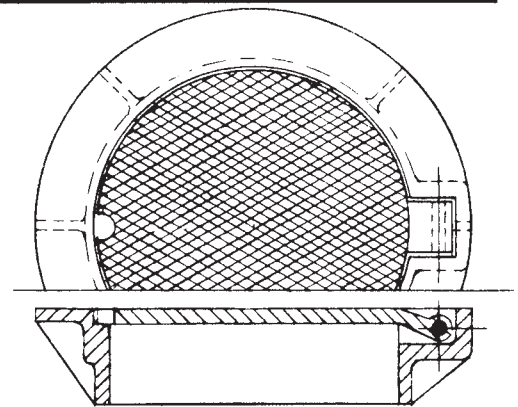

A-2301

D

**BRASS FIRE HOSE BASEMENT INLET
FINISHED BRASS TOP**

PLATE NUMBER	CLEAR OPENING	OVERALL FLANGE	HEIGHT FRAME	APPROX. WEIGHT
A-371	8	10 x 10	1¼	15

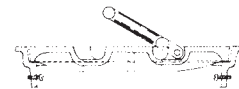
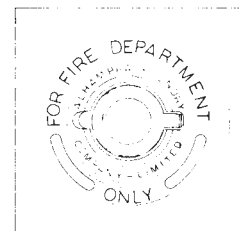

A-371

**HINGED, LOCKING COVER WITH FRAME
FOR VALVES AND FILLING LINES
SLOW MOVING TRAFFIC**

PLATE NUMBER	CLEAR OPENING	OVERALL TOP	HEIGHT FRAME	APPROX. WEIGHT
A-391	12½ x 12½	18½ x 18½	4	90

Diamond Tread. Designed for Service Station Areas.

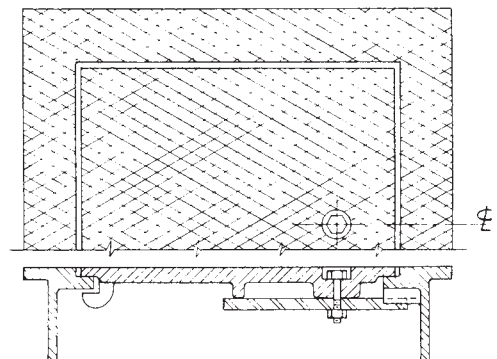

A-391

★ — signifies more favorable stock and volume production

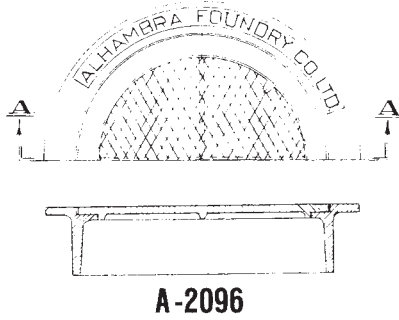

**Service Station Fill Line Covers and Frames
FOR USE OVER UNDERGROUND CONNECTIONS
SLOW MOVING TRAFFIC**

CAST IRON ROUND COVER AND FRAME

PLATE NUMBER	COVER SIZE	OVERALL TOP	HEIGHT FRAME	APPROX. WEIGHT
★ A-2096	8	10	3¼	14
★ A-2097	10	12	3¼	18
★ A-2098*	12	14	3¼	22

If 25 or More are Orderd of One Size Your Company Name May Be Cast on Frame.
Diamond Tread. Painted: Bituminous Paint.
*Alternate Steel Checkered Plate Covers Available—Not Lettered.

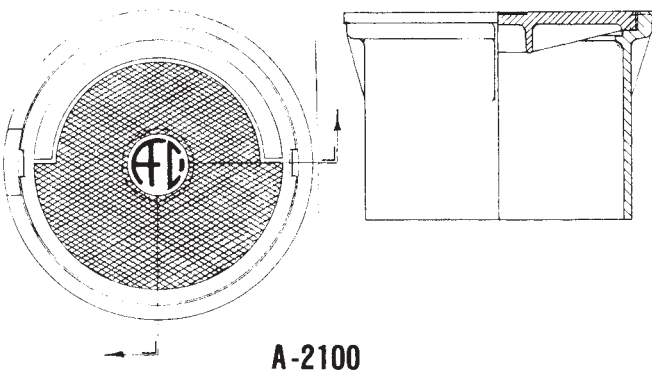

**CAST IRON ROUND COVER AND FRAME
LONG BODY
SLOW MOVING TRAFFIC**

PLATE NUMBER	COVER SIZE	OVERALL TOP	HEIGHT FRAME	APPROX. WEIGHT
A-2100	10	11	7½	30

If 25 or More are Ordered of One Size Your Company Name May Be Cast on cover.
Painted: Bituminous Paint.

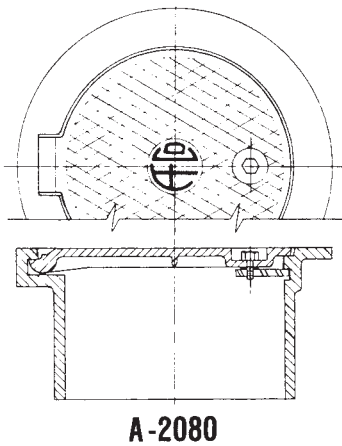

**CAST IRON INSPECTION PORT
HINGED COVER WITH LOCKING DEVICE
SLOW MOVING TRAFFIC**

PLATE NUMBER	CLEAR OPENING	COVER SIZE	OVERALL TOP	HEIGHT FRAME	APPROX. WEIGHT
A-2080	8	8½	11½	5½	30

Diamond Top Cover. Painted: Bituminous Paint.

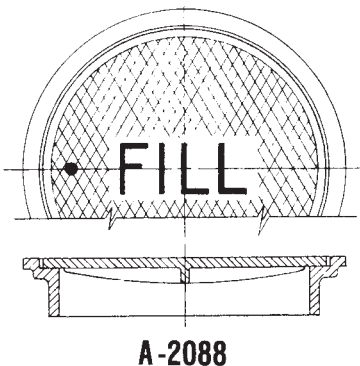

**CAST IRON FILL BOX COVER AND FRAME
SLOW MOVING TRAFFIC**

PLATE NUMBER	CLEAR OPENING	COVER SIZE	OVERALL TOP	HEIGHT FRAME	APPROX. WEIGHT
★ A-2088	14	15¾	18	3	45
★ A-2089	16	17¾	20	3	60

Conforms to Union Oil Standard Fill Box Drawing. Diamond Top Cover. Painted: Bituminous Paint.

Note: Marked Fill or Pump. Alternate Steel Checkered Plate Covers Available — Not Lettered.

★ — signifies more favorable stock and volume production



**Service Station Fill Line Covers and Frames
FOR USAGE OVER UNDERGROUND CONNECTIONS**

**CAST IRON ROUND COVER AND FRAME
WITH LIFT HANDLE
SLOW MOVING TRAFFIC**

PLATE NUMBER	CLEAR OPENING	OVERALL TOP	HEIGHT FRAME	APPROX. WEIGHT
A-2090	4	6	2 5/8	8
A-2091	6	8	2 5/8	12
A-2092	8	10	2 5/8	18
A-2093	12	14	2 5/8	28

Diamond Tread. Painted: Bituminous Paint.

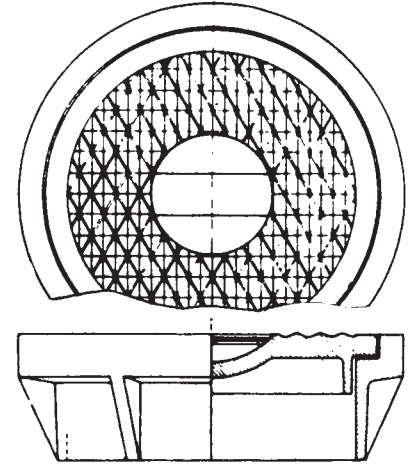

A-2090

**STEEL PLATE TURBINE PUMP COVER AND FRAME
SLOW MOVING TRAFFIC**

PLATE NUMBER	CLEAR OPENING	OVERALL TOP	HEIGHT FRAME	APPROX. WEIGHT
A-2094	16 x 16	18 x 18	8	50
A-2095	22 x 22	24 x 24	23	140

Covers held in Place with 2 Bolts. Also Made in Other Sizes. Painted One Coat Shop Primer.

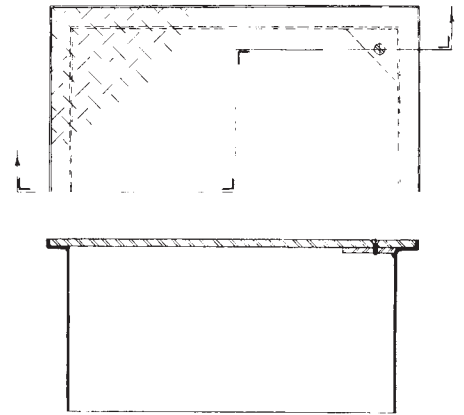

A-2094

**CAST IRON OVAL COVER AND FRAME
SLOW MOVING TRAFFIC**

PLATE NUMBER	COVER SIZE	OVERALL TOP	HEIGHT FRAME	APPROX. WEIGHT
★A-2099	8 x 18	10 x 19	3 1/2	23

If 25 or More Are Ordered of One Size Your Company Name May Be Cast on Frame at No Extra Charge. Diamond Tread. Painted: Bituminous Paint.

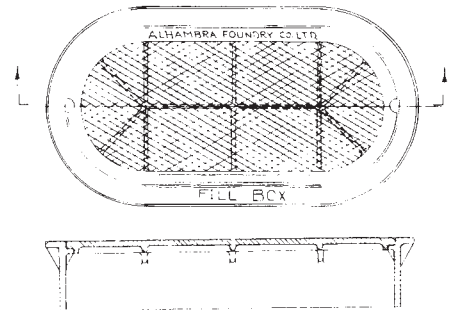

A-2099

★ — signifies more favorable stock and volume production

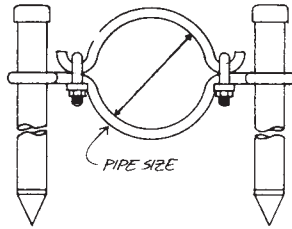

A-4022

DOWN DRAIN PIPE ANCHORS
³/₄ ROUND STEEL YOKES FOR
ANCHORING CORRUGATED CULVERT PIPE
A-4022 PIPE ANCHORS

PIPE SIZES

8 — 12 — 18 — 21 — 24 — 30

Specify Length of Stakes — 6 ft. Standard. 1 1/2 Inch Pipe Stakes, For Driving in Soil.
Give Size of Culvert Pipe When Ordering.

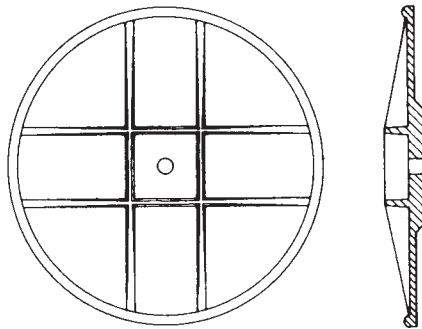

A-1670

ANCHOR PLATES FOR GUY WIRE ANCHORAGE

PLATE NUMBER	DIAMETER	APPROX. WEIGHT	PLATE NUMBER	DIAMETER	APPROX. WEIGHT
A-1671	8	10	★ A-1673	15	26
A-1672	10	14	★ A-1675	20	50

Cored Center Hole for Various Size Rods. Painted: Bituminous Paint.

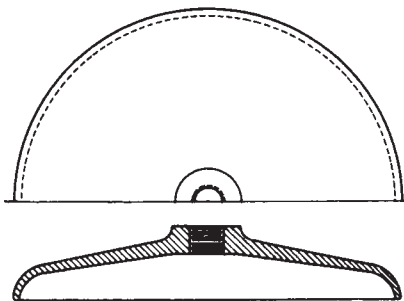

A-240

BASES FOR MOVABLE PIPE STANCHIONS
AUTOMOBILE CLUB TYPE

PLATE NUMBER	DIAMETER	TAPPED I.P.S.	APPROX. WEIGHT
A-241	18	2	40
A-242	15	1 1/4	21
A-243	12 1/2	1	21

Tapping Size May Vary on Specification.
Painted: Aluminum.

★ — signifies more favorable stock and volume production



CORNER WHEEL BUMPER

PLATE NUMBER	DIAMETER BASE	HEIGHT OVERALL	APPROX. WEIGHT
★ A-1980	12	22½	70
A-1981	24	21½	200

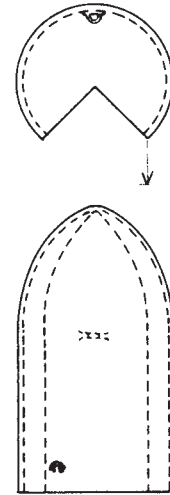

A-1980

CORNER WHEEL BUMPER WITH ANGLE CORNER GUARD

PLATE NUMBER	DIAMETER BASE	HEIGHT OVERALL	APPROX. WEIGHT
★ A-1982	12	60	110

Place Wheel Guards 1½" Below Concrete for Anchorage at Base.
Painted: Bituminous Paint.

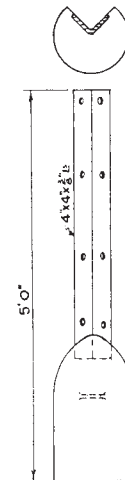

A-1982

WAREHOUSE CORNER WHEEL BUMPER

PLATE NUMBER	DIAMETER BASE	HEIGHT OVERALL	APPROX. WEIGHT
A-1983	8	12	30

Anchor Bolts Not Furnished. Painted: Bituminous Paint.

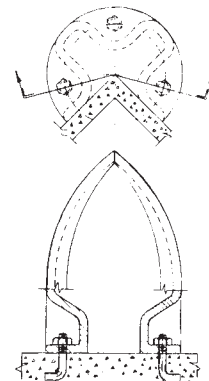

A-1983

★ — signifies more favorable stock and volume production



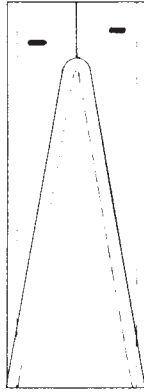
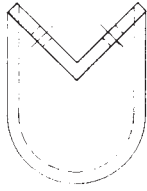

A-1984

CORNER WHEEL BUMPER

PLATE NUMBER	WIDTH	HEIGHT OVERALL	MAX. DEPTH	APPROX. WEIGHT
★A-1984	10	28	12½	135

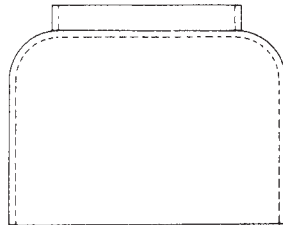
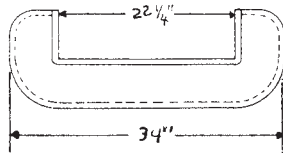

A-1985

**DOORWAY WHEEL GUARD
HEAVY DUTY**

PLATE NUMBER	WIDTH	HEIGHT OVERALL	METAL THICKNESS	APPROX. WEIGHT
A-1985	34"	27"	¾	380

Top Flange Drilled for Anchor Bolts. Patterns Adaptable for Various Width Only.

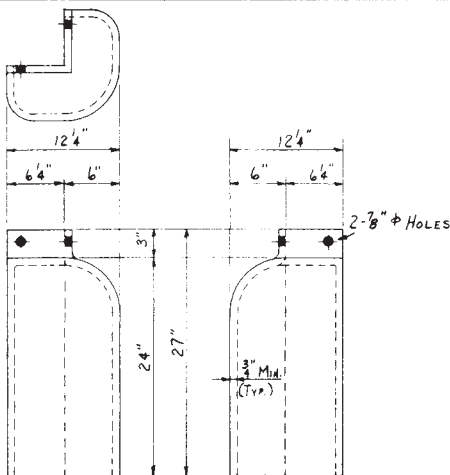

A-1986

HEAVY DUTY CORNER WHEEL GUARD

PLATE NUMBER	WIDTH	HEIGHT OVERALL	METAL THICKNESS	APPROX. WEIGHT
A-1986	13	27	¾	160

Top Flange Drilled for Anchor Bolts. Place Wheel Guards 1½" Below Concrete for Anchorage at Base. Painted: Bituminous Paint.

★ — signifies more favorable stock and volume production

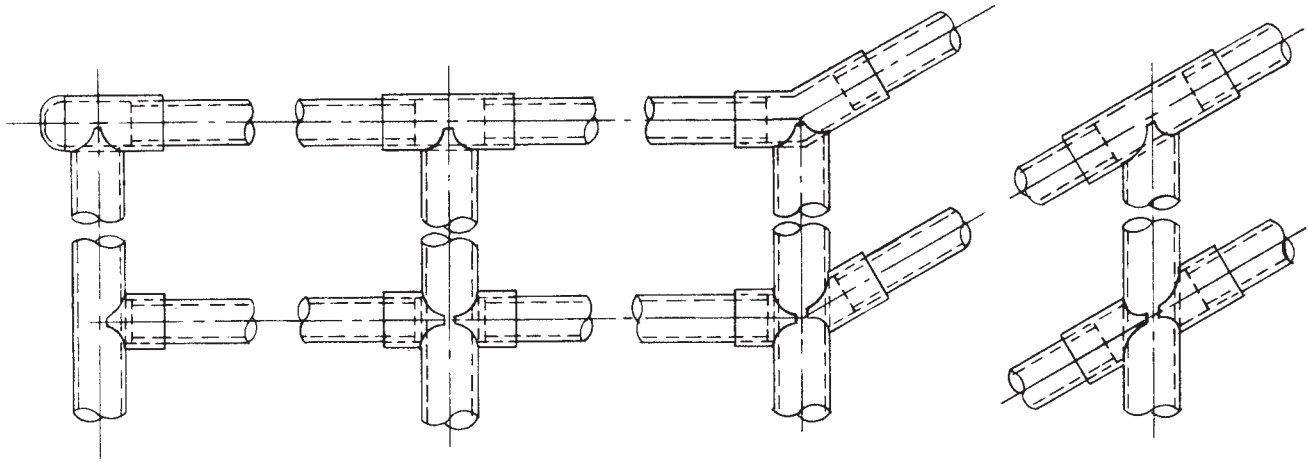

A-550

PIPE RAIL AND POSTS

D

Conforms to City of Los Angeles Standard Dwg. B-3499.

Size and Height of Posts Vary to Fit Job Requirement. Horizontal Rail Connections Are Either Slip Joint or Pinned or Combination of the Two. Post Anchoring Can Be Sleeve Insert, Plain End or Threaded for Floor Flange.

Other Styles Custom Built to Order.

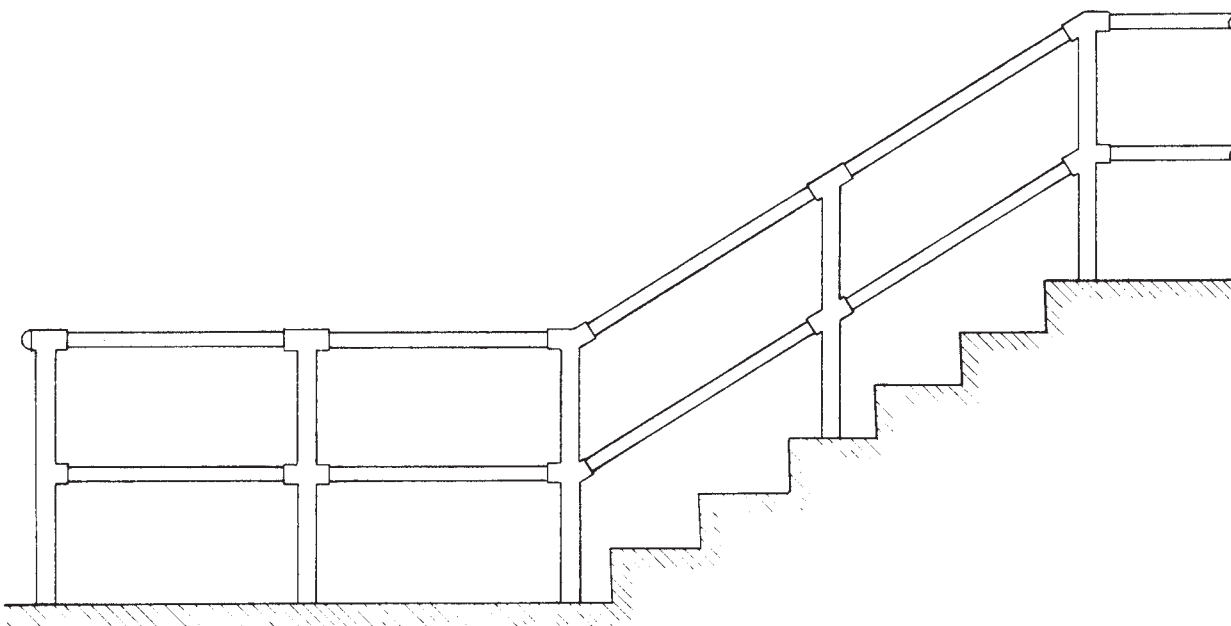



PIPE HANDRAIL AND BRIDGE RAIL

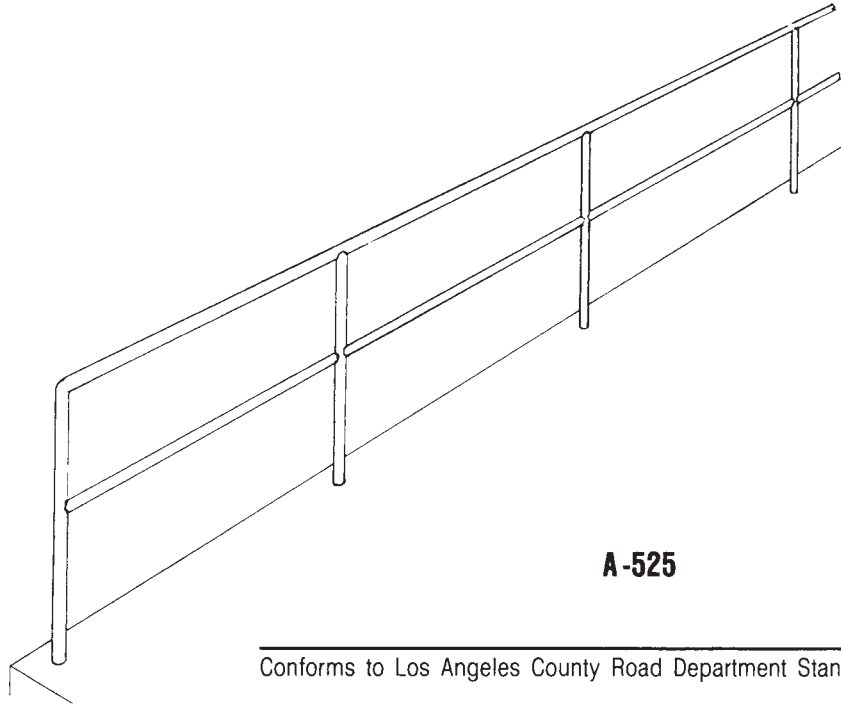

A-525

Conforms to Los Angeles County Road Department Standard Plan 88-02.

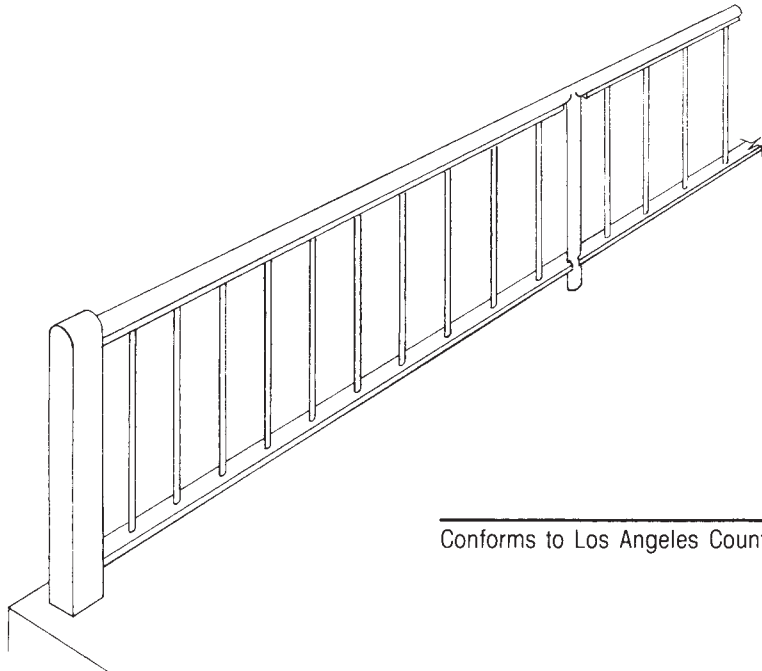

A-520

Conforms to Los Angeles County Road Department Standard Plan 106-01.

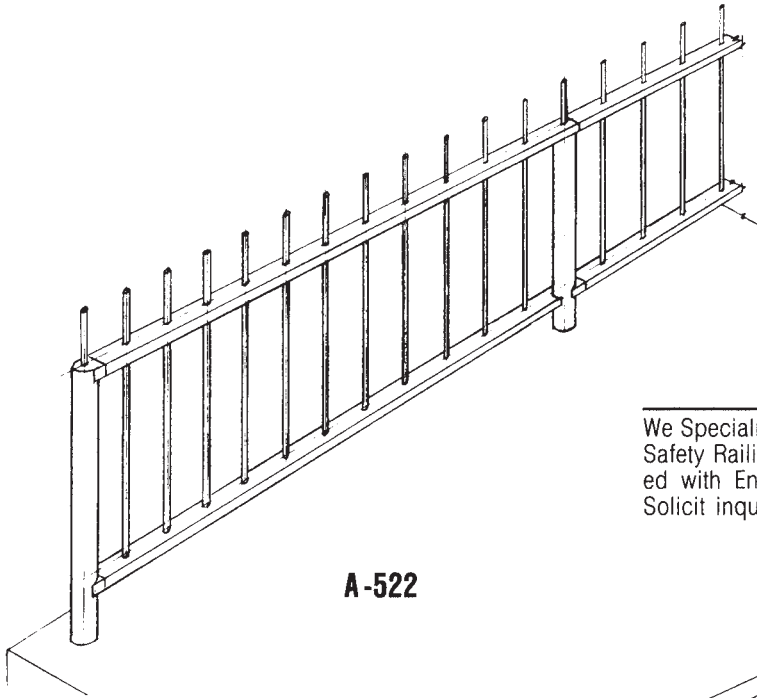

A-522

We Specialize in the Fabrication and Erection of All Types of Ornamental and Safety Railings. Particularly Bridge Railings. For Many Years We Have Worked with Engineering Offices Throughout the State on Design Details. We Solicit inquiries.

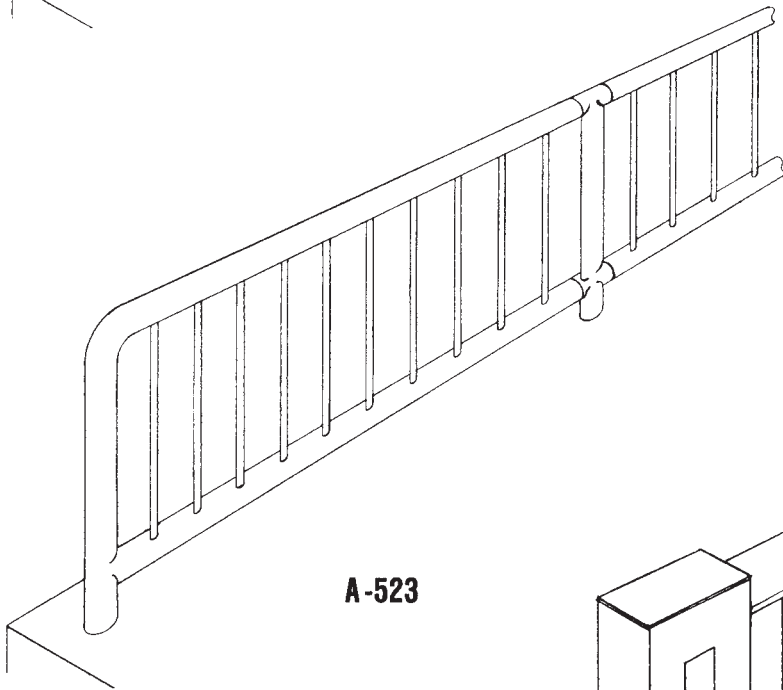

A-523

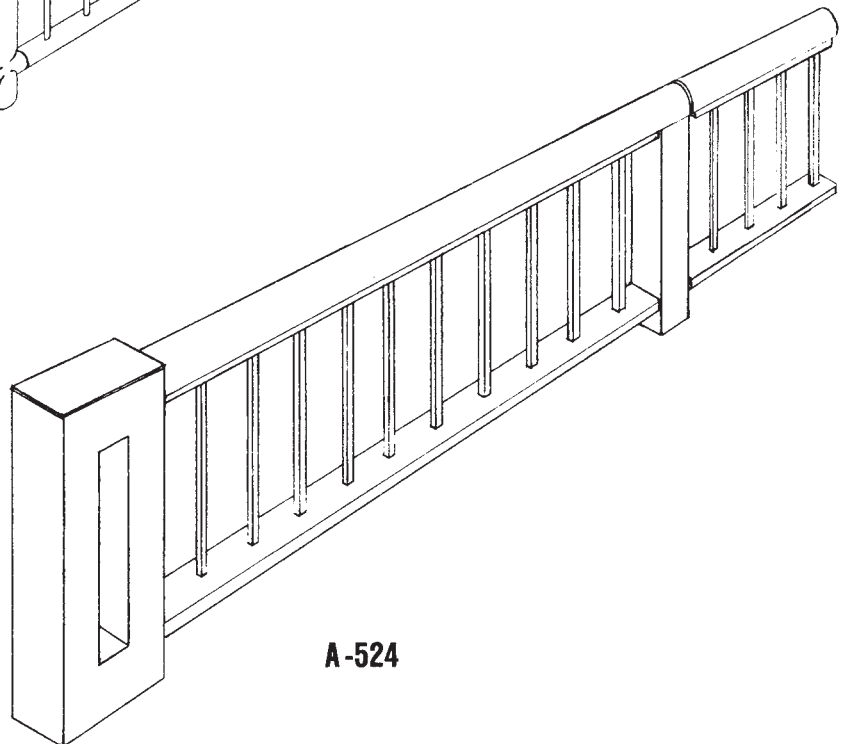

A-524

D



STEEL BARRIER RAIL

Conforms to State of California — Department of Transportation Standards.

TYPE 8

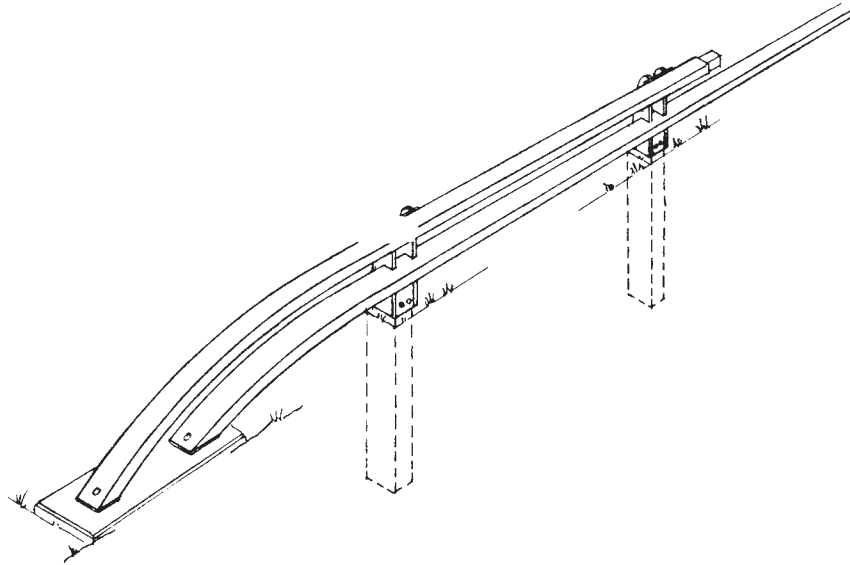

TYPE 9

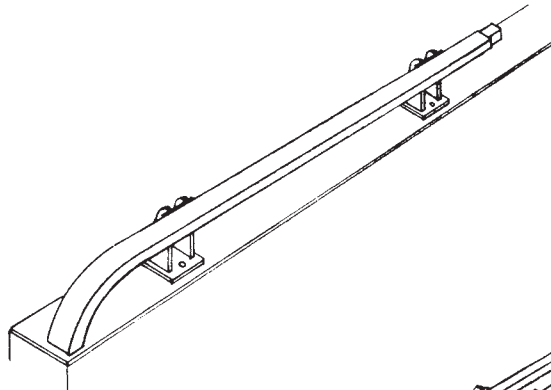

TYPE 11

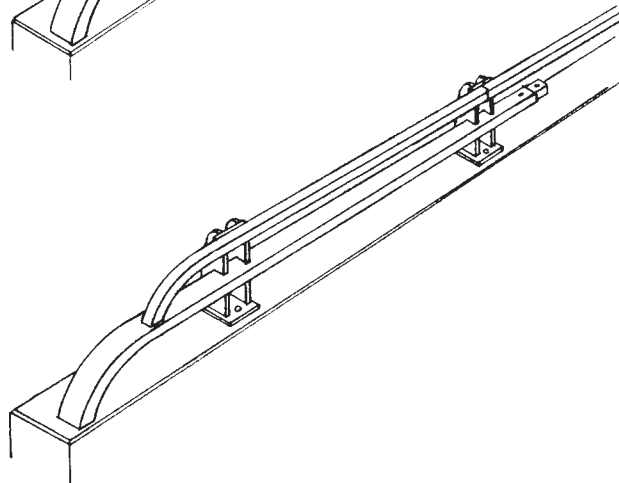

SECTION

E



**BUILDING
CONSTRUCTION
CASTING
HARDWARE**

E

Drains and Spiral Stairways

- | | |
|----------------------------------|-------------------------------|
| Rectangular Pipe Drains | Floor Drains |
| Government Cesspool Floor Drains | Spiral Stairways |
| Gutter Drains | Cast Iron Washers and Spacers |



**A-470 — RECTANGULAR CAST IRON PIPE
FOR USE UNDER SIDEWALKS
OR OTHER NARROW SPACES**

OUTSIDE PIPE	OUTSIDE HUBS	TRANSVERSE AREA — NET	LAYING LENGTH	WEIGHT
★ 3" x 5"	4¼"x6¼"	11.25 Sq. In.	5'0"	85
★ 3" x 5"	4¼"x6¼"	11.25 Sq. In.	2'6"	50
★ 3" x 9"	4¼"x10¼"	21.20 Sq. In.	5'0"	150
★ 3" x 12½"	4¼"x14"	30.00 Sq. In.	5'0"	200
★ 4" x 14"	5¼"x15¼"	47.50 Sq. In.	5'0"	220
★ 4" x 14"	5¼"x15¼"	47.50 Sq. In.	2'6"	115

Note: All Pipe Designed with Bell and Spigot Ends.

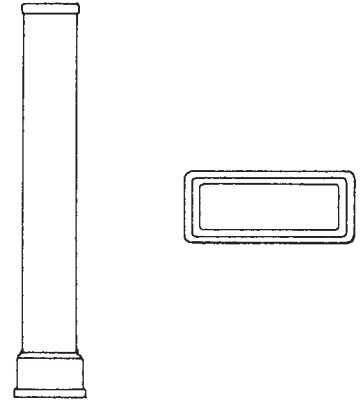

A-470

A-480 ADAPTORS — ROUND TO RECTANGULAR PIPE

ROUND PIPE	RECT. PIPE	LAYING LENGTH	WT.
★ 4"	3"x5"	1'0"	20
★ 5"	3"x9"	1'0"	45
★ 6"	3"x12½"	1'0"	35
★ 8"	4"x14"	1'0"	65

Note: All Adaptors Supplied with Bell and Spigot Ends Except for 6". 6" Adaptor Is No Hub Design.

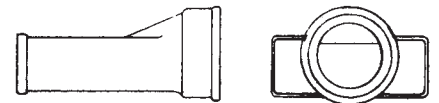
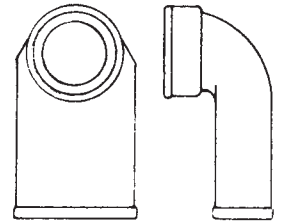

A-480

**CAST IRON WALL DRAIN
FOR USE IN WALLS OR PLANTERS IN MALLS
APPROX. WT. = 50 Lbs.**

Can be Furnished With Horizontal Bars Across Opening on Special Order.

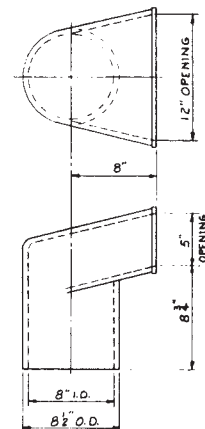

A-485

★ — signifies more favorable stock and volume production

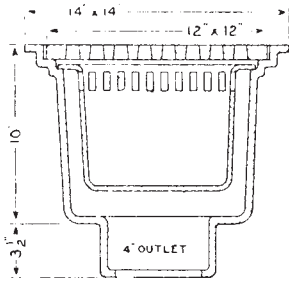

A-325

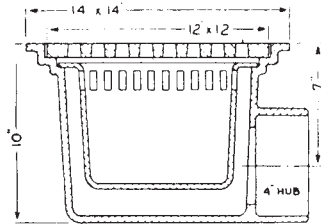

A-326

INDUSTRIAL FLOOR DRAINS

TRAFFIC PATTERN WITH SEDIMENT BUCKET

PLATE NUMBER	OUTLET SIZE	APPROX. WEIGHT
A-325	4	85
A-326	4	85

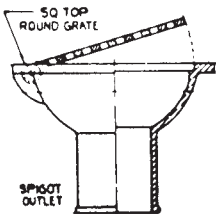

A-305

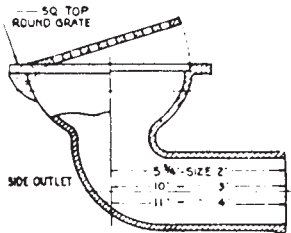

A-306

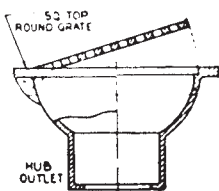

A-307

**AREA DRAINS
SQUARE TOP, ROUND HINGED GRATE
NON-TRAFFIC**

PLATE NUMBER	OUTLET	SIZE TOP	APPROX. WEIGHT
A-305-2	2	6 x 6	5
A-305-3	3	9 x 9	14
A-305-4	4	12 x 12	25
A-306-2	2	6 x 6	9
A-306-3	3	9 x 9	24
A-306-4	4	12 x 12	34
A-307-2	2	6 x 6	4
A-307-3	3	9 x 9	12
A-307-4	4	12 x 12	18

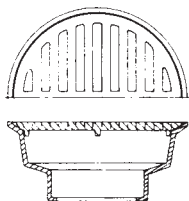

A-338

**A-338 — AREA DRAIN
NON-TRAFFIC**

PLATE NUMBER	SIZE OUTLET	TOP	WEIGHT	FINISH
★ A-338-3	3	9	11	Blk. Galvanized or Brass Top
★ A-338-4	4	9	11	Blk. Galvanized or Brass Top

Caulk Outlet Only.

★ — signifies more favorable stock and volume production



AREA DRAINS

PLATE NUMBER	GRATE SIZE	INSIDE DEPTH	OUTLET SIZES	B	C	D	APPROX. WEIGHT
A-344	12 x 12	5 1/2	4	14 x 14	6	1 3/4	50
A-344	13 3/4 x 13 3/4	5 1/2	6	16 x 16	6	2 1/4	65

Note: On 6" Outlets D Equals 2 1/4 Inches.
 A-344-4" Designed for Traffic.
 A-344-6" Designed for Non-Traffic Only.

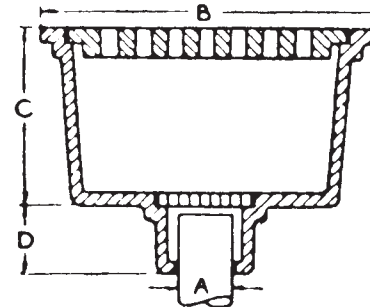

A-344

FLOOR SUMP FOR TRAFFIC

PLATE NUMBER	GRATE SIZE	INSIDE DEPTH	OUTLET SIZES	APPROX. WEIGHT
A-343	14 3/4 x 14 3/4	11	6	168

CAN BE FURNISHED WITH STRAINER AND BELL TRAP AS SHOWN TO CONTROL FUMES.

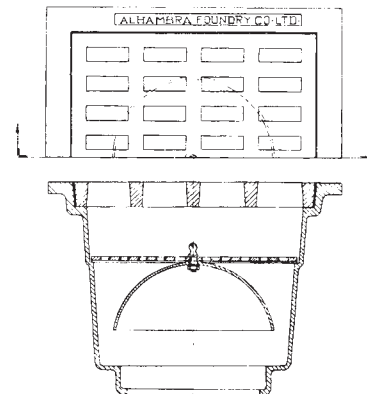

A-343

STATE TYPE GUTTERDRAINS FOR TRAFFIC

PLATE NUMBER	CLEAR OPENING	OVERALL TOP	HEIGHT	SIZE OUTLET	APPROX. WEIGHT
A-1291*	14 x 14	15 x 15	8 1/2	6	100
A-1292	11 3/4 x 17 3/4	12 1/2 x 18 1/2	9	7	85

* Conforms to Sacramento Drain No. 11. Painted: Bituminous Paint.

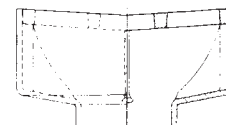
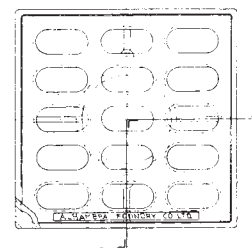

A-1291

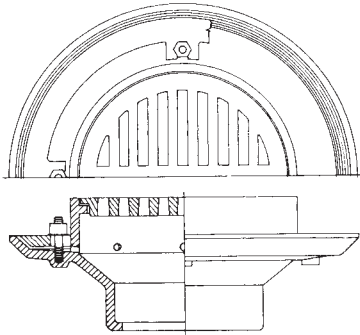

A-370

**FLOOR DRAIN
NON-TRAFFIC**

For Use Where Subject to Heavy Hand Trucking and to Intercept Coarse Debris. Clamping Ring Furnished on Specification Only.

PLATE NUMBER	SIZE OUTLET	TOP	OVERALL	HEIGHT	APPROX. WEIGHT
A-370-4	4	12	16	7	42
A-370-6	6	15	19¼	7	70

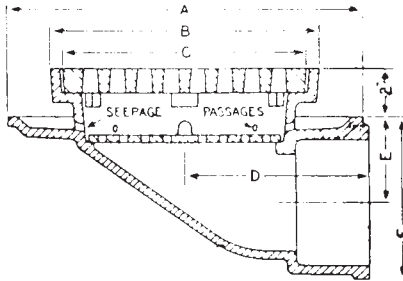

A-372

**SIDE OUTSIDE FLOOR DRAIN
NON-TRAFFIC**

PLATE NUMBER	SIZE OUTLET	A	B	C	D	E	APPROX. WEIGHT
A-372-4	4	16	12	11	8½	3½	45
A-372-6	6	16	12	11	8½	5½	46

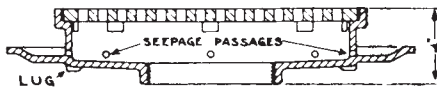
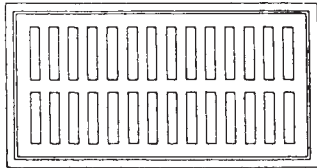

A-333

**GUTTER DRAIN
FURNISHED WITH OR WITHOUT SAFETY DRAIN
NON-TRAFFIC**

PLATE NUMBER	SIZE OUTLET	GRATE SIZE	TOP	PAN SIZE	HEIGHT	APPROX. WEIGHT
A-333-4	4	7¼ x 14¼	8 x 15	12½ x 19½	4	38
A-333-6	6	7¼ x 14¼	8 x 15	12½ x 19½	4	38

Caulk Outlet Only.

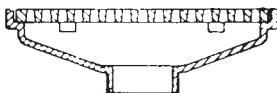
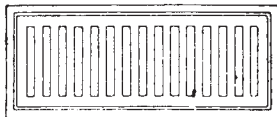

A-332

**GUTTER DRAIN
NON-TRAFFIC**

PLATE NUMBER	SIZE OUTLET	GRATE SIZE	TOP	HEIGHT	APPROX. WEIGHT
A-332-4	4	5¾ x 13¾	6⅞ x 14⅞	3½	18

Caulk Outlet Only.



**A-385 CLEANOUT FERRULES
RAISED HEAD
CAST IRON BODY — BRASS TOP**

SIZE FERRULE	LENGTH	APPROX. WEIGHT
2	5	2
3	5	3
4	5	6
5	5	8
6	5	11
8	5	16

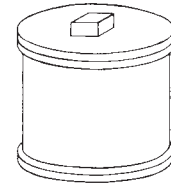

A-385

**A-386 CLEANOUT FERRULES
RECESSED HEAD
CAST IRON BODY BRASS TOP**

SIZE FERRULE	LENGTH	APPROX. WEIGHT
2	5	2
3	5	3
4	5	6
5	5	8
6	5	11
8	5	16

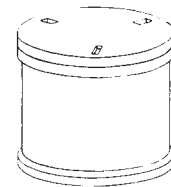

A-386

**A-387 CLEANOUT FERRULES
CAST IRON BODY — BRASS TOP**

SIZE FERRULE	LENGTH	APPROX. WEIGHT
4	5	6
6	5	11

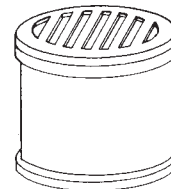

A-387

**A-386-B — SPECIAL CLEANOUT;
HEAVY BRASS BOLTED COVER
C. I. BODY**

SIZE FERRULE	LENGTH	APPROX. WEIGHT
6	5	12
8	5	18
12	5	34

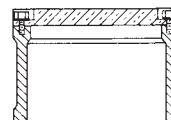
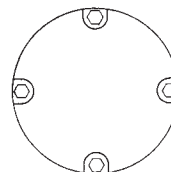

A-386-B

E



SPIRAL STAIRWAYS

A-3420

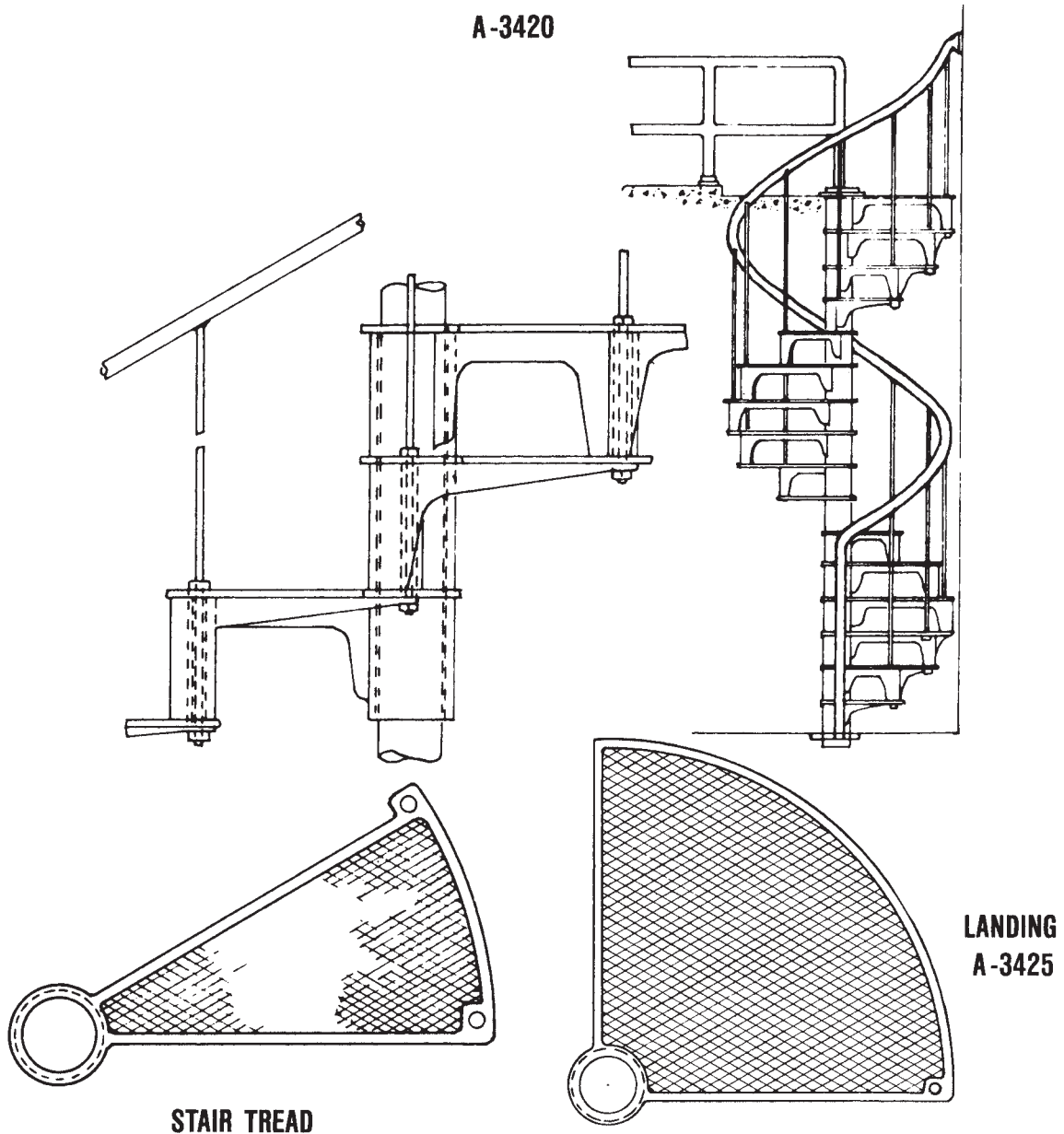

STAIR TREAD

**LANDING
A-3425**

A-3420 SPIRAL STAIRWAY — PRICES ON APPLICATION

Spiral Stairways for all Purposes. Custom Designed. Forty-eight, Fifty-four and Sixty Inch Diameters.

Cast Iron Steps with Raised Diamond Tread. Steps may be Carborundum Filled. Finish: Painted or Galvanized. Detail Drawings on Application.

Cast Iron Quarter Circle or Square Platforms Can be Supplied with Your Spiral Stairway.



FABRICATED STEEL SPIRAL STAIRWAYS

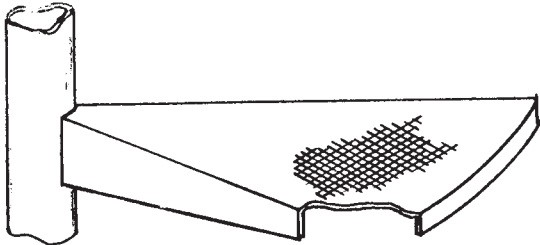

CHECKER PLATE STEP

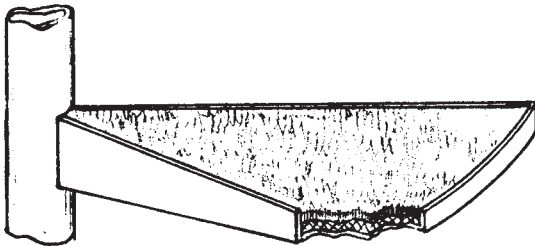

**SMOOTH PLATE STEP
FOR CARPET OR WOOD COVERING**

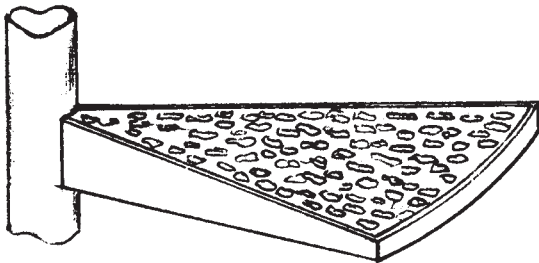

**PAN TYPE STEP
FOR CONCRETE OR TERRAZZO
FILLER**

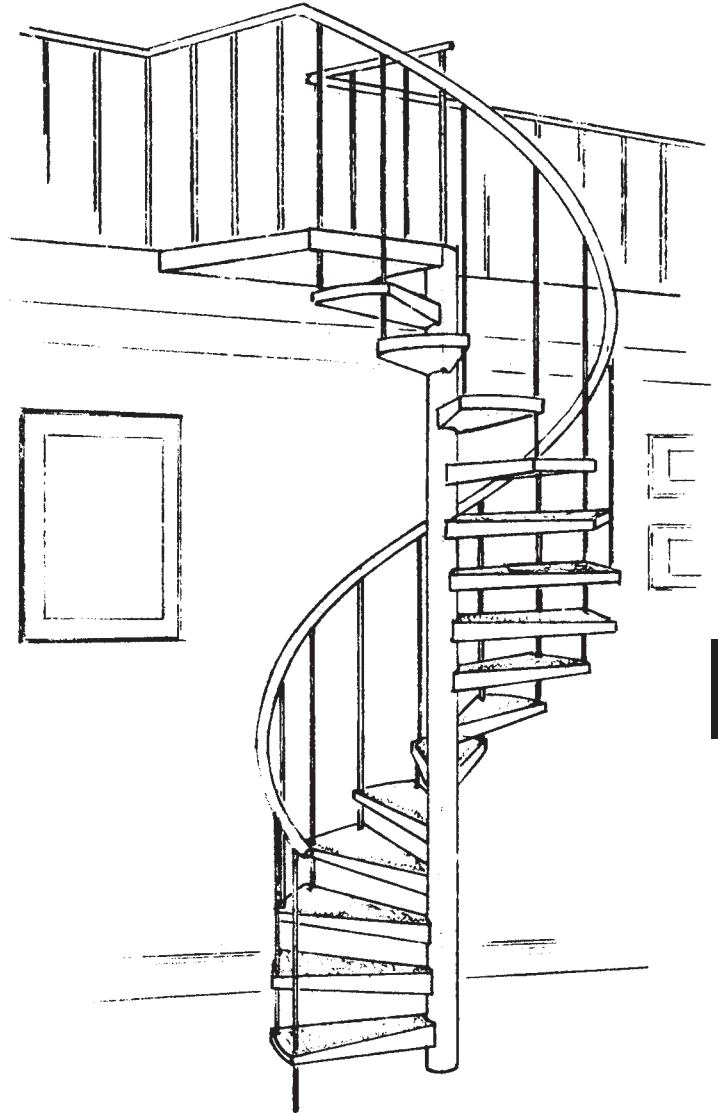

A-3430



Fabricated Spiral Stairways Offer Unlimited Possibilities for Modern Decorative Practice. Designed for Your Special Need. Finish: Painted or Galvanized. Price on Application.



MISCELLANEOUS CAST IRON WASHERS AND SPACERS

Black or Galvanized. Special Washers of Every Description.
Weights Given Are for Estimating Purposes Only.

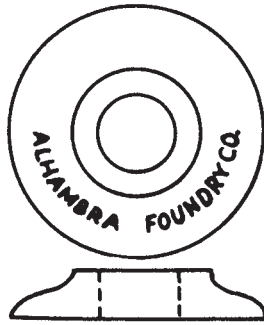

A-3510

STANDARD O. G. WASHERS

BOLT SIZE	DIAMETER	PLATE THICKNESS	*WEIGHT PER 100 PCS.
1/2	2 3/8	9/16	38
5/8	3	5/8	75
3/4	3 1/4	1 1/16	100
7/8	3 1/2	1 3/16	125
1	4	7/8	200
1 1/8	4 1/2	1 5/16	250
1 1/4	4 1/2	1	250
1 3/8	5 3/4	1 1/8	560
1 1/2	6	1 1/4	650
1 3/4	7	1 3/8	750
2	8	1 1/2	800

BEVEL OR ANGLE WASHERS

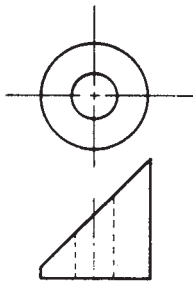

A-3540

A-3540-45* A-3550-60* A-3580-22 1/2* A-3570-30*

BOLT SIZE	DIAMETER	*WEIGHT PER 100 PCS.
1/2	2 7/8	50
5/8	3	125
3/4	3 1/8	125
7/8	3 3/8	200
1	4	200
1 1/8	4 3/4	250
1 1/4	5 1/4	350
1 1/2	6	500
1 3/4	7	800
2	8	900

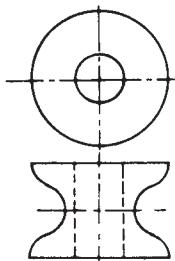

A-3600

**A-3600 — CAST IRON SPOOL 2" & 2 1/2" DIA.
2" LONG CENTER HOLE CORED TO SUIT**

SECTION

F



**ELECTRICAL
CASTINGS
and HARDWARE**

*Junction Boxes and
Boxes for Highway Bridges*

F



**CAST IRON
ELECTRICAL PULL-IN OR JUNCTION BOXES**

**RAINPROOF, BOLTED DOWN COVER AND GASKET
OUTLETS DRILLED AND TAPPED TO SUIT
MEASUREMENTS ARE FOR INSIDE OF BOX**

A-1680

Finish — Shop Coat of Primer. Galvanized on Request.

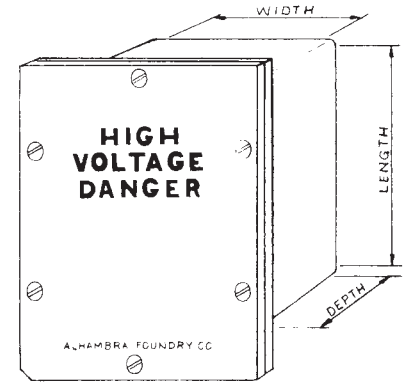

A-1680

WIDTH	LENGTH	DEPTH	WEIGHT
4	4	4	9½
4	6	4	11
4	8	4	15
6	6	4	16
6	6	6	20
6	8	6	34
6	12	6	39
6	12	8	48
8	8	4	35
8	8	8	50
8	12	6	56
8	12	8	64
12	12	6	52
12	12	12	97
12	18	8	115
12	18	12	130

Note—Sizes Listed Above are Normally Carried in Stock. Larger Sizes can be Quoted.
Your Inquiry is Invited.

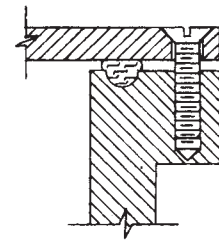

**VIEW LOOKING INTO BOX WITH SIDES LAID
DOWN. COVER REMOVED.**

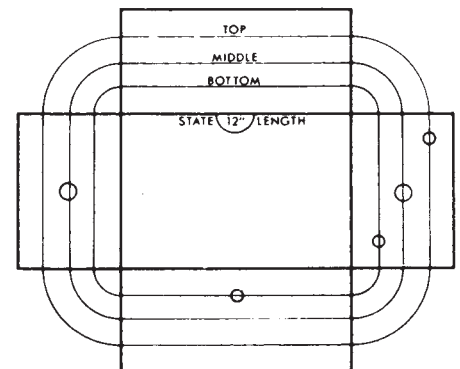

GIVE SIZE & ACCURATE LOCATION OF OUTLETS

**A SKETCH SIMILAR TO ABOVE SHOULD
ACCOMPANY YOUR ORDER.**

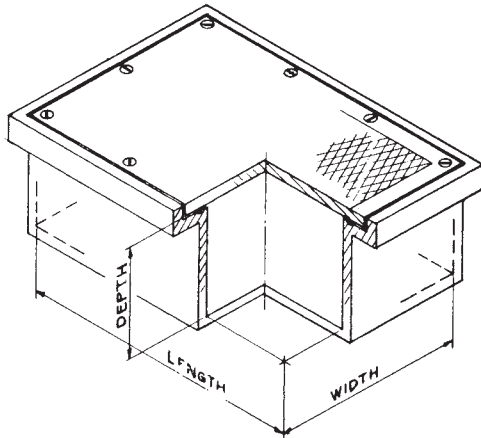

**CAST IRON
ELECTRICAL PULL-IN OR JUNCTION BOXES**

**RAINPROOF, BOLTED DOWN COVER AND GASKET
OUTLETS DRILLED AND TAPPED TO SUIT
MEASUREMENTS ARE FOR INSIDE OF BOX**

A-1677

Finish — Shop Coat of Primer. Galvanized on Request.

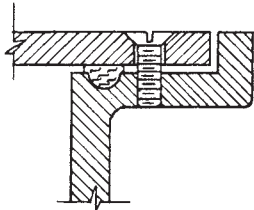

A-1677

**VIEW LOOKING INTO BOX WITH SIDES LAID
DOWN. COVER REMOVED.**

WIDTH	LENGTH	DEPTH	WEIGHT
4	4	4	16
4	6	4	26
4	8	4	28
6	6	4	28
6	6	6	31
6	8	6	35
6	12	6	55
6	12	8	60
8	8	4	51
8	8	8	60
8	12	6	68
8	12	8	73
12	12	6	90
12	12	12	120
12	18	6	120
12	18	8	135

Note—Sizes Listed Above are Normally Carried in Stock. Larger Sizes can be Quoted.
Your Inquiry is Invited.

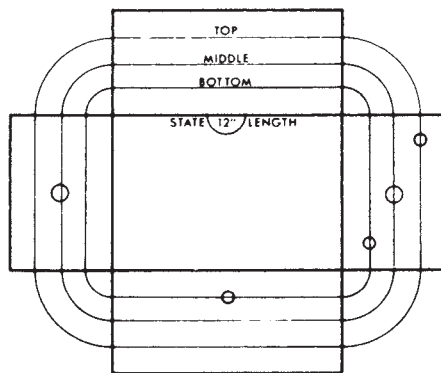

GIVE SIZE & ACCURATE LOCATION OF OUTLETS.

**A SKETCH SIMILAR TO ABOVE SHOULD
ACCOMPANY YOUR ORDER.**

WIDTH	LENGTH	DEPTH	WEIGHT
12	18	12	150
12	24	8	150
12	24	12	175
18	18	12	210
18	24	8	215
18	24	12	235
18	30	12	300
24	24	8	325
24	24	12	350
24	30	8	370
24	30	12	442
24	36	12	420
30	30	8	435
30	30	12	520

Note—These Sizes Are Not Normally Stocked But Can Be Produced on Order.



**ELECTRICAL BRIDGE PULL BOX FRAME AND
COVERS FOR LIGHTING AND SIGNAL CIRCUITS
TYPE II**

PLATE NUMBER	TYPE COVER	INSIDE DIMENSIONS			OVERALL DIMENSIONS			APPROX. WEIGHT
		WIDTH	LENGTH	DEPTH	WIDTH	LENGTH	DEPTH	
A-1662	Cast Iron	12	23	1½	15	26	1¾	56

Conforms to State of California Standard Drwg. ES-7A-4.
See Following Page for Standard Markings.

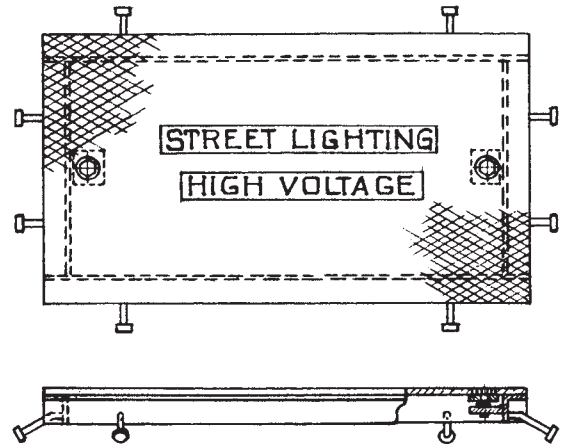

A-1662

**ELECTRICAL PULL BOX AND
COVERS FOR LIGHTING AND SIGNAL CIRCUITS
TYPE 9
FABRICATED STEEL**

PLATE NUMBER	WIDTH	OVERALL DIMENSIONS		DEPTH	APPROX. WEIGHT
		LENGTH	DEPTH		
A-1663	9¾"	24"	6½"	38#	

Conforms to State of California Standard Drwg. ES-7A.
See Following Page for Standard Markings.

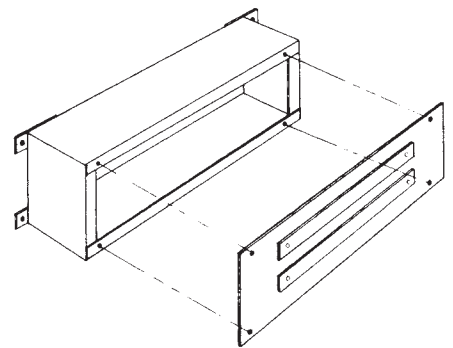

A-1663

F

**ELECTRICAL PULL BOX AND
COVERS FOR LIGHTING AND SIGNAL CIRCUITS
TYPE 9A
FABRICATED STEEL**

PLATE NUMBER	WIDTH	OVERALL DIMENSIONS		DEPTH	APPROX. WEIGHT
		LENGTH	DEPTH		
A-1664	9¼"	21¾"	8½"	38#	

Conforms to State of California Standard Drwg. ES-7A.
See Following Page for Standard Markings.

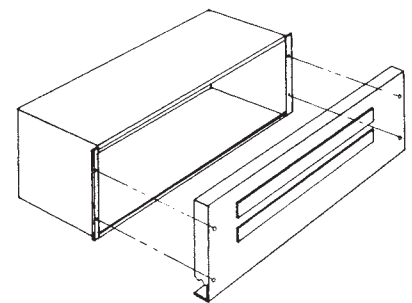

A-1664



A-1662, A-1663, A-1664

STANDARD PULL BOX MARKING
STATE OF CALIFORNIA — DEPARTMENT OF TRANSPORTATION

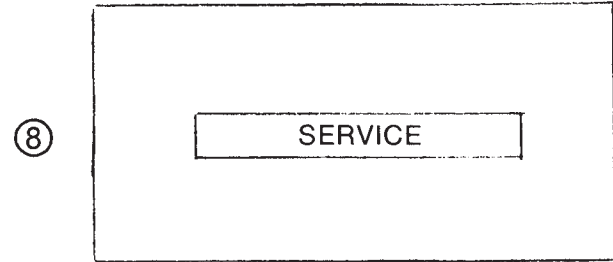
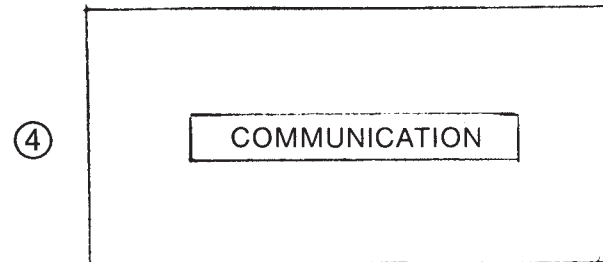
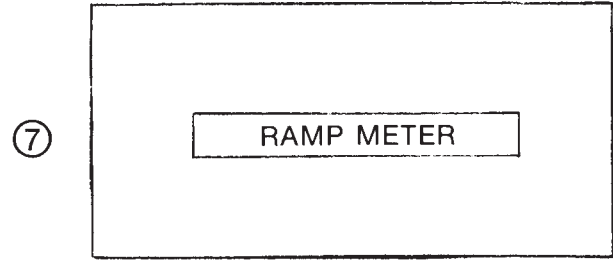
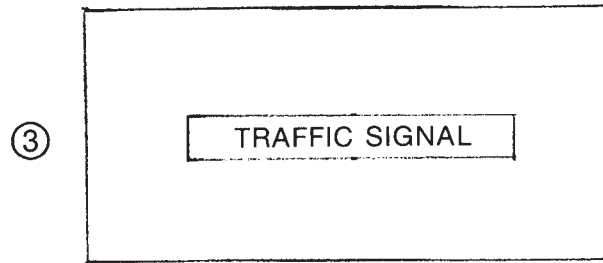
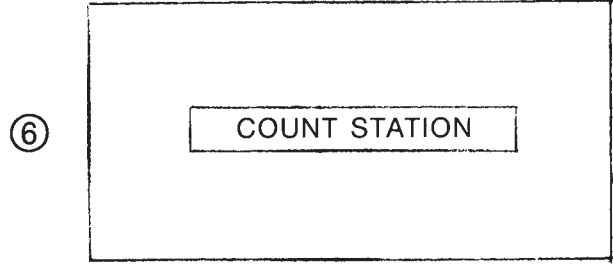
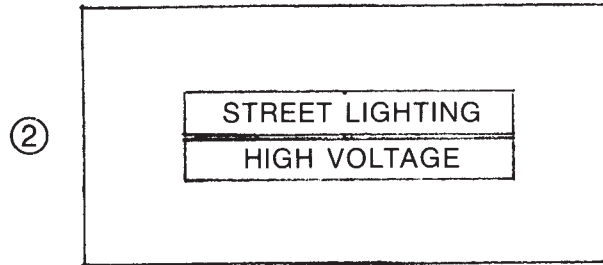
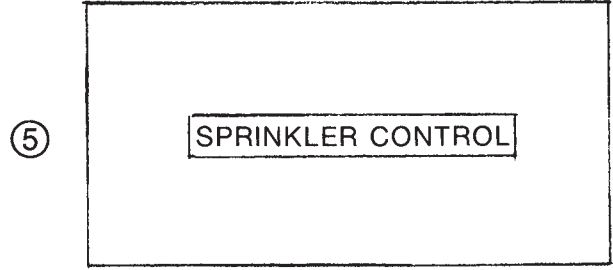
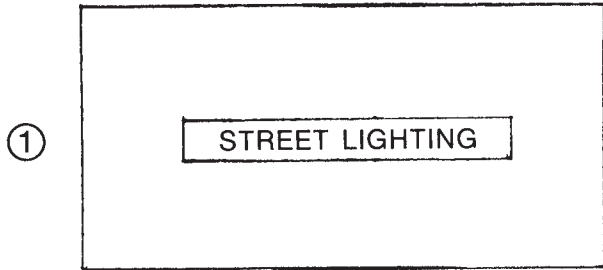

Note:
When ordering Pull Boxes A-1663 and A-1664 or Pull Box Frame and Cover A-1662,
indicate the marking required by code numbers 1 through 8 as shown above.

SECTION

G



MISCELLANEOUS PRODUCTS

G

Cast Iron Bushing Stock

Loafer Rail

Contractors Date Stamp

Breaking Balls

Tank Saddle Supports

Dock and Boat Hardware

Melting Pots

Manhole Lifting Device

Base for Movable Pipe Stanchions



CAST IRON BUSHING STOCK
PLATE NO. A-4280

REGULAR STOCK SIZES AND THEORETICAL WEIGHTS — SPECIAL SIZES AND LENGTHS MADE TO ORDER																			
SOLID 13" LONG									CORED 13" LONG										
Weight Size	Weight Round	Weight Hex	Weight Square	Weight Size	Weight Round	Weight Square	Outside Diam.	Inside Diam.	Weight	Outside Diam.	Inside Diam.	Weight	Outside Diam.	Inside Diam.	Weight	Outside Diam.	Inside Diam.	Weight	
1	2 3/4	3	3 1/2	4 3/4	60	76 1/2	2 x 1		8	3 1/2 x 1 1/4	28 1/4	4 1/4 x 2	36 3/4	5 1/4 x 3 1/4	42 1/2	6 1/2 x 4 1/2	58 1/4		
1 1/4	4 1/4	4 3/4	5 1/2	5	66 1/2	84 1/2	2 1/4 x 1		10 3/4	3 1/2 x 1 1/2	26 1/2	4 1/4 x 2 1/2	31	5 1/4 x 3 3/4	33 1/2	7 x 3	106		
1 1/2	6	6 1/2	7 1/2	5 1/4	70 1/2	94	2 1/4 x 1 1/4		10 1/2	3 1/2 x 1 3/4	24 1/4	4 1/2 x 1 1/2	47 3/4	5 1/2 x 2	69 1/4	7 x 4	89		
1 3/4	8 1/4	9	10 1/2	5 1/2	80	102	2 1/4 x 1 1/2		9 1/2	3 1/2 x 2	21 3/4	4 1/2 x 1 3/4	45 1/2	5 1/2 x 3	56	7 x 5	63 1/2		
2	10 3/4	12 1/2	13 1/2	5 3/4	87	112	2 1/2 x 1		13 3/4	3 3/4 x 1 1/4	32 3/4	4 1/2 x 2	43	5 1/2 x 3 1/2	47 1/2	7 1/2 x 4	108		
2 1/4	13 1/2	16	17	6	96	122	2 3/4 x 1		17 1/2	3 3/4 x 1 1/2	31	4 1/2 x 2 1/4	40 1/4	5 1/2 x 4	39	7 1/2 x 5	82 1/2		
2 1/2	16 1/2	19 1/2	21	6 1/4	104	132	2 3/4 x 1 1/4		15 3/4	3 3/4 x 1 3/4	28 3/4	4 1/2 x 2 1/2	37 1/4	5 3/4 x 3	63	7 1/2 x 6	53		
2 3/4	20	24 1/2	26	6 1/2	112	143	3 x 1		21 1/4	3 3/4 x 2	26 3/4	4 3/4 x 2 1/4	46 1/2	5 3/4 x 4	46	8 x 4	129		
3	24	28 1/2	30	7	130	166	3 x 1 1/4		19 3/4	3 3/4 x 2 1/4	23 1/2	4 3/4 x 2 1/2	43 1/2	6 x 2	85 1/4	8 x 5	103 1/2		
3 1/4	28	32	28 1/2	7 1/2	149	190	3 x 1 1/2		18	4 x 1	38 1/4	4 3/4 x 3	36	6 x 3	72	9 x 5	147 1/2		
3 1/2	32 1/2	35	41 1/2	8	170	216	3 1/4 x 1		25 1/4	4 x 1 1/2	35	5 x 2	55 3/4	6 x 4	55	10 x 6	169		
3 3/4	37	40	47 1/2	9	214	274	3 1/4 x 1 1/4		23 3/4	4 x 1 3/4	32 3/4	5 x 2 1/2	50	6 1/4 x 3	80	12 x 8	212		
4	42 1/2	49	54	10	265	338	3 1/4 x 1 1/2		22	4 x 2	30 1/4	5 x 3	42 1/2	6 1/4 x 4	63				
4 1/4	47 1/2		61	11	322	425	3 1/4 x 2		17 1/4	4 x 2 1/4	27 1/2	5 x 3 1/2	34	6 1/2 x 3	88				
4 1/2	53 3/4		68 1/2	12	382	487	3 1/2 x 1		29 3/4	4 x 2 1/2	24 1/2	5 x 4	25 1/4	6 1/2 x 4	71				

BRONZE DATE STAMP
CONTRACTORS CURB AND
SIDEWALK STAMP.
REVERSE LETTERS.
REMOVABLE YEAR INSERT
MAY BE ORDERED SEPARATELY

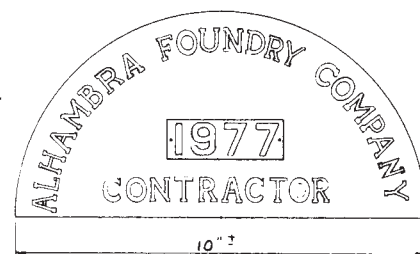
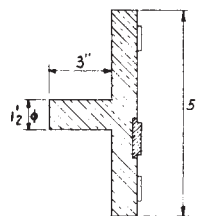

NOTE: Letter Heights = 15/16"

A-500



BRONZE NUMERALS
REVERSE NUMERALS FOR CONCRETE STAMPING
POLISHED AND DRILLED FOR
MOUNTING ON BOARD

PLATE NUMBER	HEIGHT LETTER	WIDTH LETTER	LETTER THICKNESS
A-501	4 1/2	3/4"	1/4

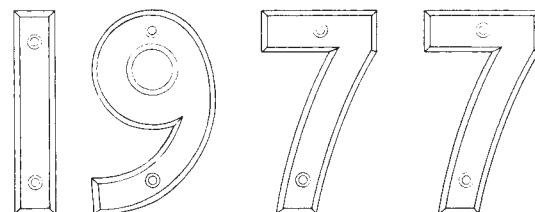

A-501

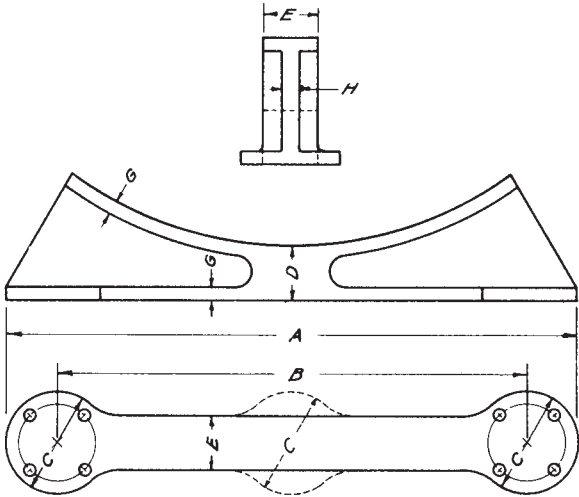

A-2750

**CAST IRON SADDLE TANK SUPPORTS
WITH INTEGRAL COMPANION FLANGES**

PLATE NUMBER	DIAM. OF TANK	SIZE FLANGE	A	B	C	D	APPROX. WEIGHT
A-2754	42	2½	42	35	7	2½	83
A-2755	48	2½	48	41	7	2½	103

Integral Flanges are Drilled to Bolt Circle Standards.

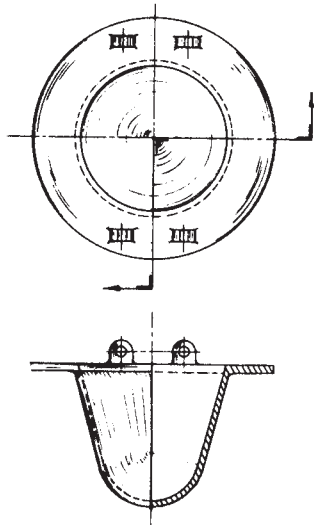

A-2850

CAST ALLOY MELTING POTS

PLATE NUMBER	INSIDE DIAMETER	DEPTH	OUTSIDE FLANGE
A-2851	18	14	22½
A-2852	18	18	30
A-2853	34	36	44

Furnished with or without Lifting Eyes.

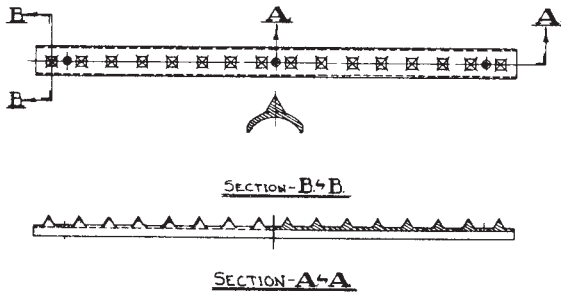

A-2370

CAST IRON LOAFER RAIL

PLATE NUMBER	PIPE SIZE	WIDTH	LENGTH	APPROX. WEIGHT
A-2370	2	1½	24	2.5



CAST IRON T-HEAD BOLT INSERT

PLATE NUMBER	DIAMETER	LENGTH	BOLT SIZE	WEIGHT
A-659	4"	6 ⁷ / ₈ "	1"	12.5

For Attaching Timber Piles or Bumpers to Concrete Wharf or Dock. Finish: Bituminous Paint or Galvanized.

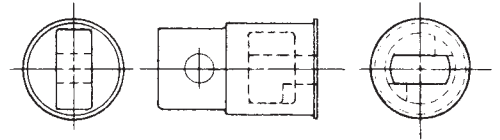

A-659

MANHOLE COVER LIFTING HOOK

PLATE NUMBER	DIAMETER	LENGTH	WEIGHT
A-3330	⁵ / ₈ "	21 ¹ / ₄ "	3.5

For use with Most Types of Manholes.

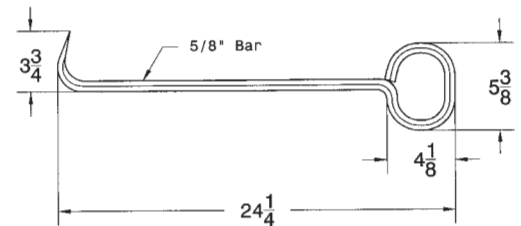

A-3330

G

DROP BREAKING BALLS
PRICES ON APPLICATION

LINK, PINS AND SWIVELS FURNISHED ON ORDER
PRICES ON APPLICATION

Pattern Weight Available. 2,000 lbs., 2,500 lbs., 3,000 lbs., 3,560 lbs., 4,000 lbs., 5,800 lbs., 8,000 lbs., 10,250 lbs.

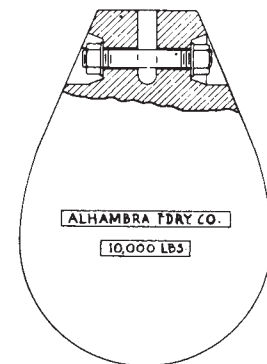

A-2840

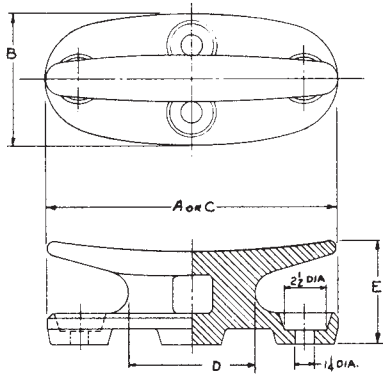

A-2810

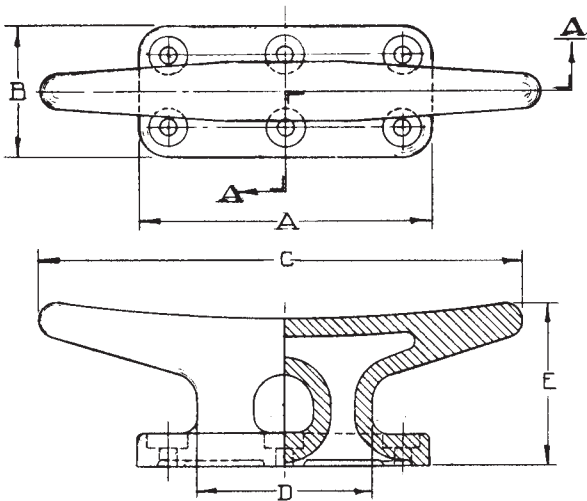

A-2811

A-2812

DOCK AND BOAT HARDWARE

**CAST IRON MOORING CLEATS
TABLE OF DIMENSIONS**

CAT. NO.	DESCRIPTION	A	B	C	D	E	WEIGHT
A-2810	18" Mooring Cleats	18	8	18	8 1/2	6 1/2	82
A-2811	24" Mooring Cleats	16 3/8	10 3/8	24	12	7 1/4	110
A-2812	42" Mooring Cleats	25	11	42	15	14	340

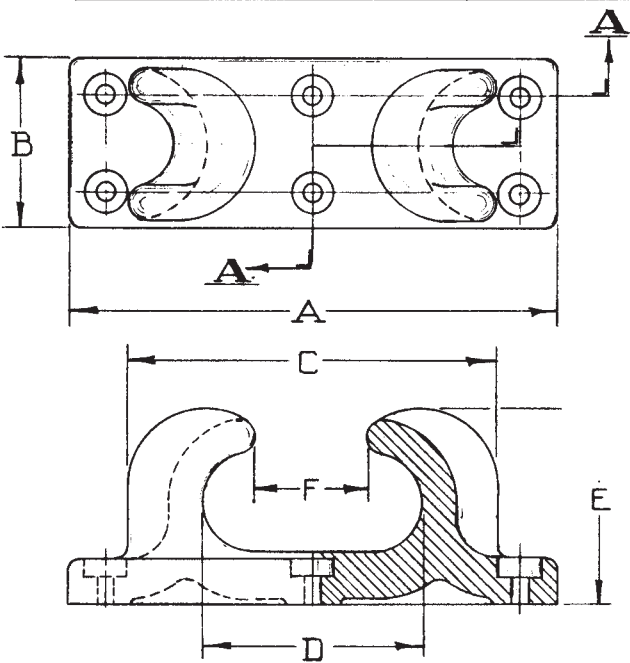

A-2815

**CAST IRON CHOCK
TABLE OF DIMENSIONS**

CAT. NO.	DESCRIPTION	A	B	C	D	E	F	WEIGHT
A-2815	7" Chock	28 3/4	10	21 1/2	13	11 1/2	7	280

SECTION

H



ALHAMBRA FOUNDRY COMPANY, LTD.

**ALPHABETICAL
INDEX**

**NUMERICAL
INDEX**

H



A

Adaptors, Rectangular PipeE-1
 Gate BoxD-3
 Adjustable InletC-17
 Adjusting Rings For Manhole FramesA-14
 Adjustable Valve BoxesD-5, 6
 Aircraft GratesC-25
 Anchor Plates, Guy WireD-10
 Angles, Catch Basin, Curb InletB-5
 Angle Cleanout Cover and FrameA-16
 Area DrainsE-2

B

Balls, Drop BreakingG-3
 Protection BarsB-6
 Barriers, ProtectionNS
 Bases, Movable Pipe StanchionD-10
 Bevel Washers, Cast IronE-8
 Bicycle Proof GratesC-1
 Boxes, ElectricalF-1, 2, 3
 Gate SubdrainD-3
 Service Station FillD-8, 9
 Sidewalk, HingedD-7
 Splice, Cover & FrameA-19
 ValveD-4
 Valve ExtensionD-5
 Brass Grate & FrameC-23
 Bridge, Electrical Pull BoxF-3
 Bridge RailingD-14, 15, 16
 Bronze Date StampG-1
 NumeralsG-1
 Bulb Nose Curb InletB-5
 Bumper, Corner Wheel GuardD-11, 12
 Bushing Stock, Cast IronG-1

C

Cable RacksNS
 Caps, Valve BoxD-4
 Catch Basin Covers & FramesA-12, C-5
 Grates & FramesC-2, 2, 17
 Curb Opening HardwareB-1, 5, 6
 Cesspool, Area GratesE-2
 Cover & FrameA-10
 Chocks, Cast Iron MooringG-3
 Cleanout, FerrulesE-5
 Frame & CoverA-16, C-6, 14
 Cleats, Cast Iron MooringG-4
 Concentric Manhole Covers & FramesA-13
A-21, 22, 23
 Concrete Filled Covers & FramesA-12, 24
C-7
 Concrete Curb & Sidewalk StampG-1
 Covers and Frames, AccessA-14, 25, 26
C-9, D-7
 Blow-off ThankA-2, C-19
 BoltedA-2
 Catch BasinA-12, C-5, 20, 21
 CesspoolA-10
 CleanoutA-16, C-6, 14
 CulvertC-15, 16, 18
 Electric ManholeA-6, 18, 19, 20, 21, 23
 Electric VaultA-24, 25, 26
 Fill LineD-8, 9

Garage SandtrapC-25
 Government TypeA-5, 6, 11, C-6, 9
 HingedC-9, 16, D-7, 8
 LampholeA-16
 Manhole, GeneralA-1, 3, 6, 7, 8
A-10, 13, 23
 Manhole, BoltedA-2, 22
 Manhole, LockingA-4, 5
 Manhole, PressureA-3, 15
 Manhole, Raising RingsA-14
 MonumentA-16, 17
 Navy StandardA-6, 11
 Pull BoxA-26
 RectangularA-19, 26, C-4, 5, 6, 8
C-15, 16, 22, 23
 SandtrapC-25
 Service StationD-8, 9
 Splice BoxA-19
 TrenchC-26
 TroughC-28, 29
 ValveD-5, 8
 Culvert Frames & CoversC-15, 16
 Culvert, Rail ReinforcingC-15
 Curb InletB-5, C-19
 Curb Inlet Protection BarsB-6

D

Drainage Grates & Frames, AircraftC-27
 RoundA-1, 3, 4, 6, 9, 12, C-24, 30
 SquareC-3, 20, 21, 22, H-21
 RectangularC-1, 2, 3, 22, 23, 25
 TrenchC-26, 27, 28, 29
 Drains, Plumbing, AreaE-2
 FloorE-2, 3, 4
 GutterE-2, 3, 4
 WallE-1
 Drop BallsG-3

E

Electrical Manhole Covers & FramesA-18, 19
A-20, 21, 22, 23
 Electrical Pull Box Covers & FramesA-26
F-1, 2, 3
 Electrical Vault Covers & FramesA-24, 25
 Extension BoxesD-5, 6, 7
 Extension HandlesD-6
 Eye Bolt HangerB-6

F

Face Plates, Curb OpeningB-5
 Ferrules, Clean OutE-5
 Fill Boxes, Service StationD-8, 9
 Fire Hose Inlet, BrassD-7
 Flap Gate, AutomaticD-1
 Floor DrainsE-2, 3, 4
 Floor SinksE-2, E-3
 Forest Lawn Access Cover & FrameA-14
 Frames & GratesSee Grates & Frames
 Frames & CoversSee Covers & Frames

G

Gate, Boxes, Sub-drainD-1
 Flap ValveD-1

Garage, Sand TrapsC-25
 Grates, AreaC-22, 23, 24
 BeehiveA-9, C-3
 Bicycle ProofC-1, 22, 23
 BrassA-12, C-1, 2, 19
 Catch BasinA-12, C-1, 2, 19
 ConcaveC-3, 20
 DrainageC-30
 DuctileC-1
 Hub, Clay PipeC-30
 Hub, Soil PipeC-30
 ManholeA-1, 3, 4, 6, 9
 Navy StandardC-19, 20
 Pipe DrainC-30
 RaisedA-9, C-3
 Sand TrapC-25
 School BoardC-2
 Steel FabricatedC-1, 2
 Tide WaterA-9
 Tree WellC-10, 11, 12, 13, 14
 TrenchC-26, 27, 28, 29
 VentilatorB-4
 Grooves, Stop LogD-2
 Guards, Corner WheelD-11, 12
 Guywire Anchor PlatesD-10

H

Hand WheelsNS
 Handles, Valve Operating ExtensionD-6
 Hand RailsD-13, 14
 Hinged CoversA-26, C-9, D-7, 8

I

Index, Alphabetical
 Numerical
 Inlets, Catch BasinB-5, C-1, 2, 3
 CurbC-19
 Fire Hose, BasementD-7
 Inner PansA-3, 4, 5, 7, 19, 20, 21, 24, 25
 Insert, Cast Iron, T-Head BoltG-3
 Irons, PullingB-2

J

Junction BoxesF-1, 2

K

Keels, BoatG-3

L

Ladder RungsB-1, 2
 Support BarB-3
 Ladders, VaultB-3
 Lamphole, Covers & FramesA-16
 Lighting, Street Boxes, BridgeF-3
 Loafer RailG-2

M

Manhole Covers, APWA-AGC StandardA-3
 Airport LoadingA-10
 BoltedA-2, 22
 ConcentricA-13, 21, 22, 23
 Concrete Fill TypeA-12, 24, C-7
 CulvertC-15, 16, 18
 General UsageA-1, 2





Government Type	A-5, 6, 11
Inspection	A-8, 13, 14
Locking Type	A-4, 5
Navy Standard	A-6, 11
Pressure	A-3, 15
Sewer	A-1, 3, 4, 7, 8
Silent Knight	A-10
Storm Drain	A-1, 3, 4, 7, 8
Telephone	A-18, 19
Vault Electrical	A-6, 18, 19, 20, 21
Water Tight	A-23, 24, 25, 26
Manhole Lifting Device	A-2, 15, 22
Manhole Raising Rings	G-3
Manhole Trap Casting	A-14
Melting Pots	D-1
Molds, Ingot	G-2
Monument Frames & Covers	NS
mooring Chocks, Cleats	A-16, 17
Multiple Covers & Frames	G-4
	C-5, 13, 14
N	
Name Plate, Stamp	G-1
Navy Covers & Frames	A-6, 11
Grates & Frames	C-19, 20
Nosing, Rolled Plate	B-5
Numbers, Brass	G-1
O	
O. G. Washers, Cast Iron	E-8
Operating, Extension Handle	D-6
P	
Pans, Inner	See Inner Pans
Pan Type Covers	A-12, 24, C-7
Pavement Stamp	G-1
Pipe Anchors, Down Drain	D-10

Pipe Drain Grates	C-30
Pipe Handrail	D-13, 14
Pipe, Rectangular, Cast Iron	E-1
Plate, Sidewalk Culvert	C-18
Guy Wire Anchor	D-10
Pots, Melting	G-2
Pressure Frames & Covers	A-3, 15
Pressure Relief Valves	D-1
Protection Barriers	NS
Protection Bars	B-6
Protection Bar Anchors	B-6
Pull Boxes, Electrical	F-1, 2, 3
Pull Irons	

R

Racks, Cable	NS
Trash	NS
Raised Grate & Frame	A-9, C-3
Raising Rings, Manhole	A-14
Rails, Bridge	D-14, 15, 16
Pipe Hand	D-13, 14
Culvert Tops	C-15, 17
Loafer	G-2
Rectangular Pipe	E-1
Relief Valve, Pressure	D-1

S

Saddles, Tank	G-2
Sales, Terms & Conditions	VII
Sandtrap Covers	C-25
School Board Grates	C-2
Service Station, Covers & Frames	D-8, 9
Sidewalk Culvert Plates	C-18
Spiral Stairs	E-6, 7
Spools, Cast Iron	E-8
Stamp, Date	G-1
Stanchion, Movable Base	D-10

Steps, Manhole, Catch Basin	B-1, 2
Stop Log Grooves	D-2
Support Bolts	B-6

T

T-Head Bolt Insert	G-3
Tank Supports	G-2
Telephone Covers & Frames	A-18, 19
Terrazzo Filled Covers	A-12, 24, C-7
Test Station Cover & Frame	A-17
Tide Water Grate	A-9
Tiedown Anchor, Aircraft	D-10
Trap Castings, Manhole	D-1
Traps, Sand	C-25
Tree Well Guards	C-13
Tree Well Grates	C-10, 11, 12, 13, 14
Trench, Cover, Grates & Frames	C-26, 27
	C-28, 29
Trough Drains	C-28, C-29

V

Valve, Boxes	D-4
Flap Gate	D-1
Pressure Relief	D-1
Vault Covers & Frames	A-6, 18, 19, 20, 21
	A-23, 24, 25, 26
Vents, Cast Iron, Sidewalk	B-4
Pipe	B-4

W

Wall Drain	E-1
Washers, Cast Iron, Bevel & O.G.	E-8
Watertight Covers & Frames	A-2, 15, 22
Wheel Guards	D-11, 12

(NS INDICATES "NOT SHOWN." MADE TO ORDER)



FIG. NO.....PAGE	FIG. NO.....PAGE	FIG. NO.....PAGE	FIG. NO.....PAGE	FIG. NO.....PAGE
A-241D-10	A-1071A-20	A-1232C-19	A-1322A-6	A-1492A-3
A-242D-10	A-1072A-20	A-1233C-19	A-1323A-21	A-1493A-3
A-243D-10	A-1073A-20	A-1234C-19	A-1324A-21	A-1494A-13
A-305-2E-2	A-1074A-20	A-1235C-19	A-1325A-13	A-1495A-3
A-305-3E-2	A-1075A-21	A-1236C-19	A-1327A-7	A-1496A-3
A-305-4E-2	A-1076A-23	A-1237-BC-19	A-1328A-5	A-1497A-3
A-306-2E-2	A-1080A-26	A-1238-BC-19	A-1329A-5	A-1498A-3
A-306-3E-2	A-1081A-26	A-1240A-16	A-1330C-9	A-1499A-3
A-306-4E-2	A-1082A-26	A-1241A-16	A-1331C-9	A-1500A-3
A-307-2E-2	A-1083A-26	A-1242A-16	A-1332C-9	A-1501A-3
A-307-3E-2	A-1084A-26	A-1243A-16	A-1333C-9	A-1502A-3
A-307-4E-2	A-1085A-26	A-1244A-16	A-1334C-9	A-1503A-3
A-325E-2	A-1086A-26	A-1247A-16	A-1341C-4	A-1505A-5
A-326E-2	A-1087A-26	A-1251-4A-1	A-1342C-4	A-1513A-23
A-329-2C-30	A-1088A-26	A-1251-6A-1	A-1343C-4	A-1514A-21
A-329-3C-30	A-1089A-26	A-1252A-1	A-1350-2C-16	A-1515A-23
A-329-4C-30	A-1090A-26	A-1253A-1	A-1350-3C-16	A-1516A-23
A-329-5C-30	A-1091A-26	A-1254A-1	A-1350-4C-16	A-1517A-22
A-329-6C-30	A-1092A-26	A-1254-6A-1	A-1351-2C-16	A-1520-BA-2
A-329-8C-30	A-1093A-26	A-1255A-1	A-1351-3C-16	A-1521-BA-2
A-329-10C-30	A-1094C-18	A-1256A-1	A-1351-4C-16	A-1522-BA-2
A-332-4E-4	A-1100A-20	A-1259A-1	A-1352-2C-16	A-1530A-12
A-333-4E-4	A-1105A-19	A-1251-B-4A-2	A-1352-3C-16	A-1530-BA-12
A-333-6E-4	A-1106A-19	A-1251-B-6A-2	A-1352-4C-16	A-1533A-12
A-338-3E-2	A-1108A-19	A-1252-BA-2	A-1353-2C-16	A-1534A-12
A-338-4E-2	A-1110A-20	A-1253-BA-2	A-1353-3C-16	A-1535A-12
A-343E-3	A-1120A-18	A-1254-BA-2	A-1353-4C-16	A-1535-BA-12
A-344E-3	A-1121A-18	A-1254-B-6A-2	A-1360C-15	A-1540C-1
A-370-4E-4	A-1131A-18	A-1255-BA-2	A-1363C-15	A-1542C-1
A-370-6E-4	A-1132A-18	A-1256-BA-2	A-1365C-15	A-1544C-1
A-371D-7	A-1133A-18	A-1261-4A-1	A-1401C-9	A-1545C-1
A-372-4E-4	A-1134A-18	A-1261-6A-1	A-1402C-9	A-1546C-1
A-372-6E-4	A-1135A-18	A-1262A-1	A-1403C-9	A-1548C-2
A-385E-5	A-1136A-18	A-1263A-1	A-1404C-9	A-1551C-1
A-386E-5	A-1137C-7	A-1264A-1	A-1411A-11	A-1552C-1
A-387E-5	A-1138C-7	A-1265A-1	A-1412A-11	A-1553C-1
A-386-BE-5	A-1140A-11	A-1266A-1	A-1420-4A-6	A-1554C-1
A-391D-7	A-1142A-11	A-1261-B-4A-2	A-1420-6A-6	A-1555C-1
A-470E-1	A-1143A-11	A-1261-B-6A-2	A-1421A-6	A-1557C-1
A-480E-1	A-1144A-11	A-1262-BA-2	A-1422A-6	A-1558C-2
A-485E-1	A-1145A-11	A-1263-BA-2	A-1424A-6	A-1563B-6
A-500G-1	A-1147A-11	A-1264-BA-2	A-1425A-6	A-1564B-6
A-501G-1	A-1148A-10	A-1265-BA-2	A-1427A-6	A-1565B-6
A-520D-14	A-1170A-4	A-1266-BA-2	A-1430C-8	A-1569B-6
A-522D-15	A-1171A-4	A-1268-BA-2	A-1431C-8	A-1570B-6
A-523D-15	A-1172A-4	A-1270A-4	A-1432C-8	A-1571B-6
A-524D-15	A-1175A-4	A-1275A-13	A-1433C-8	A-1572B-6
A-525D-14	A-1176A-4	A-1281C-3	A-1434C-8	A-1573B-6
A-550D-13	A-1180A-14	A-1291E-3	A-1435C-8	A-1574B-6
A-659G-3	A-1190A-10	A-1292E-3	A-1450C-5	A-1575B-6
A-1001A-24	A-1191A-10	A-1301A-10	A-1451C-5	A-1576B-6
A-1002A-24	A-1193A-10	A-1302A-10	A-1452C-5	A-1577B-6
A-1003A-24	A-1200A-9	A-1303A-10	A-1453C-5	A-1578B-6
A-1004A-24	A-1210A-9	A-1310A-7	A-1470C-5	A-1579B-6
A-1010A-24	A-1215A-9	A-1311A-7	A-1471C-5	A-1581C-2
A-1030A-24	A-1220A-8	A-1312A-7	A-1472C-5	A-1583C-2
A-1031A-24	A-1221A-8	A-1314A-7	A-1473C-5	A-1584C-2
A-1050A-25	A-1222A-8	A-1315A-7	A-1480A-8	A-1585C-2
A-1055A-25	A-1223A-8	A-1320A-6	A-1490-BA-3	A-1586C-6
A-1060A-25	A-1231C-21	A-1321A-6	A-1491A-3	A-1590A-8



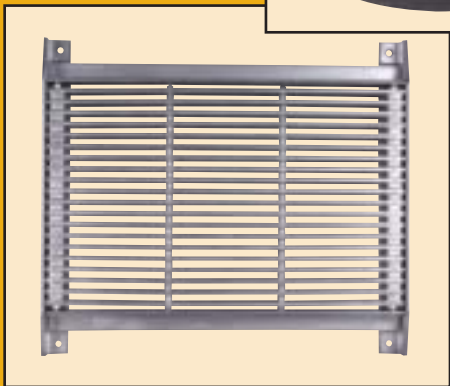

FIG. NO.PAGE	FIG. NO.PAGE	FIG. NO.PAGE	FIG. NO.PAGE	FIG. NO.PAGE
A-1591A-8	A-2155B-4	A-2420C-26	A-3630D-2	A-14608C-6
A-1601-BA-15	A-2157B-4	A-2421C-29	A-3631D-1	A-14609C-6
A-1602-BA-15	A-2159B-4	A-2422C-26	A-3650D-1	A-14610C-6
A-1603-BA-15	A-2161B-4	A-2423C-28	A-3655D-3	A-14612C-6
A-1662F-3	A-2163B-4	A-2424C-26	A-3656D-3	A-17551C-4
A-1663F-3	A-2165B-4	A-2426C-26	A-3658D-3	A-17552C-4
A-1664F-3	A-2167B-4	A-2430C-26	A-3659D-3	A-17553C-4
A-1671D-10	A-2169B-4	A-2431C-29	A-3885B-3	A-17555C-4
A-1672D-10	A-2221C-30	A-2432C-26	A-3900B-5	A-17556C-4
A-1673D-10	A-2222C-30	A-2434C-26	A-3901B-5	A-17557C-4
A-1675D-10	A-2223C-30	A-2436C-26	A-3902B-5	A-17558C-4
A-1677F-2	A-2224C-30	A-2440C-28	A-3903B-5	A-17560C-4
A-1680F-1	A-2232C-30	A-2442C-28	A-3904B-5	A-17562C-4
A-1690A-19	A-2233C-30	A-2446C-28	A-3905B-5	A-17563C-4
A-1850C-3	A-2234C-30	A-2448C-28	A-3911B-5	A-25838A-19
A-1855C-3	A-2235C-30	A-2754G-2	A-3912B-5	A-29502D-4
A-1856C-3	A-2236C-30	A-2755G-2	A-3913B-5	A-29503D-4
A-1980D-11	A-2237C-30	A-2810G-4	A-4011D-1	A-29504D-4
A-1981D-11	A-2238C-30	A-2811G-4	A-4012D-1	A-29505D-4
A-1982D-11	A-2239C-30	A-2812G-4	A-4013D-1	A-29506D-4
A-1983D-11	A-2239 ^{1/2}C-30	A-2815G-4	A-4022D-10	A-29508D-4
A-1984D-12	A-2240C-30	A-2840G-3	A-4280G-1	A-29510D-4
A-1985D-12	A-2251C-30	A-2851G-2	A-13701C-4	A-29512D-4
A-1986D-12	A-2252C-30	A-2852G-2	A-13702C-4	A-29602D-4
A-1999C-7	A-2273C-16	A-2853G-2	A-13704C-4	A-29603D-4
A-2001C-7	A-2281D-7	A-2920A-17	A-13705C-4	A-29604D-4
A-2002C-7	A-2282D-7	A-2922A-17	A-13706C-4	A-29605D-4
A-2005A-14	A-2283D-7	A-2925A-17	A-13707C-4	A-29606D-4
A-2010C-22	A-2291D-7	A-2984D-4	A-13708C-4	A-29607D-4
A-2011C-25	A-2292D-7	A-2986D-4	A-13709C-4	A-29608D-4
A-2012C-23	A-2293D-7	A-2988D-4	A-13902C-6	A-29610D-4
A-2014C-25	A-2301D-7	A-2989D-4	A-13903C-6	A-29612D-4
A-2015C-22	A-2302-BA-15	A-3000D-5	A-13905C-6	A-29625D-4
A-2017C-23	A-2303-BA-15	A-3004D-6	A-13906C-6	426A PATT#1A-6
A-2018C-25	A-2310C-9	A-3005D-6	A-13907C-6	PATT#2A-6
A-2020C-24	A-2320C-10	A-3007D-6	A-13908C-6	PATT#4A-6
A-2022C-24	A-2321C-10	A-3008D-6	A-13909C-6	PATT#5A-6
A-2025C-24	A-2322C-10	A-3009D-6	A-13910C-6	PATT#10 ..C-19
A-2027C-24	A-2323C-10	A-3308B-1	A-13911C-6	PATT#11 ..C-19
A-2040C-25	A-2324C-11	A-3309B-1	A-13912C-6	PATT#14 ..C-20
A-2080D-8	A-2325C-11	A-3316B-1	A-13913C-6	PATT#15 ..C-20
A-2088D-8	A-2326C-11	A-3320B-1	A-14411C-8	PATT#16 ..C-20
A-2089D-8	A-2327C-11	A-3321B-1	A-14412C-8	TYPE 8 ...D-16
A-2090D-9	A-2329C-12	A-3330G-3	A-14413C-8	TYPE 9 ...D-16
A-2091D-9	A-2330C-12	A-3340B-2	A-14414C-8	TYPE 11 ..D-16
A-2092D-9	A-2331C-12	A-3341B-2	A-14415C-8	
A-2093D-9	A-2332C-13	A-3342B-2	A-14416C-8	
A-2094D-9	A-2333C-13	A-3350B-2	A-14417C-8	
A-2095D-9	A-2334C-14	A-3351B-2	A-14418C-8	
A-2096D-8	A-2335C-14	A-3352B-2	A-14419C-8	
A-2097D-8	A-2336C-14	A-3380B-3	A-14421C-8	
A-2098D-8	A-2370G-2	A-3382B-3	A-14423C-8	
A-2099D-9	A-2400C-26	A-3383B-3	A-14424C-8	
A-2100D-8	A-2401C-29	A-3400B-3	A-14425C-8	
A-2121B-4	A-2402C-27	A-3420E-6	A-14601C-6	
A-2122B-4	A-2403C-28	A-3425E-6	A-14602C-6	
A-2130B-4	A-2404C-26	A-3430E-7	A-14603C-6	
A-2140B-4	A-2405C-29	A-3510E-8	A-14604C-6	
A-2151B-4	A-2410C-26	A-3540E-8	A-14605C-6	
A-2153B-4	A-2412C-26	A-3600E-8	A-14606C-6	

EVERYTHING IN IRON

AFCO

ESTABLISHED 1923



ALHAMBRA FOUNDRY COMPANY, LTD.

1147 MERIDIAN AVE., P.O. BOX 469, ALHAMBRA, CA 91802-0469

TEL 626 289-4294 FAX 626 289-3078 www.alhambrafoundry.com

© AFCO is a registered trademark of Alhambra Foundry Co. Ltd.