

STANDARD DRAWINGS FOR CONSTRUCTION

2021 EDITION

APPROVED: Anthony Howard

ANTHONY HOWARD
DIVISION ENGINEER
C. E. NO. 60785

3/29/2023 | 9:21:10 AM PDT

APPROVED: Mark Vanderzee

MARK VANDERZEE
DIVISION ENGINEER
S. E. NO. 3442

3/29/2023 | 8:10:12 AM PDT

LIST OF DRAWINGS

S-a-79	STANDARD METHOD OF INSTALLING SADDLES
S-a-86	STANDARD METHOD FOR CONNECTION TO PIPES AND STRUCTURES
S-a-201	STANDARD MANHOLE, TYPE "A"
S-a-202	STANDARD MANHOLE, TYPE "B"
S-a-203	STANDARD MANHOLE, TYPE "C"
S-a-204	STANDARD MANHOLE, TYPE "D"
S-a-205	STANDARD DROP MANHOLE
S-a-206	STANDARD MANHOLE, TYPE "E"
S-a-207	STANDARD 24" LOCKING MANHOLE FRAME AND COVER
S-a-208	STANDARD 24" PRESSURE MANHOLE FRAME AND COVER
S-a-209	STANDARD MANHOLE STEP
S-a-210	STANDARD TRAP MANHOLE BASE
S-a-211	STANDARD TRAP CASTING
S-a-212	STANDARD CRADLES AND ENCASEMENTS
S-a-213	STANDARD "T" SADDLE
S-a-214	STANDARD CHIMNEY PIPE
S-a-215	STANDARD 36" MANHOLE FRAME AND COVER
S-a-216	STANDARD HOUSE CONNECTION GAS TRAP
S-a-217	STANDARD CONCRETE PIPE SUPPORT
S-a-218	STANDARD ABANDONMENT OF EXISTING MANHOLES TYPE "A" OR "D"
S-a-219	STANDARD RECONSTRUCTION OF BRICK MANHOLES
S-a-220	STANDARD PULL RING
S-a-221	STANDARD PROJECT SIGN
S-a-222	STANDARD TEMPORARY PIPE SUPPORT
S-a-223	STANDARD 30" MANHOLE FRAME AND COVER
S-a-224	STANDARD PIPE BARREL
S-a-225	STANDARD CONCRETE COLLAR
S-a-226	STANDARD 36" MANHOLE FRAME WITH 30" COVER
S-a-227	STANDARD CONCRETE BEAM FOR HOUSE CONNECTIONS
S-a-228	STANDARD 24" TRAFFIC MANHOLE FRAME AND COVER
S-a-229	STANDARD 36" PRESSURE MANHOLE FRAME AND COVER
S-a-230	STANDARD LIFTING EYE
S-a-231	STANDARD RECESSED PLATE BRIDGING
S-a-232	STANDARD NON-RECESSED PLATE BRIDGING
S-a-233	STANDARD CLEANOUT

NOTE:

HOLES IN EXISTING PIPE SHALL BE MADE BY CORE DRILLING PER S-a-86.

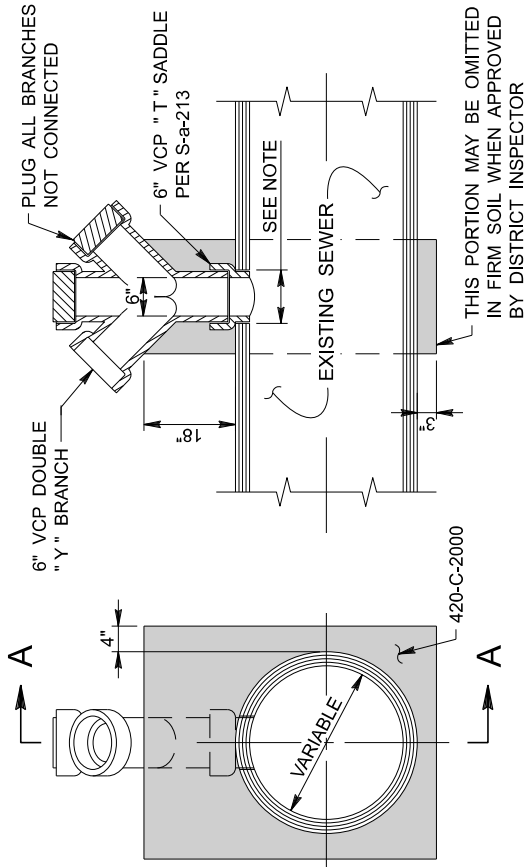
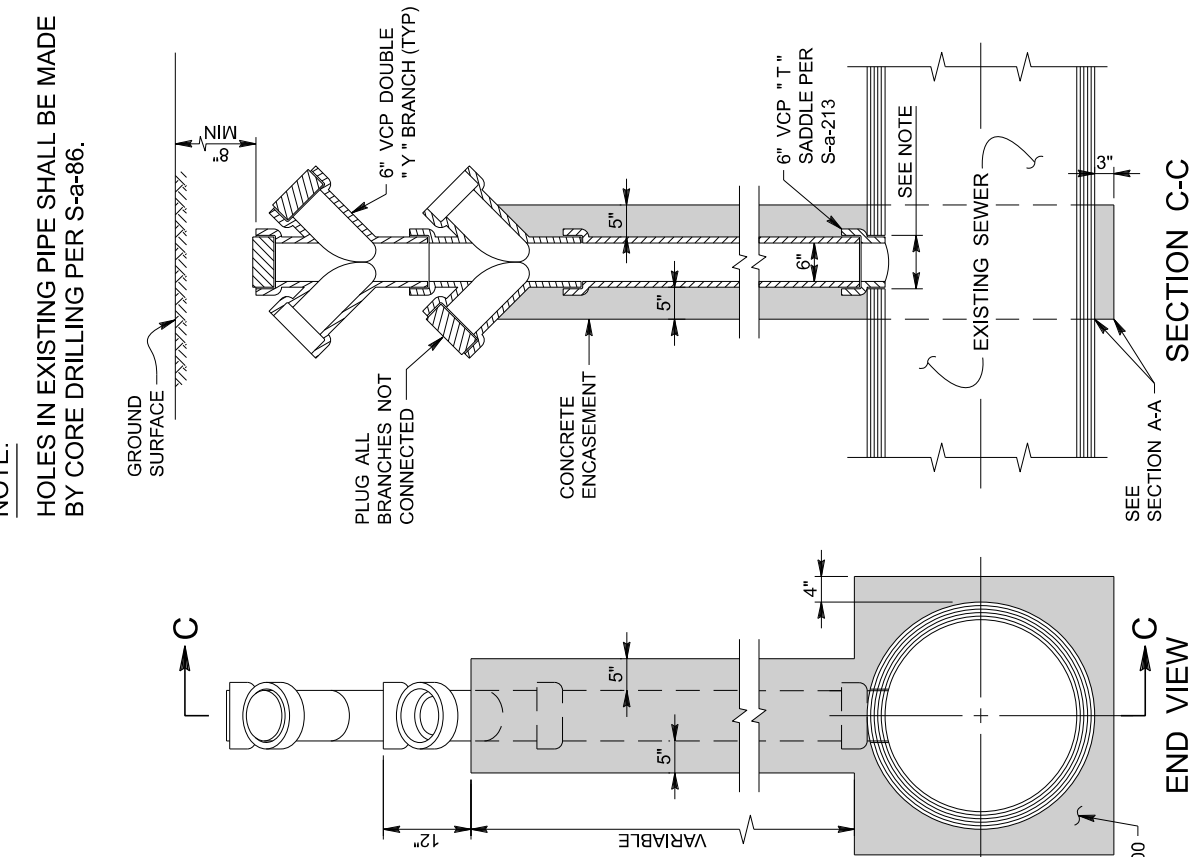

SECTION A-A

END VIEW

STANDARD "T" SADDLE WITH DOUBLE "Y" (SHALLOW LINE)

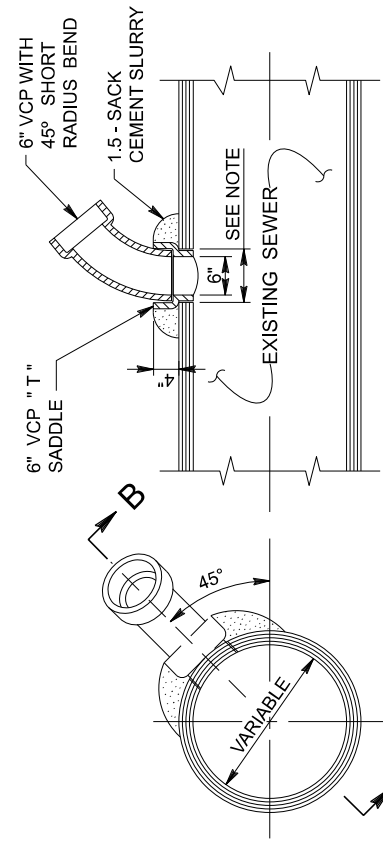

SECTION B-B

END VIEW

"T" SADDLE WITH SHORT RADIUS BEND

STANDARD "T" SADDLE WITH DOUBLE "Y" (DEEP LINE)

THIS DRAWING DOES NOT APPLY TO CONNECTIONS TO LINED PIPE

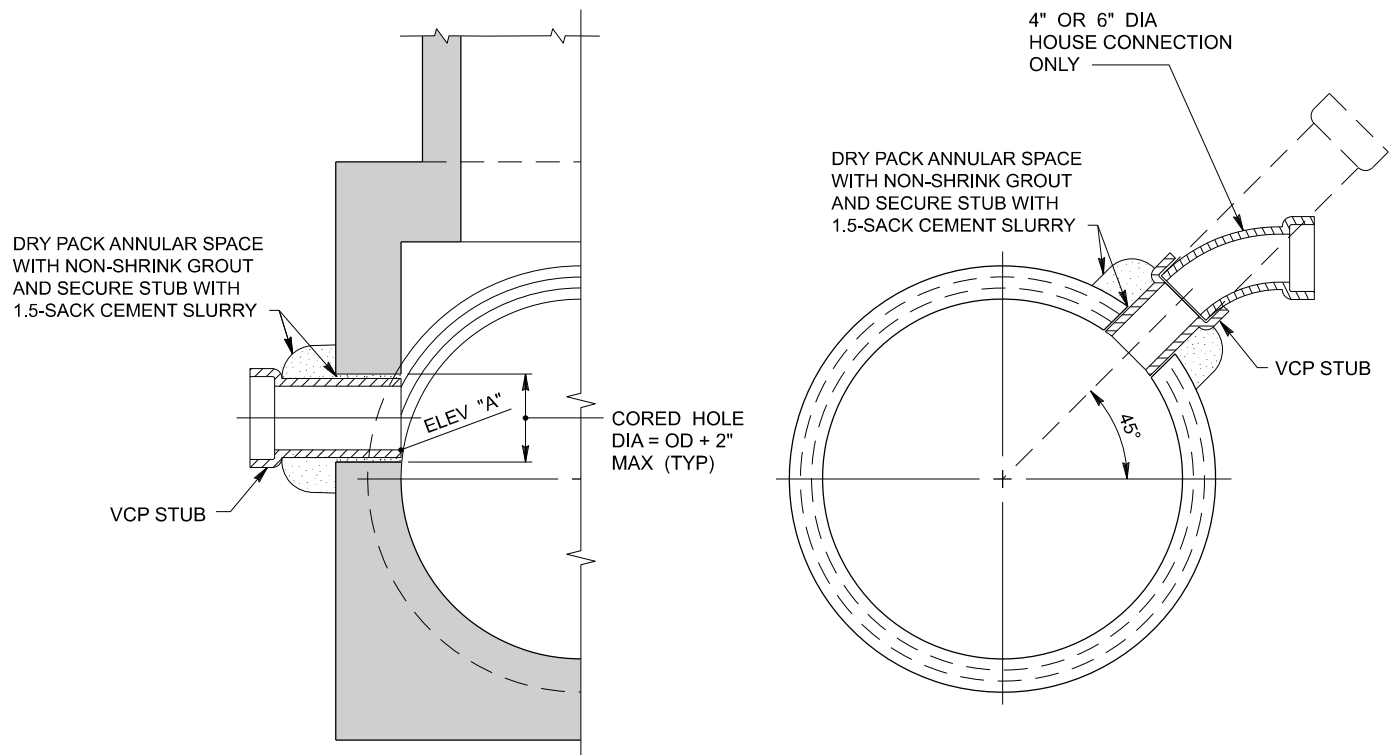

CONNECTION TO REINFORCED CONCRETE STRUCTURE

CONNECTION TO RCP (ALL SIZES) OR NRCP & VCP 21" OR LARGER

NOTES:

1. ELEVATION "A" SHALL BE AS SHOWN ON SEWER DRAWINGS APPROVED BY DISTRICTS' ENGINEER.
2. HOUSE CONNECTION TO VCP STUB SHALL BE AS SHOWN ON S-a-79 EXCEPT AS SHOWN HEREON.
3. THE CORED HOLE SHALL BE MADE WITH EQUIPMENT SPECIALLY DESIGNED TO CUT A SMOOTH HOLE WITHOUT SPALLING OR DAMAGE TO THE REINFORCING STEEL, PIPE OR STRUCTURE.
4. THE CORING OF THE HOLE AND THE PLACING OF THE STUB SHALL BE DONE IN THE PRESENCE OF THE DISTRICTS' INSPECTOR.
5. NO CONNECTION SHALL BE MADE TO THE STUB UNTIL DISTRICTS' INSPECTOR HAS APPROVED THE STUB.
6. VCP STUB SHALL BE 2' IN LENGTH.

THIS DRAWING DOES NOT APPLY TO CONNECTIONS TO LINED PIPES OR STRUCTURES

COUNTY SANITATION DISTRICTS OF LOS ANGELES COUNTY
OFFICE OF CHIEF ENGINEER

ROBERT FERRANTE
CHIEF ENGINEER

STANDARD METHOD FOR CONNECTION TO PIPES AND STRUCTURES

STANDARD DRAWING
2021 EDITION

S - a - 8 6

SHEET 1 OF 12

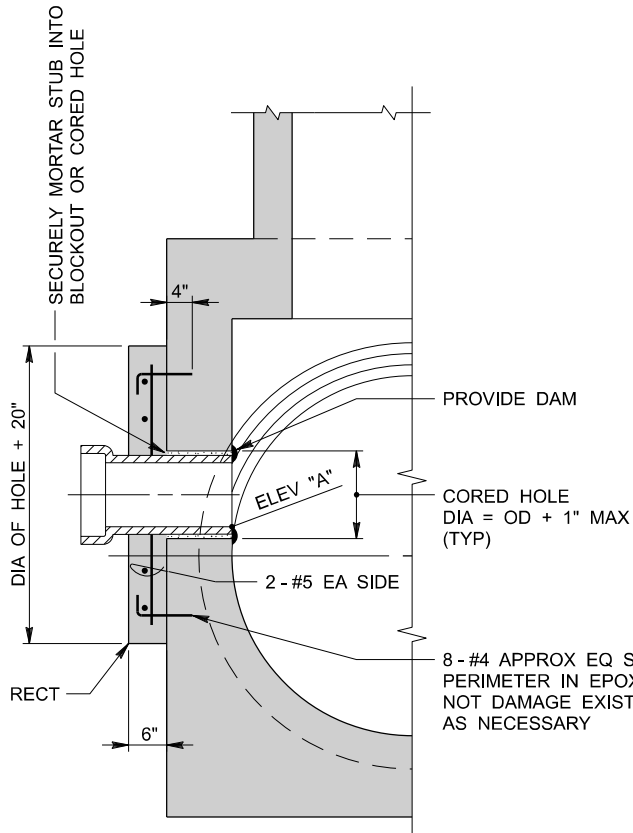

**CONNECTION TO REINFORCED
CONCRETE STRUCTURE**

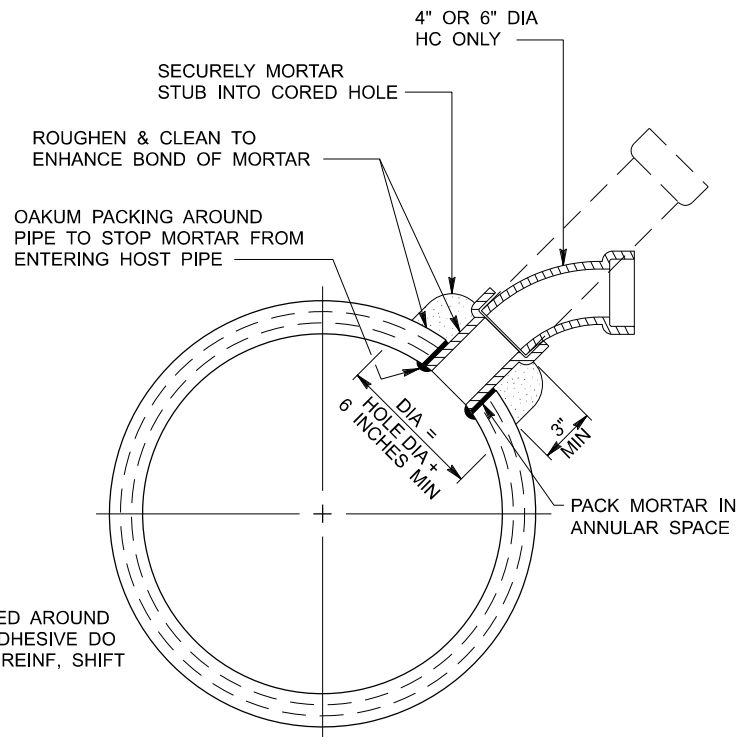

**CONNECTION TO RCP 21" &
NRCP MIN 21" & VCP 21" OR LARGER**

NOTES:

1. ELEVATION "A" FOR LATERAL SEWER CONNECTIONS SHALL BE AS SHOWN ON APPROVED LATERAL SEWER DRAWINGS.
2. HOUSE CONNECTION TO THE PIPE SHALL BE AS SHOWN ON S-a-79 EXCEPT AS SHOWN HEREON.
3. THE CORED HOLE SHALL BE MADE WITH EQUIPMENT SPECIFICALLY DESIGNED TO CUT A SMOOTH HOLE WITHOUT SPALLING OR DAMAGE TO THE REINFORCING STEEL, PIPE OR STRUCTURE.
4. THE CORING OF THE HOLE AND THE PLACING OF THE STUB SHALL BE DONE IN THE PRESENCE OF THE DISTRICT INSPECTOR.
5. NO CONNECTION SHALL BE MADE TO THE STUB UNTIL DISTRICT INSPECTOR HAS APPROVED THE STUB.
6. MORTAR SHALL BE PACKAGED, PREMIXED, NON-SAG POLYMER-MODIFIED, CEMENT BASED. MORTAR PRODUCT SHALL BE SUBMITTED FOR DISTRICTS REVIEW AND APPROVAL.

**THIS DRAWING DOES NOT APPLY TO CONNECTIONS TO
LINED PIPES OR STRUCTURES**

COUNTY SANITATION DISTRICTS OF LOS ANGELES COUNTY
OFFICE OF CHIEF ENGINEER

ROBERT FERRANTE
CHIEF ENGINEER

**STANDARD METHOD FOR CONNECTION
TO PIPES AND STRUCTURES**

STANDARD DRAWING
2021 EDITION
S - a - 8 6
SHEET 2 OF 12

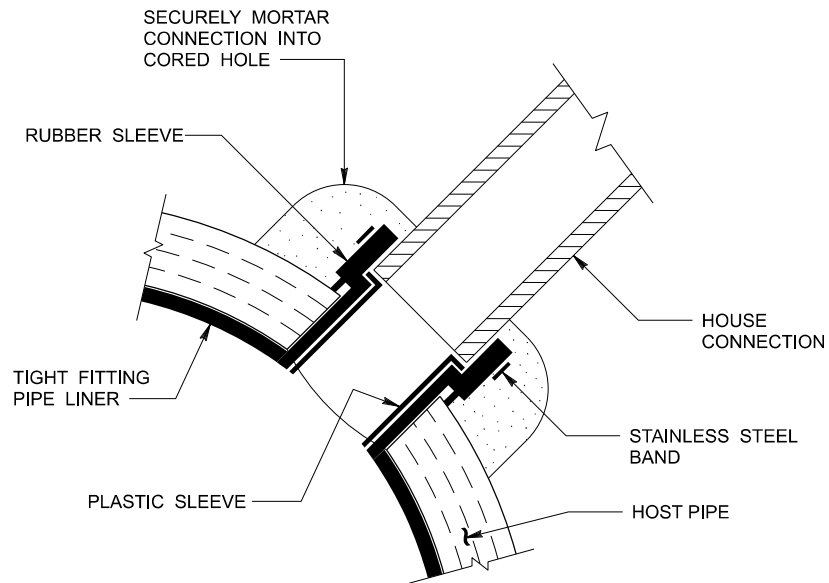

OPTION 1

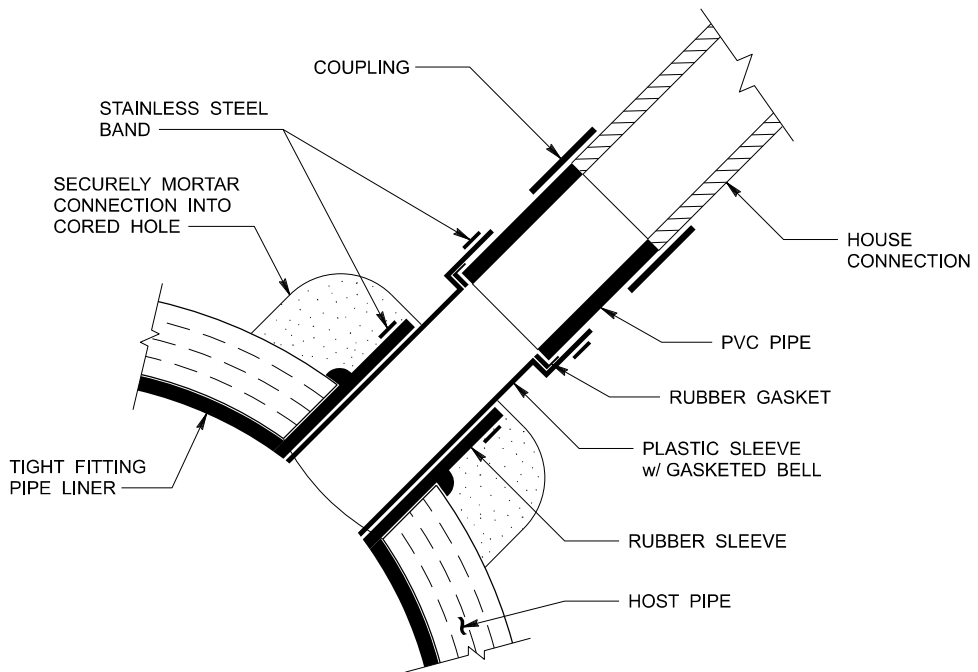

OPTION 2

FOR NOTES, SEE SHEET 4 OF 12

**NEW CONNECTION TO PIPE
WITH TIGHT FITTING PIPE LINER**

COUNTY SANITATION DISTRICTS OF LOS ANGELES COUNTY
OFFICE OF CHIEF ENGINEER

ROBERT FERRANTE
CHIEF ENGINEER

**STANDARD METHOD FOR CONNECTION
TO PIPES AND STRUCTURES**

STANDARD DRAWING
2021 EDITION
S - a - 8 6
SHEET 3 OF 12

NOTES:

1. MAXIMUM ALLOWABLE CONNECTION SHALL BE 6-INCH.
2. CONTRACTOR SHALL ONLY UTILIZE THE OPTION(S) AS SPECIFIED IN THE SPECIAL PROVISIONS.
3. THE CORED HOLE SHALL BE MADE WITH EQUIPMENT RECOMMENDED BY THE MANUFACTURER OF THE CONNECTION AND DESIGNED TO CUT A SMOOTH HOLE WITHOUT SPALLING OR DAMAGE TO ANY REINFORCING STEEL, IF PRESENT OR THE PIPE.
4. THE CORING OF THE HOLE AND THE PLACING OF THE CONNECTION SHALL BE PER MANUFACTURER'S RECOMMENDATIONS AND SHALL BE DONE IN THE PRESENCE OF THE DISTRICT'S INSPECTOR.
5. THE RUBBER SLEEVE SHALL BE ORDERED TO COVER THE ENTIRE CORED HOLE AND PIPE LINER.
6. THE RUBBER SLEEVE AND THE PLASTIC INSERT SHALL BE PLACED SO THAT BOTH ARE FLUSH WITH THE INSIDE WALL OF THE PIPE LINER.
7. NO CONNECTIONS SHALL BE MADE TO THE STUB UNTIL THE DISTRICT'S INSPECTOR HAS APPROVED THE STUB.
8. CONTRACTS FOR OPTIONS:

OPTION 1: JOINTS TAP-N-TEE
10699 HICKSON STREET, SUITE 20
EL MONTE, CA 91713
(626) 448-2100

OPTION 2: INSERTA FITTINGS COMPANY
3707 24TH AVENUE
FOREST GROVE, OR 97116
(503) 357-2110

NEW CONNECTION TO PIPE
WITH TIGHT FITTING PIPE LINER

COUNTY SANITATION DISTRICTS OF LOS ANGELES COUNTY
OFFICE OF CHIEF ENGINEER

ROBERT FERRANTE
CHIEF ENGINEER

STANDARD METHOD FOR CONNECTION
TO PIPES AND STRUCTURES

STANDARD DRAWING
2021 EDITION
S - a - 8 6
SHEET 4 OF 12

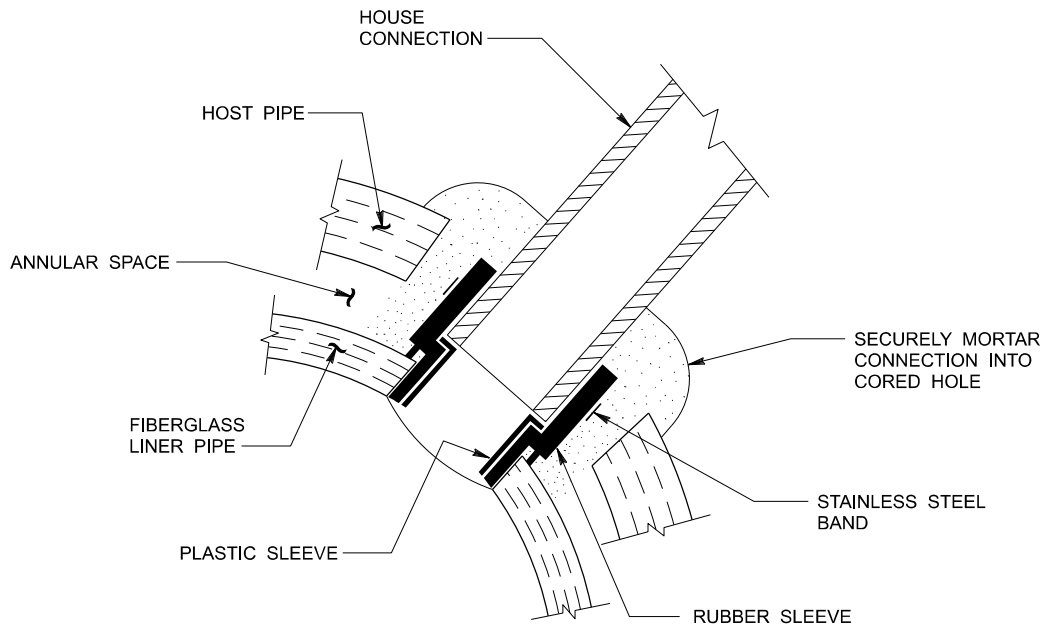

OPTION 1

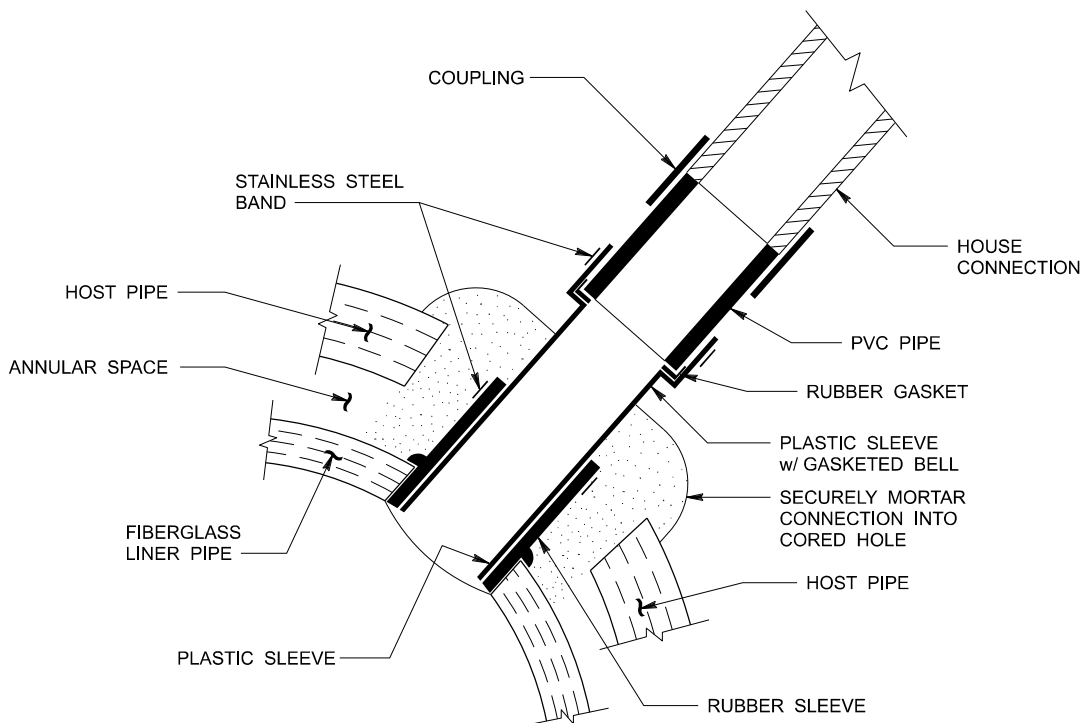

OPTION 2

FOR NOTES, SEE SHEET 6 OF 12

**RECONNECTING EXISTING HOUSE CONNECTION
TO PIPE WITH FIBERGLASS LINER PIPE**

COUNTY SANITATION DISTRICTS OF LOS ANGELES COUNTY
OFFICE OF CHIEF ENGINEER

ROBERT FERRANTE
CHIEF ENGINEER

**STANDARD METHOD FOR CONNECTION
TO PIPES AND STRUCTURES**

STANDARD DRAWING
2021 EDITION
S - a - 8 6
SHEET 5 OF 12

NOTES:

1. CONTRACTOR SHALL ONLY UTILIZE THE OPTION(S) AS SPECIFIED IN THE SPECIAL PROVISIONS.
2. THE CONTRACTOR SHALL CORE OR BREAK-AWAY AN OPENING IN THE HOST PIPE IN ORDER TO CORE THE LINER PIPE AND PROVIDE ADEQUATE SPACE FOR THE CONNECTION AS RECOMMENDED BY THE MANUFACTURER OF THE CONNECTION.
3. THE CORED HOLE SHALL BE MADE WITH EQUIPMENT RECOMMENDED BY THE MANUFACTURER OF THE CONNECTION AND DESIGNED TO CUT A SMOOTH HOLE WITHOUT SPALLING OR DAMAGE TO ANY REINFORCING STEEL, IF PRESENT OR THE PIPE.
4. THE CORING OF THE HOLE AND THE PLACING OF THE CONNECTION SHALL BE PER MANUFACTURER'S RECOMMENDATIONS AND SHALL BE DONE IN THE PRESENCE OF THE DISTRICT'S INSPECTOR.
5. THE RUBBER SLEEVE SHALL BE ORDERED TO COVER THE ENTIRE CORED HOLE AND PIPE LINER.
6. THE RUBBER SLEEVE AND THE PLASTIC INSERT SHALL BE PLACED SO THAT BOTH ARE FLUSH WITH THE INSIDE WALL OF THE PIPE LINER.
7. THE CONTRACTOR SHALL NOT GROUT THE ANNULAR SPACE UNTIL THE CONNECTION IS MADE BETWEEN THE LINER PIPE AND THE HOUSE CONNECTIONS.
8. CONTRACTS FOR OPTIONS:

OPTION 1: JOINTS TAP-N-TEE
10699 HICKSON STREET, SUITE 20
EL MONTE, CA 91713
(626) 448-2100

OPTION 2: INSERTA FITTINGS COMPANY
3707 24TH AVENUE
FOREST GROVE, OR 97116
(503) 357-2110

**RECONNECTING EXISTING HOUSE CONNECTION
TO PIPE WITH FIBERGLASS LINER PIPE**

COUNTY SANITATION DISTRICTS OF LOS ANGELES COUNTY
OFFICE OF CHIEF ENGINEER

ROBERT FERRANTE
CHIEF ENGINEER

**STANDARD METHOD FOR CONNECTION
TO PIPES AND STRUCTURES**

STANDARD DRAWING
2021 EDITION

S - a - 8 6

SHEET 6 OF 12

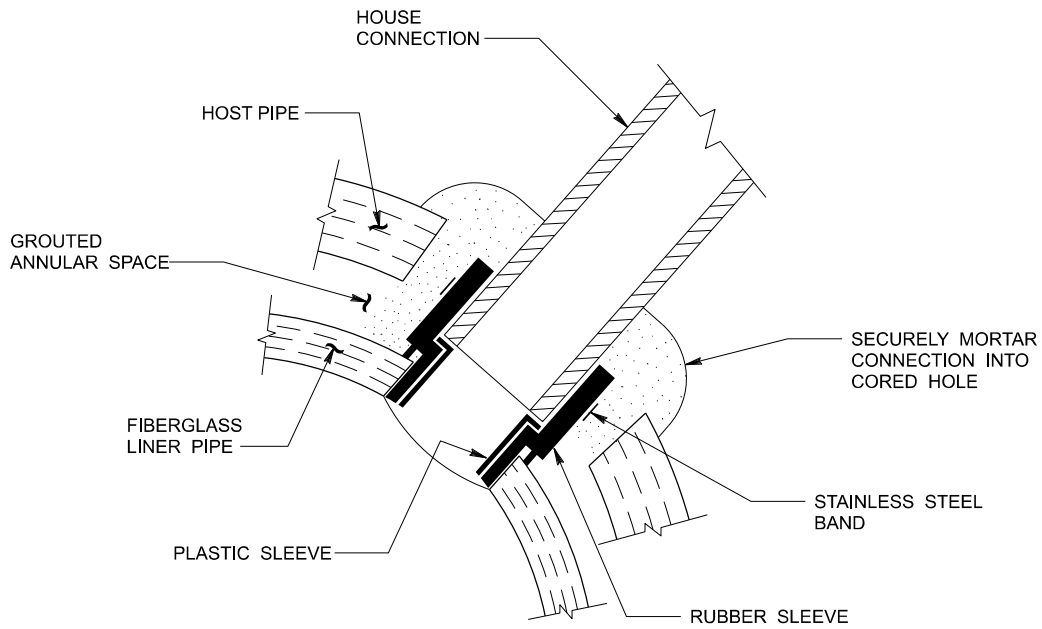

OPTION 1

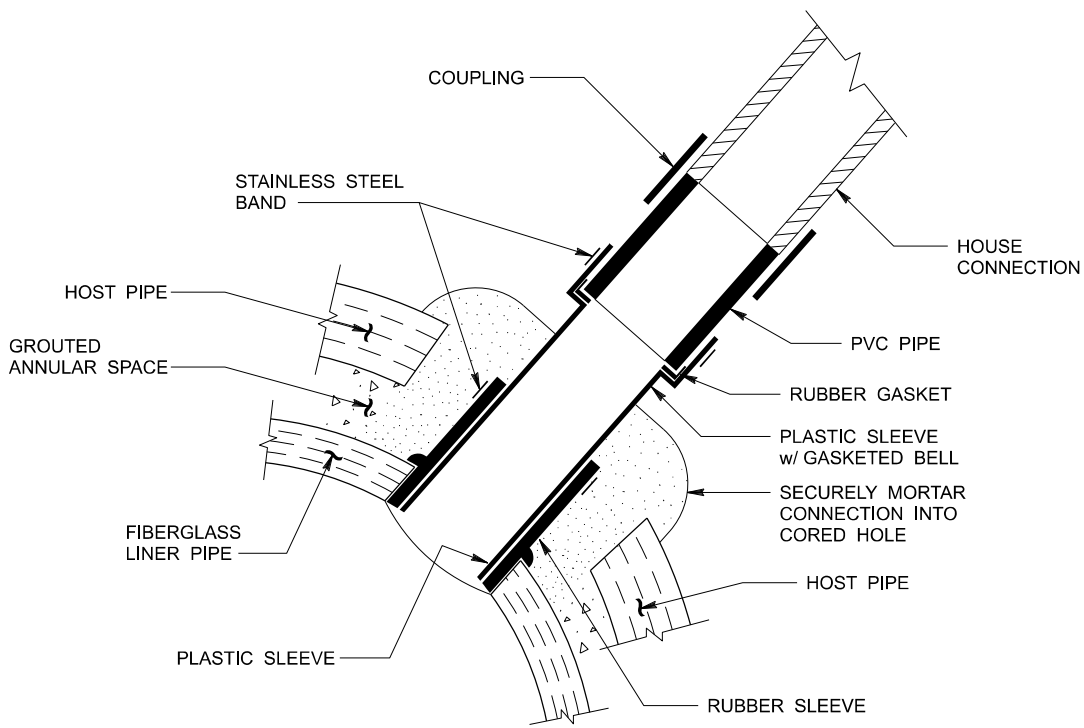

OPTION 2

FOR NOTES, SEE SHEET 8 OF 12

**NEW CONNECTION TO PIPE
WITH FIBERGLASS LINER PIPE**

COUNTY SANITATION DISTRICTS OF LOS ANGELES COUNTY
OFFICE OF CHIEF ENGINEER

ROBERT FERRANTE
CHIEF ENGINEER

**STANDARD METHOD FOR CONNECTION
TO PIPES AND STRUCTURES**

STANDARD DRAWING
2021 EDITION
S - a - 8 6
SHEET 7 OF 12

NOTES:

1. MAXIMUM ALLOWABLE CONNECTION SHALL BE 6-INCH.
2. CONTRACTOR SHALL ONLY UTILIZE THE OPTION(S) AS SPECIFIED IN THE SPECIAL PROVISIONS.
3. THE CONTRACTOR SHALL CORE OR BREAK-AWAY AN OPENING IN THE HOST PIPE AND GROUTED ANNULAR SPACE IN ORDER TO CORE THE SLIPLINED PIPE AND PROVIDE ADEQUATE SPACE FOR THE CONNECTION AS RECOMMENDED BY THE MANUFACTURER OF THE CONNECTION.
4. THE CORED HOLE SHALL BE MADE WITH EQUIPMENT RECOMMENDED BY THE MANUFACTURER OF THE CONNECTION AND DESIGNED TO CUT A SMOOTH HOLE WITHOUT SPALLING OR DAMAGE TO ANY REINFORCING STEEL, IF PRESENT OR THE PIPE.
5. THE CORING OF THE HOLE AND THE PLACING OF THE CONNECTION SHALL BE PER MANUFACTURER'S RECOMMENDATIONS AND SHALL BE DONE IN THE PRESENCE OF THE DISTRICT'S INSPECTOR.
6. THE RUBBER SLEEVE SHALL BE ORDERED TO COVER THE ENTIRE CORED HOLE AND PIPE LINER.
7. THE RUBBER SLEEVE AND THE PLASTIC INSERT SHALL BE PLACED SO THAT BOTH ARE FLUSH WITH THE INSIDE WALL OF THE PIPE LINER.
8. THE MORTAR USED TO SECURE THE INSTALLED CONNECTION SHALL ALSO FILL THE ANNULAR SPACE GROUT REMOVED FOR INSTALLATION OF THE CONNECTION.
9. CONTRACTS FOR OPTIONS:

OPTION 1: JOINTS TAP-N-TEE
10699 HICKSON STREET, SUITE 20
EL MONTE, CA 91713
(626) 448-2100

OPTION 2: INSERTA FITTINGS COMPANY
3707 24TH AVENUE
FOREST GROVE, OR 97116
(503) 357-2110

**NEW CONNECTION TO PIPE
WITH FIBERGLASS LINER PIPE**

COUNTY SANITATION DISTRICTS OF LOS ANGELES COUNTY
OFFICE OF CHIEF ENGINEER

ROBERT FERRANTE
CHIEF ENGINEER

**STANDARD METHOD FOR CONNECTION
TO PIPES AND STRUCTURES**

STANDARD DRAWING
2021 EDITION
S - a - 8 6
SHEET 8 OF 12

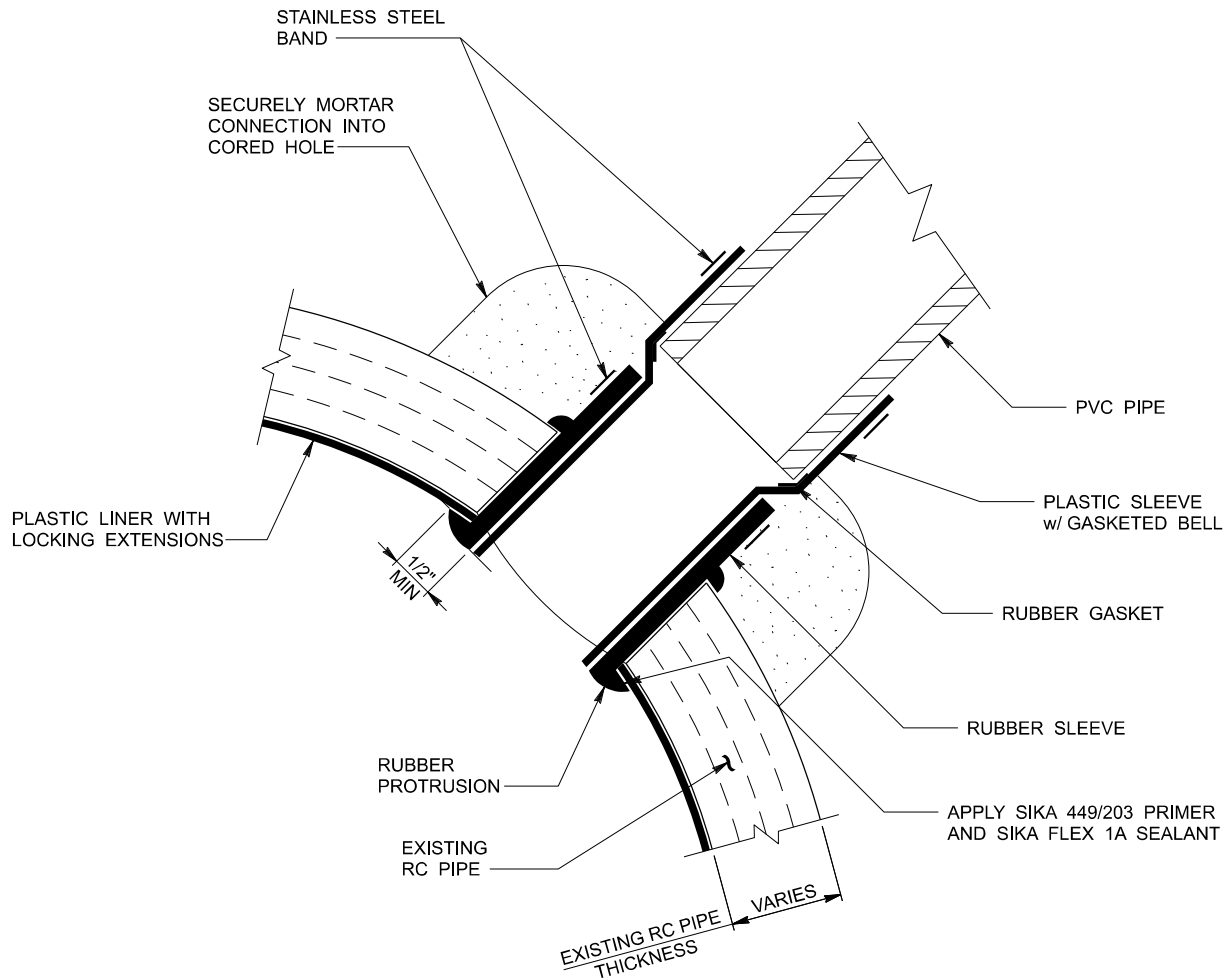

FOR NOTES, SEE SHEET 10 OF 12

NEW CONNECTION TO EXISTING REINFORCED CONCRETE PIPE WITH PLASTIC LINER WITH LOCKING EXTENSIONS

COUNTY SANITATION DISTRICTS OF LOS ANGELES COUNTY
OFFICE OF CHIEF ENGINEER

ROBERT FERRANTE
CHIEF ENGINEER

STANDARD METHOD FOR CONNECTION TO PIPES AND STRUCTURES

STANDARD DRAWING
2021 EDITION
S - a - 8 6
SHEET 9 OF 12

NOTES:

1. MAXIMUM ALLOWABLE CONNECTION SHALL BE 6-INCH.
2. THE CORED HOLE SHALL BE MADE WITH EQUIPMENT RECOMMENDED BY THE MANUFACTURER OF THE CONNECTION AND DESIGNED TO CUT A SMOOTH HOLE WITHOUT SPALLING OR DAMAGE TO ANY REINFORCING STEEL, PIPE OR PVC T-LOCK LINER.
3. THE THICKNESS OF THE CORED PIPE AND THE PVC LINER SHALL BE MEASURED AND CONVEYED TO THE MANUFACTURER OF THE CONNECTION FOR THE FABRICATION OF THE CONNECTION.
4. PRIOR TO INSTALLING THE CONNECTION, THE PVC LINER AROUND THE PIPE AT THE CORED HOLE AND THE WALLS OF THE CORED HOLE WILL BE CLEANED PER MANUFACTURER'S RECOMMENDATION AND EACH OF THESE SURFACES SHALL BE COATED WITH A THIN LAYER OF SIKA 429 PRIMER AND SIKA 1A SEALANT OR APPROVED EQUAL AS DIRECTED BY THE MANUFACTURER.
5. THE CONNECTION SHALL BE INSTALLED PER MANUFACTURER'S RECOMMENDATIONS AND SHALL SECURELY ENCAPSULATE THE PVC LINER AND WALL THICKNESS BETWEEN THE TWO RUBBER PROTRUSIONS OF THE CONNECTION. THIS SHALL BE VERIFIED BY USE OF A MIRROR SYSTEM AND LIGHTS PROVIDED BY THE CONTRACTOR.
6. THE CONTRACTOR SHALL NOT MORTAR AROUND THE CONNECTION OR MAKE A CONNECTION TO THE NEW STUB UNTIL THE DISTRICT'S INSPECTOR HAS APPROVED THE CONNECTION.
7. THE RUBBER AND PLASTIC CONNECTION SHALL BE MANUFACTURED BY INSERTA FITTINGS COMPANY OR APPROVED EQUAL.
8. CONTRACT FOR CONNECTOR:

INSERTA FITTINGS COMPANY
3707 24TH AVENUE
FOREST GROVE, OR 97116
(503) 357-2110

**NEW CONNECTION TO EXISTING REINFORCED CONCRETE PIPE
WITH PLASTIC LINER WITH LOCKING EXTENSIONS**

COUNTY SANITATION DISTRICTS OF LOS ANGELES COUNTY
OFFICE OF CHIEF ENGINEER

ROBERT FERRANTE
CHIEF ENGINEER

**STANDARD METHOD FOR CONNECTION
TO PIPES AND STRUCTURES**

STANDARD DRAWING
2021 EDITION
S - a - 8 6
SHEET 10 OF 12

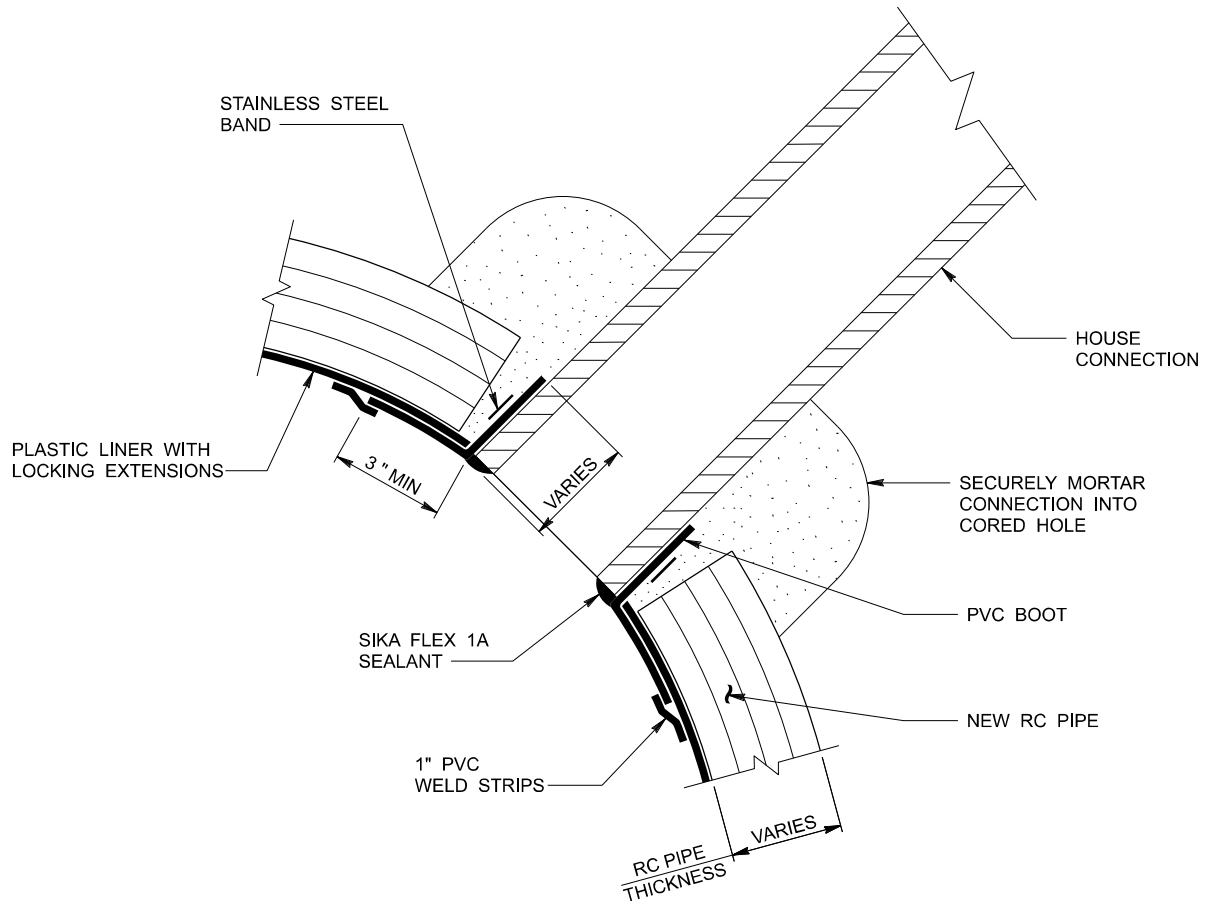

FOR NOTES, SEE SHEET 12 OF 12

**CONNECTION TO NEW REINFORCED CONCRETE PIPE
WITH PLASTIC LINER WITH LOCKING EXTENSIONS**

COUNTY SANITATION DISTRICTS OF LOS ANGELES COUNTY
OFFICE OF CHIEF ENGINEER

ROBERT FERRANTE
CHIEF ENGINEER

**STANDARD METHOD FOR CONNECTION
TO PIPES AND STRUCTURES**

STANDARD DRAWING
2021 EDITION
S - a - 8 6
SHEET 11 OF 12

NOTES:

1. MAXIMUM ALLOWABLE CONNECTION SHALL BE 6-INCH.
2. THE CORED HOLE SHALL BE APPROXIMATELY 3-INCH GREATER THAN OUTSIDE DIAMETER OF THE HOUSE CONNECTION PIPE. THE CORED HOLE SHALL BE DESIGNED TO CUT A HOLE WITH MINIMUM DAMAGE TO THE REINFORCING STEEL, PIPE OR PLASTIC LINER.
3. PRIOR TO INSTALLING THE PVC BOOT ON THE CONNECTION, THE PLASTIC LINER AROUND THE PIPE AT THE CORED HOLE SHALL BE CLEANED PER THE PLASTIC LINER MANUFACTURER'S RECOMMENDATION. THE END OF THE HOUSE CONNECTION SHALL BE SEALED TO THE PVC BOOT WITH SIKA 449/203 PRIMER AND SIKA FLEX 1A SEALANT.
4. THE PVC BOOT SHALL BE ORDERED SO IT WILL FIT SNUGLY TO THE OUTSIDE WALL OF THE HOUSE CONNECTION.
5. THE PVC BOOT AND WELD STRIPS SHALL BE INSTALLED AND TESTED FOR HOLIDAYS PER THE PLASTIC LINER MANUFACTURER'S RECOMMENDATION.
6. THE HOUSE CONNECTION PIPE SHALL BE CENTERED IN THE CORED HOLE AND PLACED SO IT IS FLUSH WITH THE INSIDE WALL OF THE RC PIPE.

CONNECTION TO NEW REINFORCED CONCRETE PIPE
WITH PLASTIC LINER WITH LOCKING EXTENSIONS

COUNTY SANITATION DISTRICTS OF LOS ANGELES COUNTY
OFFICE OF CHIEF ENGINEER

ROBERT FERRANTE
CHIEF ENGINEER

STANDARD METHOD FOR CONNECTION
TO PIPES AND STRUCTURES

STANDARD DRAWING
2021 EDITION
S - a - 8 6
SHEET 12 OF 12

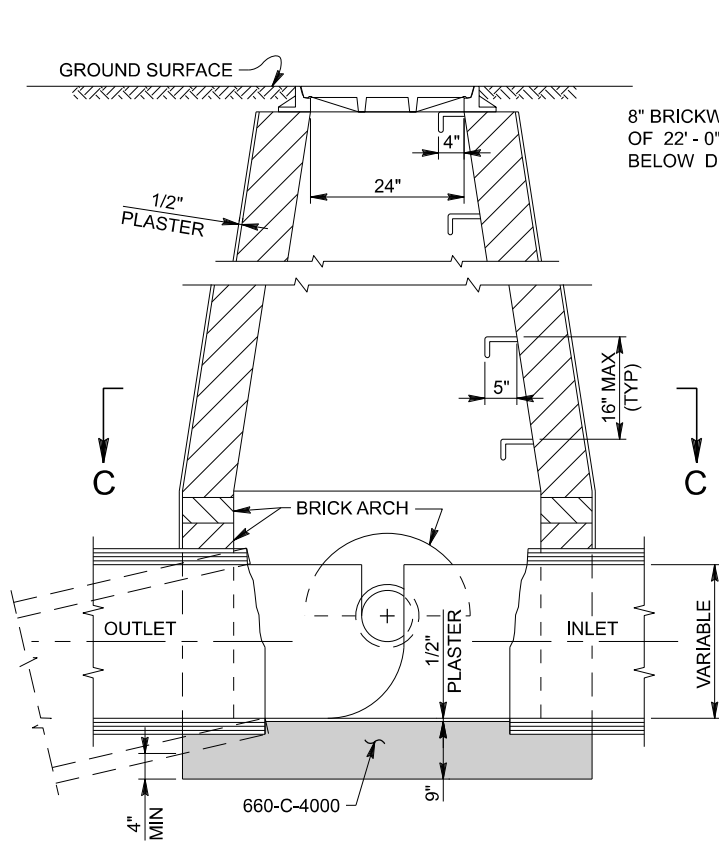

SECTION A-A

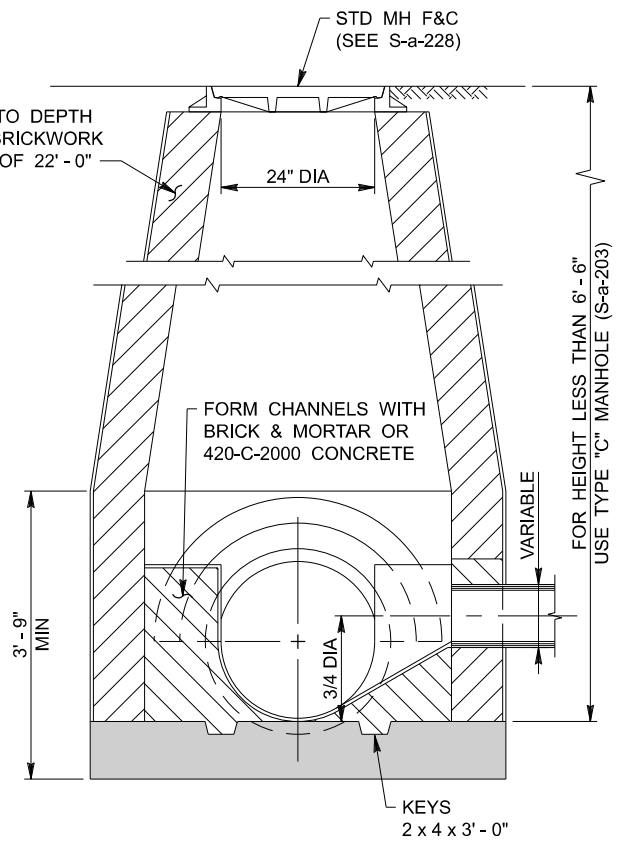

SECTION B-B

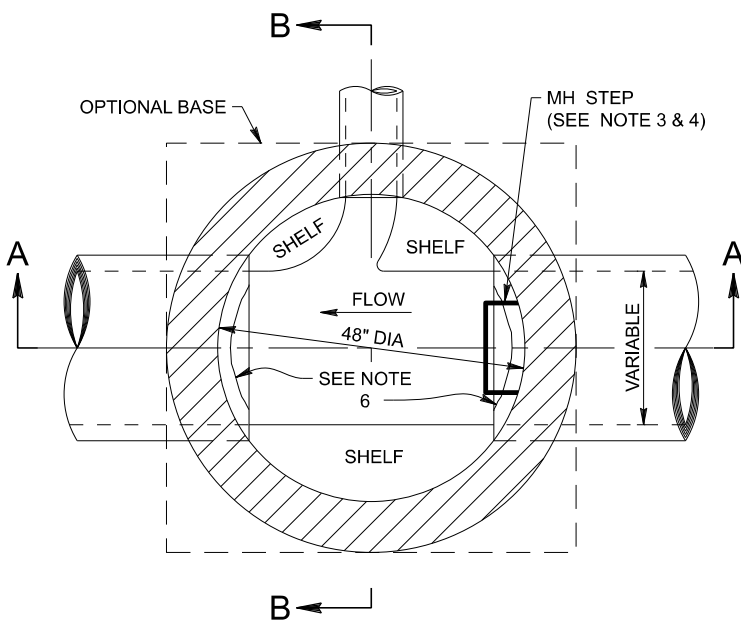

PLAN SECTION C-C

NOTES:

1. FOR 15" SEWERS AND LARGER, TURN 8" ARCH OVER PIPE.
2. FOR 12" SEWERS AND SMALLER, TURN 4" ARCH OVER PIPE.
3. THE LOWEST MANHOLE STEP SHALL BE PLACED NOT LESS THAN 8" OR MORE THAN 24" ABOVE SHELF.
4. THE UPPER MANHOLE STEP SHALL BE PLACED BETWEEN THE TOP OF MANHOLE AND MANHOLE COVER FRAME AND SHALL PROJECT NOT MORE THAN 4" INSIDE MANHOLE. ALL OTHERS SHALL PROJECT 5".
5. FOR LAYING BRICK OR PLASTERING, THE MORTAR SHALL CONFORM WITH SECTION 201-5.1 (CLASS "D") OF THE STANDARD SPECIFICATIONS.
6. FOR 30" PIPE, THE TOP PORTION OF THE PIPES WITHIN THE MANHOLE SHALL BE CUT OUT TO PROVIDE A CIRCULAR OPENING BETWEEN THE PIPE ENDS OF NOT LESS THAN 42". THE CUT EDGES SHALL BE PLASTERED SMOOTH WITH CEMENT MORTAR FOR CONCRETE PIPE AND EPOXY FOR CLAY PIPE. THE CIRCULAR OPENING SHALL BE CUT PRIOR TO INSTALLATION OF THE RISER SECTIONS.

FOR 8" TO 30" PIPE

COUNTY SANITATION DISTRICTS OF LOS ANGELES COUNTY
OFFICE OF CHIEF ENGINEER

ROBERT FERRANTE
CHIEF ENGINEER

STANDARD MANHOLE, TYPE "A"

STANDARD DRAWING
2021 EDITION
S - a - 2 0 1
SHEET 1 OF 1

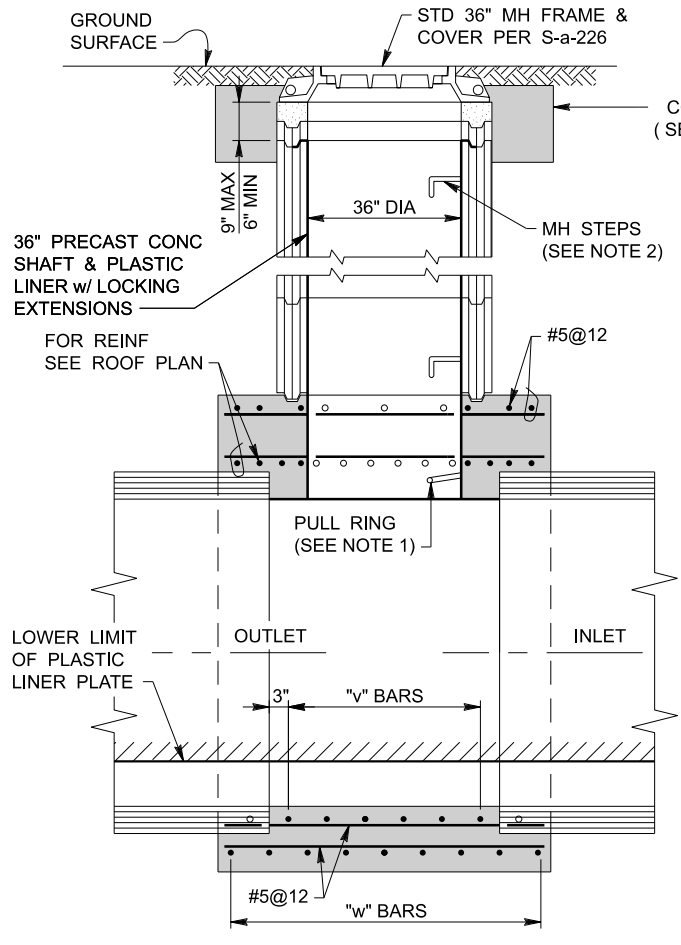

LONGITUDINAL SECTION

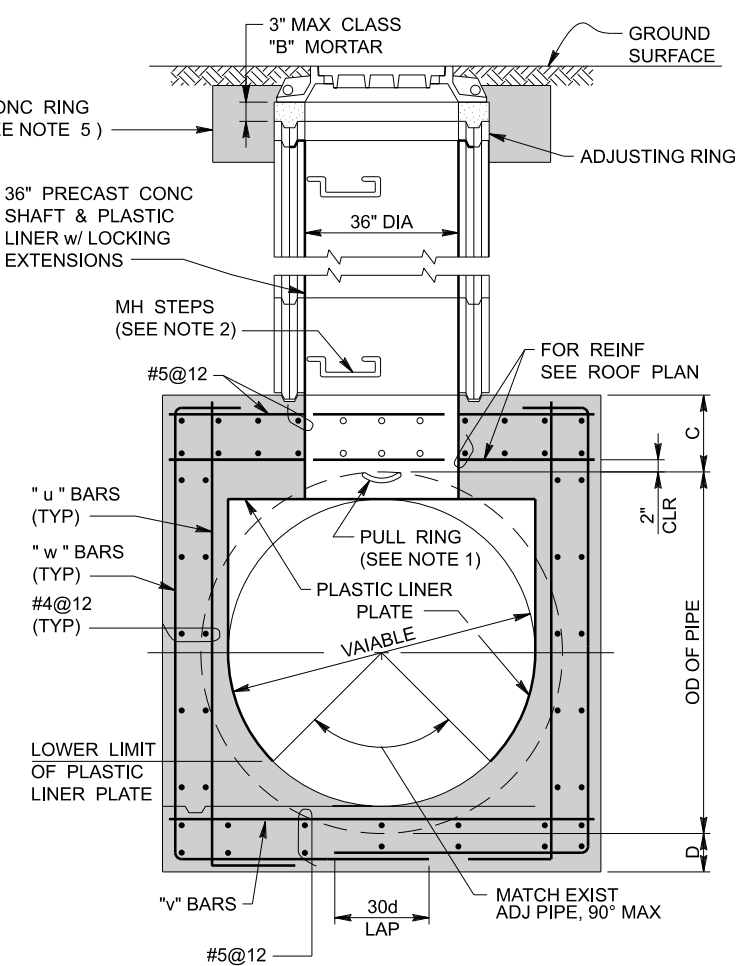

CROSS SECTION

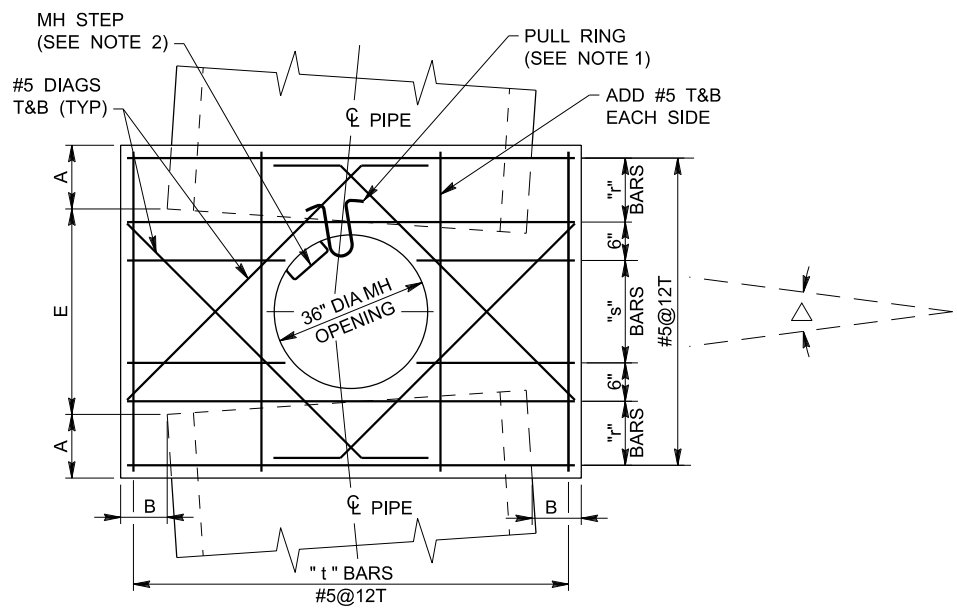

**ROOF PLAN 0° TO 15°
FOR 48" TO 96" PIPE**

COUNTY SANITATION DISTRICTS OF LOS ANGELES COUNTY
OFFICE OF CHIEF ENGINEER

ROBERT FERRANTE
CHIEF ENGINEER

STANDARD MANHOLE, TYPE "B"

STANDARD DRAWING
2021 EDITION
S - a - 202
SHEET 1 OF 3

TABLE OF DIMENSIONS AND REINFORCING BARS

PIPE DIA	DEPTH TO INV	DIMENSIONS						REINFORCING BARS								
		A	B	C	D	E	△ (MAX)	"r"	"s"	"t"	"u"	"v"	"w"			
48"	UP TO 30'	8"	6"	12"	6"	4'-0"	15°	3 - #6	#6@6	#5@12	#4@6	#4@6	#4@6			
	31' TO 50'			15"		4'-0"	15°	3 - #7	#7@6	#6@12	#4@6	#5@6	#5@6			
51" TO 60"	UP TO 30'	8"	6"	15"	6"	4'-0"	10°	3 - #7	#7@6	#5@12	#4@6	#5@6	#5@6			
	31' TO 50'			18"		4'-4"	15°	3 - #8	#8@6	#6@12	#5@6	#5@6	#6@6			
63" TO 72"	UP TO 30'	10"	7"	15"	7"	4'-0"	10°	4 - #7	#7@6	#5@12	#4@6	#6@6	#5@6			
	31' TO 50'			18"		4'-8"	15°	4 - #8	#8@6	#6@12	#5@6	#7@6	#7@6			
75" TO 84"	UP TO 30'	10"	7"	16"	7"	4'-0"	8°	4 - #7	#7@6	#5@12	#5@6	#6@6	#6@6			
	31' TO 50'			18"		4'-10"	15°	5 - #7	#8@6	#6@12	#5@6	#6@6	#7@6			
90" TO 96"	UP TO 30'	12"	8"	18"	8"	4'-0"	7°	4 - #8	#8@6	#5@12	#5@6	#7@6	#7@6			
	31' TO 50'			20"		5'-2"	15°	5 - #8	#8@6	#6@12	#6@6	#8@6	#8@6			
						4'-0"	7°	4 - #9	#9@6	#6@12	#6@6	#7@6	#7@6			
						5'-2"	15°	5 - #9	#9@6	#6@12	#6@6	#8@6	#8@6			
						4'-0"	7°	4 - #9	#9@6	#6@12	#6@6	#7@6	#7@6			
						5'-2"	15°	5 - #9	#9@6	#6@12	#6@6	#8@6	#8@6			

COUNTY SANITATION DISTRICTS OF LOS ANGELES COUNTY
OFFICE OF CHIEF ENGINEER

ROBERT FERRANTE
CHIEF ENGINEER

STANDARD MANHOLE, TYPE "B"

STANDARD DRAWING
2021 EDITION
S - a - 202
SHEET 2 OF 3

NOTES:

1. ALL MANHOLES SHALL BE PROVIDED WITH A STANDARD PULL RING IN ACCORDANCE WITH S-a-220. THE PULL RING SHALL BE LOCATED 6" ABOVE THE SOFFIT ON THE UPSTREAM SIDE OF THE MANHOLE AND ALONG THE AXIS OF THE DOWNSTREAM OUTLET. WHERE THE MANHOLE IS TO BE USED AS A DOWNSTREAM SIPHON MANHOLE, IT SHALL BE PROVIDED WITH AN ADDITIONAL STANDARD PULL RING, BUT LOCATED 6" ABOVE THE SOFFIT ON THE DOWNSTREAM SIDE OF THE MANHOLE AND ON THE CENTERLINE OF THE UPSTREAM SIPHON PIPE.
2. MANHOLE STEPS SHALL BE IN ACCORDANCE WITH S-a-209 AND SHALL BE UNIFORMLY SPACED NOT MORE THAN 16" APART. THE TOP STEP SHALL BE PLACED WITHIN 16" BELOW THE MANHOLE FRAME. THE BOTTOM MANHOLE STEP SHALL BE PLACED WITHIN 16" ABOVE THE TOP OF THE PIPE. THE MANHOLE STEPS SHALL PROJECT 5". THE MANHOLE STEPS SHALL BE PLACED SUCH THAT THEY ARE ADJACENT TO BUT NOT INTERFERING WITH ACCESS TO THE PULL RING.
3. THE MANHOLE SHALL BE PROVIDED WITH PLASTIC LINER WITH LOCKING EXTENSIONS. THE PLASTIC LINER AND THE PLASTIC LINER INSTALLATION SHALL BE IN ACCORDANCE WITH THE STANDARD SPECIFICATIONS. THE LINER SHALL EXTEND FROM THE BOTTOM OF THE ADJUSTING RINGS TO A POINT IN THE CHANNEL MATCHING THE BOTTOM OF THE LINER IN THE LINED PIPE. LINER RETURNS SHALL BE PROVIDED WHERE THE LINER TERMINATES AT THE ADJUSTING RING. THE JOINT BETWEEN THE LINER AND THE STAINLESS STEEL STEPS AND PULL RINGS SHALL BE THOROUGHLY SEALED WITH MASTIC SEAM MATERIAL AS MANUFACTURED BY LINABOND INC., CAMARILLO, CALIFORNIA (805) 484-7373, OR EQUAL, AFTER APPLICATION OF CLA-2 ACTIVATOR ON PLASTIC LINER AND EP30-HS PRIMER ON STEEL SURFACES. APPLICATION OF SEALANT AND PREPARATION OF SURFACES SHALL BE IN STRICT CONFORMANCE WITH THE MANUFACTURER'S DIRECTIONS.
4. UNLESS OTHERWISE SPECIFIED, ALL CONCRETE SHALL BE 660-C-4000 AND ALL REINFORCING BARS SHALL BE DEFORMED BARS CONFORMING TO ASTM-A706 GRADE 60.
5. A 12" WIDE BY 12" HIGH CONCRETE RING SHALL BE PROVIDED AROUND THE MANHOLE FRAME. IN UNPAVED AREAS, THE CONCRETE RING SHALL BE PROVIDED WITH #3 REBAR, 30 DIAMETER LAP. WIDTH OF RING SHALL BE 12" AS MEASURED FROM CENTER OF LIFTING EYE; HEIGHT SHALL BE AS MEASURED FROM 1.5" BELOW FINAL GRADE IN PAVED AREAS AND AT GRADE IN UNPAVED AREAS.
6. EXCEPT AS NOTED HEREON, THE PRECAST UNITS SHALL BE MANUFACTURED AND TESTED IN ACCORDANCE WITH ASTM C478. THE CURING OF THE PRECAST UNITS SHALL CONFORM TO SECTION 207-2.7 OF THE STANDARD SPECIFICATIONS. AS AN ALTERNATE, THE UNITS MAY BE CURED USING SATURATED STEAM FOR A MINIMUM OF 12 HOURS FOLLOWED BY 6 DAYS OF WATER CURING OR MEMBRANE CURING. IF THE UNITS ARE CURED BY THE ALTERNATE METHOD, THEY SHALL NOT BE SHIPPED PRIOR TO 8 DAYS AFTER CASTING NOR UNTIL THE CONCRETE HAS ATTAINED A MINIMUM STRENGTH OF 4,000 PSI. THE RISER SECTIONS MAY BE REINFORCED OR UNREINFORCED. REINFORCED SECTIONS SHALL HAVE A MINIMUM WALL THICKNESS OF 5" AND UNREINFORCED SECTIONS SHALL HAVE A MINIMUM WALL THICKNESS OF 6". JOINTS SHALL BE TONGUE AND GROOVE AND SHALL BE ASSEMBLED USING CLASS "B" MORTAR. THE MORTARED JOINTS SHALL BE FLUSH AND TROWELED SMOOTH.
7. IN UNIMPROVED AREAS, MANHOLE COVER SHALL BE SET 6" ABOVE SURROUNDING GRADE.

COUNTY SANITATION DISTRICTS OF LOS ANGELES COUNTY
OFFICE OF CHIEF ENGINEER

ROBERT FERRANTE
CHIEF ENGINEER

STANDARD MANHOLE, TYPE "B"

STANDARD DRAWING
2021 EDITION
S - a - 2 0 2
SHEET 3 OF 3

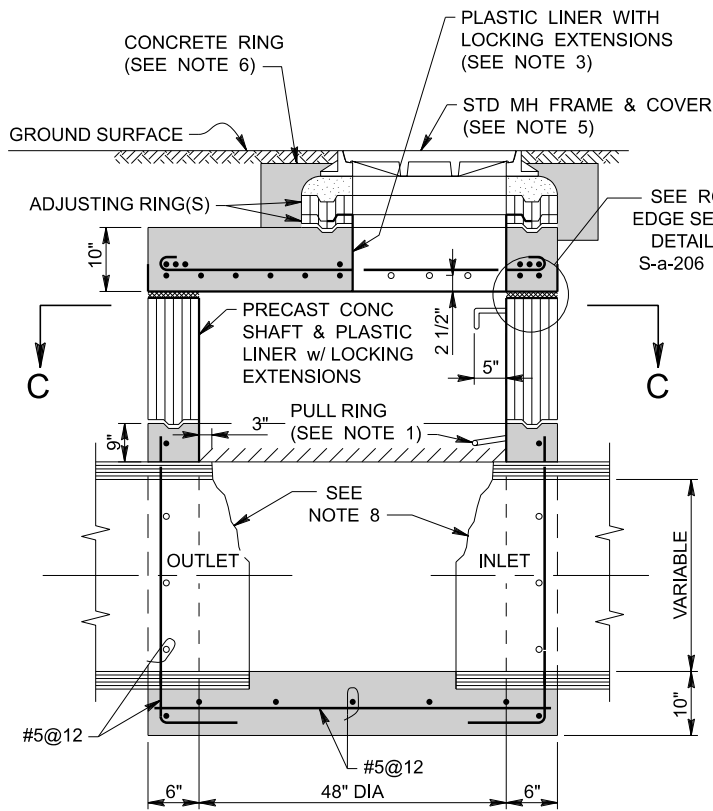

SECTION A-A

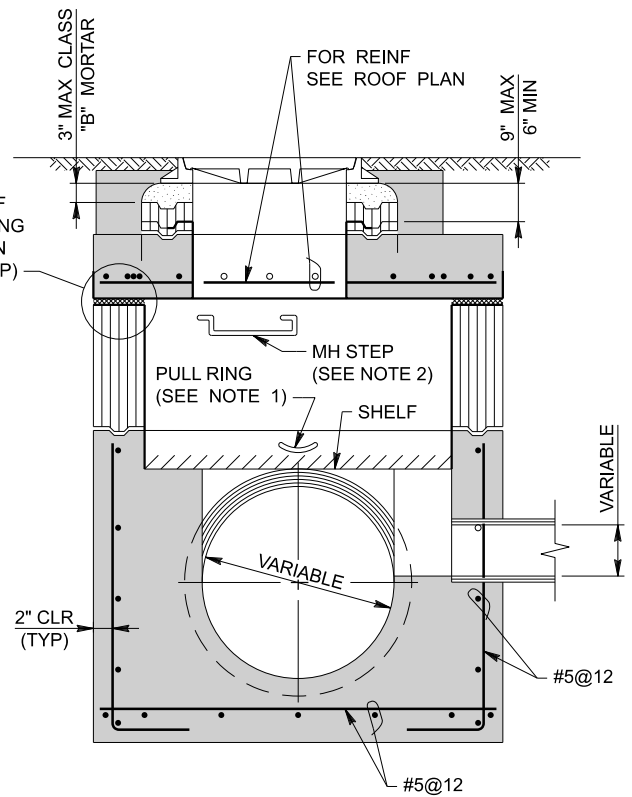

SECTION B-B

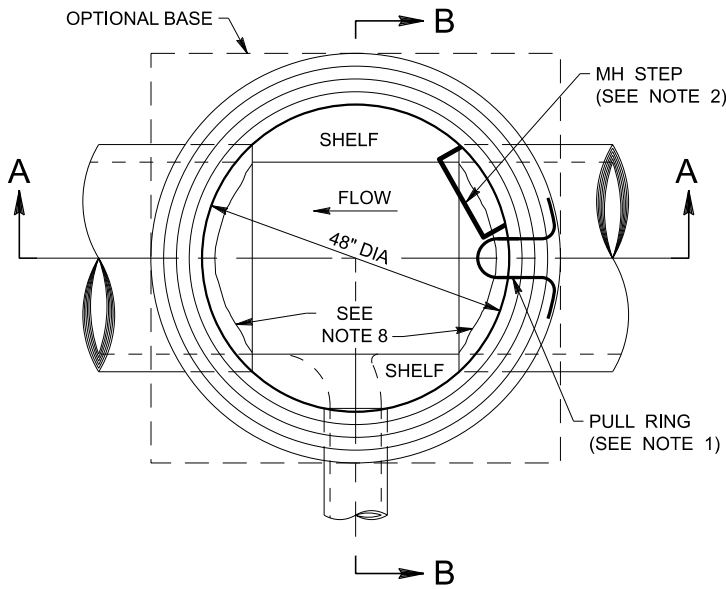

PLAN SECTION C-C

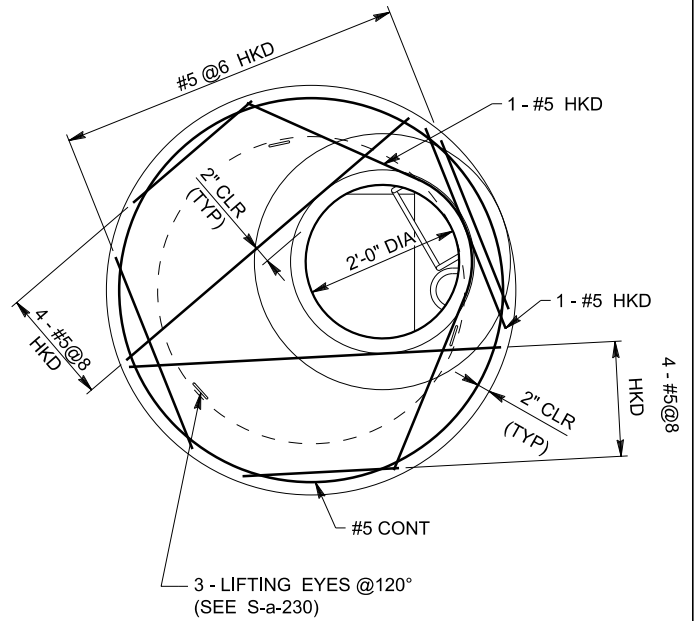

ROOF PLAN

FOR 8" TO 30" PIPE
(< 6' COVER OVER PIPE)

COUNTY SANITATION DISTRICTS OF LOS ANGELES COUNTY
OFFICE OF CHIEF ENGINEER

ROBERT FERRANTE
CHIEF ENGINEER

STANDARD MANHOLE, TYPE "C"

STANDARD DRAWING
2021 EDITION
S - a - 203
SHEET 1 OF 3

NOTES:

1. ALL MANHOLES SHALL BE PROVIDED WITH A STANDARD PULL RING IN ACCORDANCE WITH S-a-220. THE PULL RING SHALL BE LOCATED 6" ABOVE THE SOFFIT ON THE UPSTREAM SIDE OF THE MANHOLE AND ALONG THE AXIS OF THE DOWNSTREAM OUTLET. WHERE THE MANHOLE IS TO BE USED AS A DOWNSTREAM SIPHON MANHOLE, IT SHALL BE PROVIDED WITH AN ADDITIONAL STANDARD PULL RING, BUT LOCATED 6" ABOVE THE SOFFIT ON THE DOWNSTREAM SIDE OF THE MANHOLE AND ON THE CENTERLINE OF THE UPSTREAM SIPHON PIPE.
2. MANHOLE STEPS SHALL BE IN ACCORDANCE WITH S-a-209 AND SHALL BE UNIFORMLY SPACED NOT MORE THAN 16" APART. THE TOP STEP SHALL BE PLACED WITHIN 16" BELOW THE MANHOLE FRAME. THE BOTTOM MANHOLE STEP SHALL BE PLACED WITHIN 16" ABOVE THE TOP OF THE PIPE. THE MANHOLE STEPS SHALL PROJECT 5". THE MANHOLE STEPS SHALL BE PLACED SUCH THAT THEY ARE ADJACENT TO BUT NOT INTERFERING WITH ACCESS TO THE PULL RING.
3. THE MANHOLE SHALL BE PROVIDED WITH PLASTIC LINER WITH LOCKING EXTENSIONS. THE PLASTIC LINER AND THE PLASTIC LINER INSTALLATION SHALL BE IN ACCORDANCE WITH THE STANDARD SPECIFICATIONS. THE LINER SHALL EXTEND FROM THE BOTTOM OF THE ADJUSTING RINGS TO THE TOP OF THE SHELF. LINER RETURNS SHALL BE PROVIDED WHERE THE LINER TERMINATES AT THE ADJUSTING RING. THE JOINT BETWEEN THE LINER AND THE STAINLESS STEEL STEPS AND PULL RINGS SHALL BE THOROUGHLY SEALED WITH MASTIC SEAM MATERIAL AS MANUFACTURED BY LINABOND INC., CAMARILLO, CALIFORNIA (805) 484-7373, OR EQUAL, AFTER APPLICATION OF CLA-2 ACTIVATOR ON PLASTIC LINER AND EP30-HS PRIMER ON STEEL SURFACES. APPLICATION OF SEALANT AND PREPARATION OF SURFACES SHALL BE IN STRICT CONFORMANCE WITH THE MANUFACTURER'S DIRECTIONS.
4. UNLESS OTHERWISE SPECIFIED, ALL CONCRETE SHALL BE 660-C-4000 ALL REINFORCING BARS SHALL BE DEFORMED BARS CONFORMING TO ASTM-A706 GRADE 60.
5. IN PAVED AREAS SUBJECT TO TRAFFIC, A 24" TRAFFIC MANHOLE FRAME AND COVER IN ACCORDANCE WITH S-a-228 SHALL BE PROVIDED. IN ALL OTHER AREAS, A 24" LOCKING MANHOLE FRAME AND COVER IN ACCORDANCE WITH S-a-207 SHALL BE PROVIDED. IF A 30" MANHOLE FRAME AND COVER IS REQUIRED, A FRAME AND COVER IN ACCORDANCE WITH S-a-223 SHALL BE PROVIDED. IN UNIMPROVED AREAS, MANHOLE COVER SHALL BE SET 6" ABOVE SURROUNDING GRADE.
6. A 12" WIDE BY 12" HIGH CONCRETE RING SHALL BE PROVIDED AROUND THE MANHOLE FRAME. IN UNPAVED AREAS, THE CONCRETE RING SHALL BE PROVIDED WITH #3 REBAR, 30 DIAMETER LAP. WIDTH OF RING SHALL BE 12" AS MEASURED FROM CENTER OF LIFTING EYE; HEIGHT SHALL BE AS MEASURED FROM 1.5" BELOW FINAL GRADE IN PAVED AREAS AND AT GRADE IN UNPAVED AREAS.

COUNTY SANITATION DISTRICTS OF LOS ANGELES COUNTY
OFFICE OF CHIEF ENGINEER

ROBERT FERRANTE
CHIEF ENGINEER

STANDARD MANHOLE, TYPE "C"

STANDARD DRAWING
2021 EDITION
S - a - 2 0 3
SHEET 2 OF 3

NOTES CONT.:

7. EXCEPT AS NOTED HEREON, THE PRECAST UNITS SHALL BE MANUFACTURED AND TESTED IN ACCORDANCE WITH ASTM C478. THE CURING OF THE PRECAST UNITS SHALL CONFORM TO SECTION 207-2.7 OF THE STANDARD SPECIFICATIONS. AS AN ALTERNATE, THE UNITS MAY BE CURED USING SATURATED STEAM FOR A MINIMUM OF 12 HOURS FOLLOWED BY 6 DAYS OF WATER CURING OR MEMBRANE CURING. IF THE UNITS ARE CURED BY THE ALTERNATE METHOD, THEY SHALL NOT BE SHIPPED PRIOR TO 8 DAYS AFTER CASTING NOR UNTIL THE CONCRETE HAS ATTAINED A MINIMUM STRENGTH OF 4,000 PSI. THE RISER SECTIONS MAY BE REINFORCED OR UNREINFORCED. REINFORCED SECTIONS, INCLUDING ECCENTRIC CONES, SHALL HAVE A MINIMUM WALL THICKNESS OF 5" AND UNREINFORCED SECTIONS, INCLUDING CONES, SHALL HAVE A MINIMUM WALL THICKNESS OF 6". JOINTS SHALL BE TONGUE AND GROOVE AND SHALL BE ASSEMBLED USING CLASS "B" MORTAR. THE MORTARED JOINTS SHALL BE FLUSH AND TROWELED SMOOTH.

8. THE TOP PORTION OF THE PIPES WITHIN THE MANHOLE SHALL BE CUT OUT AS NECESSARY TO PROVIDE A CIRCULAR OPENING BETWEEN THE PIPE ENDS OF AT LEAST 42". THE CUT ENDS SHALL BE PLASTERED SMOOTH WITH CEMENT MORTAR FOR CONCRETE PIPE AND EPOXY FOR CLAY PIPE. THE CIRCULAR OPENING SHALL BE CUT PRIOR TO INSTALLATION OF THE RISER SECTIONS.

COUNTY SANITATION DISTRICTS OF LOS ANGELES COUNTY
OFFICE OF CHIEF ENGINEER

ROBERT FERRANTE
CHIEF ENGINEER

STANDARD MANHOLE, TYPE "C"

STANDARD DRAWING
2021 EDITION
S - a - 203
SHEET 3 OF 3

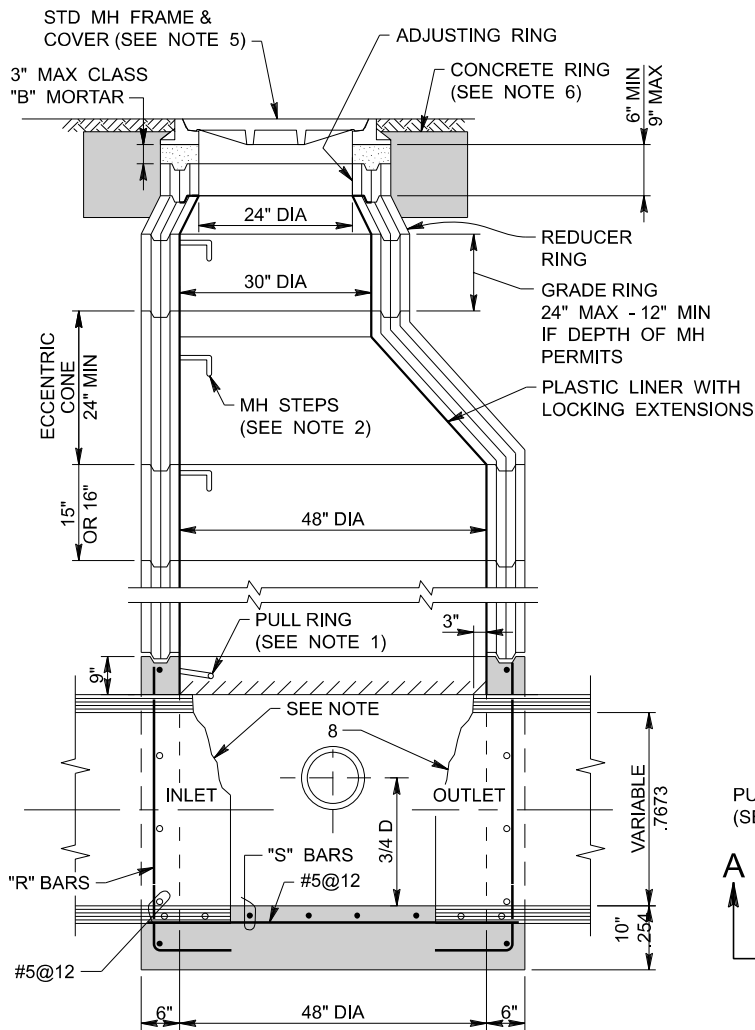

SECTION A-A

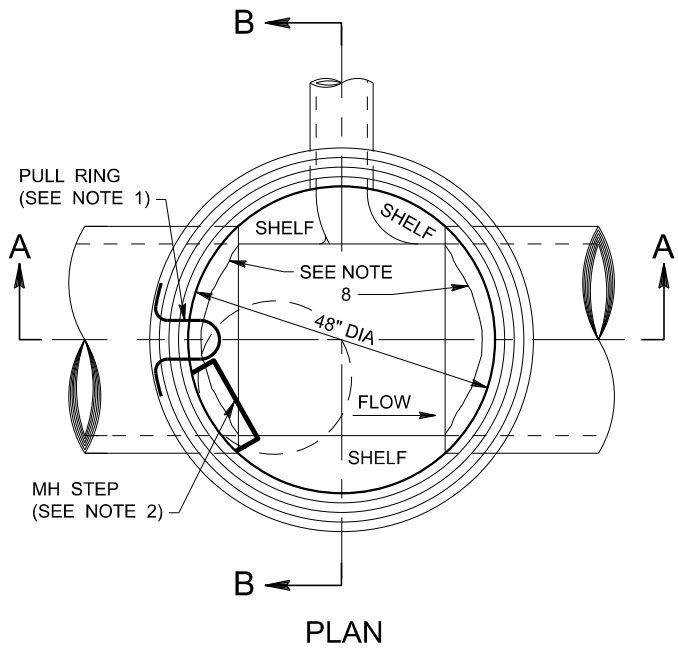

PLAN

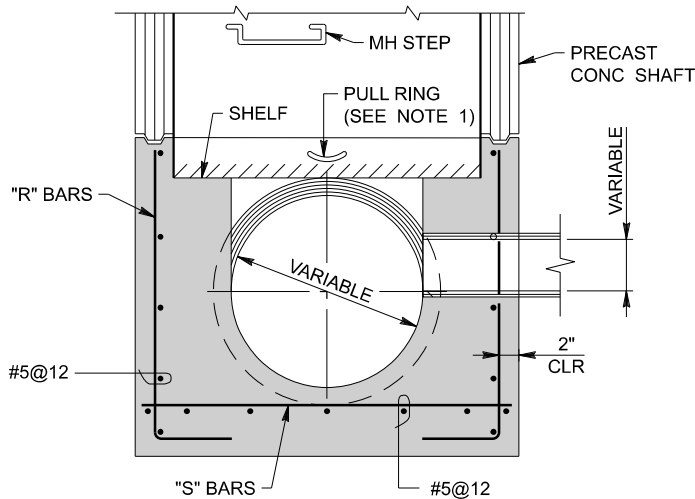

SECTION B-B

TABLE OF REINFORCING BARS			
PIPE DIA	DEPTH TO INV	"R"	"S"
8" TO 21"	UP TO 15'	#5@12	#5@12
	16' TO 30'	#6@12	#6@12
24" TO 30"	UP TO 15'	#5@12	#5@12
	16' TO 30'	#7@12	#6@12

**FOR 8" TO 30" PIPE
(≥ 6" COVER OVER PIPE)**

COUNTY SANITATION DISTRICTS OF LOS ANGELES COUNTY
OFFICE OF CHIEF ENGINEER

ROBERT FERRANTE
CHIEF ENGINEER

STANDARD MANHOLE, TYPE "D"

STANDARD DRAWING
2021 EDITION
S - a - 204
SHEET 1 OF 3

NOTES:

1. ALL MANHOLES SHALL BE PROVIDED WITH A STANDARD PULL RING IN ACCORDANCE WITH S-a-220. THE PULL RING SHALL BE LOCATED 5" ABOVE THE TOP OF PIPE ON THE UPSTREAM SIDE OF THE MANHOLE AND ALONG THE AXIS OF THE DOWNSTREAM OUTLET. WHERE THE MANHOLE IS TO BE USED AS A DOWNSTREAM SIPHON MANHOLE, IT SHALL BE PROVIDED WITH AN ADDITIONAL STANDARD PULL RING, BUT LOCATED 5" ABOVE THE TOP OF PIPE ON THE DOWNSTREAM SIDE OF THE MANHOLE AND ON THE CENTERLINE OF THE UPSTREAM SIPHON PIPE.
2. MANHOLE STEPS SHALL BE IN ACCORDANCE WITH S-a-209 AND SHALL BE UNIFORMLY SPACED NOT MORE THAN 16" APART. THE TOP STEP SHALL BE PLACED WITHIN 16" BELOW THE MANHOLE FRAME. THE BOTTOM MANHOLE STEP SHALL BE PLACED WITHIN 16" ABOVE THE SHELF. IN MANHOLE SHAFTS 36" IN DIAMETER AND LARGER, THE MANHOLE STEPS SHALL PROJECT 5". IN MANHOLE SHAFTS SMALLER THAN 36" IN DIAMETER, THE MANHOLE STEPS SHALL PROJECT 4". THE MANHOLE STEPS SHALL BE PLACED SUCH THAT THEY ARE ADJACENT TO BUT NOT INTERFERING WITH ACCESS TO THE PULL RING.
3. THE MANHOLE SHALL BE PROVIDED WITH PLASTIC LINER WITH LOCKING EXTENSIONS. THE PLASTIC LINER AND ITS INSTALLATION SHALL BE IN ACCORDANCE WITH THE STANDARD SPECIFICATIONS. THE LINER SHALL EXTEND FROM THE BOTTOM OF THE ADJUSTING RINGS TO THE TOP OF THE SHELF. LINER RETURNS SHALL BE PROVIDED WHERE THE LINER TERMINATES AT THE ADJUSTING RING AND THE SHELF. THE JOINT BETWEEN THE LINER AND THE STAINLESS STEEL STEPS AND PULL RING SHALL BE THOROUGHLY SEALED WITH MASTIC SEAM MATERIAL AS MANUFACTURED BY LINABOND INC., CAMARILLO, CALIFORNIA (805) 484-7373, OR EQUAL, AFTER APPLICATION OF CLA-2 ACTIVATOR ON PLASTIC LINER AND EP30-HS PRIMER ON STEEL SURFACES. APPLICATION OF SEALANT AND PREPARATION OF SURFACES SHALL BE IN STRICT CONFORMANCE WITH THE MANUFACTURER'S DIRECTIONS.
4. UNLESS OTHERWISE SPECIFIED, ALL CONCRETE SHALL BE 660-C-4000 ALL REINFORCING BARS SHALL BE DEFORMED BARS CONFORMING TO ASTM-A706 GRADE 60.
5. IN PAVED AREAS SUBJECT TO TRAFFIC, A 24" TRAFFIC MANHOLE FRAME AND COVER IN ACCORDANCE WITH S-a-228 SHALL BE PROVIDED. IN ALL OTHER AREAS, A 24" LOCKING MANHOLE FRAME AND COVER IN ACCORDANCE WITH S-a-207 SHALL BE PROVIDED. IF A 30" MANHOLE FRAME AND COVER IS REQUIRED, A FRAME AND COVER IN ACCORDANCE WITH S-a-223 SHALL BE PROVIDED. IN UNIMPROVED AREAS, MANHOLE COVER SHALL BE SET 6" ABOVE SURROUNDING GRADE.
6. A 12" WIDE BY 12" HIGH CONCRETE RING SHALL BE PROVIDED AROUND THE MANHOLE FRAME. IN UNPAVED AREAS, THE CONCRETE RING SHALL BE PROVIDED WITH #3 REBAR, 30 DIAMETER LAP. WIDTH OF RING SHALL BE 12" AS MEASURED FROM CENTER OF LIFTING EYE; HEIGHT SHALL BE AS MEASURED FROM 1.5" BELOW FINAL GRADE IN PAVED AREAS AND AT GRADE IN UNPAVED AREAS.

COUNTY SANITATION DISTRICTS OF LOS ANGELES COUNTY
OFFICE OF CHIEF ENGINEER

ROBERT FERRANTE
CHIEF ENGINEER

STANDARD MANHOLE, TYPE "D"

STANDARD DRAWING
2021 EDITION
S - a - 204
SHEET 2 OF 3

NOTES CONT.:

7. EXCEPT AS NOTED HEREON, THE PRECAST UNITS SHALL BE MANUFACTURED AND TESTED IN ACCORDANCE WITH ASTM C478. THE CURING OF THE PRECAST UNITS SHALL CONFORM TO SECTION 207-2.7 OF THE STANDARD SPECIFICATIONS. AS AN ALTERNATE, THE UNITS MAY BE CURED USING SATURATED STEAM FOR A MINIMUM OF 12 HOURS FOLLOWED BY 6 DAYS OF WATER CURING OR MEMBRANE CURING. IF THE UNITS ARE CURED BY THE ALTERNATE METHOD, THEY SHALL NOT BE SHIPPED PRIOR TO 8 DAYS AFTER CASTING NOR UNTIL THE CONCRETE HAS ATTAINED A MINIMUM STRENGTH OF 4,000 PSI. THE RISER SECTIONS MAY BE REINFORCED OR UNREINFORCED. REINFORCED SECTIONS, INCLUDING ECCENTRIC CONES, SHALL HAVE A MINIMUM WALL THICKNESS OF 5" AND UNREINFORCED SECTIONS, INCLUDING CONES, SHALL HAVE A MINIMUM WALL THICKNESS OF 6". JOINTS SHALL BE TONGUE AND GROOVE AND SHALL BE ASSEMBLED USING CLASS "B" MORTAR. THE MORTARED JOINTS SHALL BE FLUSH AND TROWELED SMOOTH.

8. THE TOP PORTION OF THE PIPES WITHIN THE MANHOLE SHALL BE CUT OUT AS NECESSARY TO PROVIDE A CIRCULAR OPENING BETWEEN THE PIPE ENDS OF AT LEAST 42". THE CUT ENDS SHALL BE PLASTERED SMOOTH WITH CEMENT MORTAR FOR CONCRETE PIPE AND EPOXY FOR CLAY PIPE. THE CIRCULAR OPENING SHALL BE CUT PRIOR TO INSTALLATION OF THE RISER SECTIONS.

COUNTY SANITATION DISTRICTS OF LOS ANGELES COUNTY
OFFICE OF CHIEF ENGINEER

ROBERT FERRANTE
CHIEF ENGINEER

STANDARD MANHOLE, TYPE "D"

STANDARD DRAWING
2021 EDITION
S - a - 204
SHEET 3 OF 3

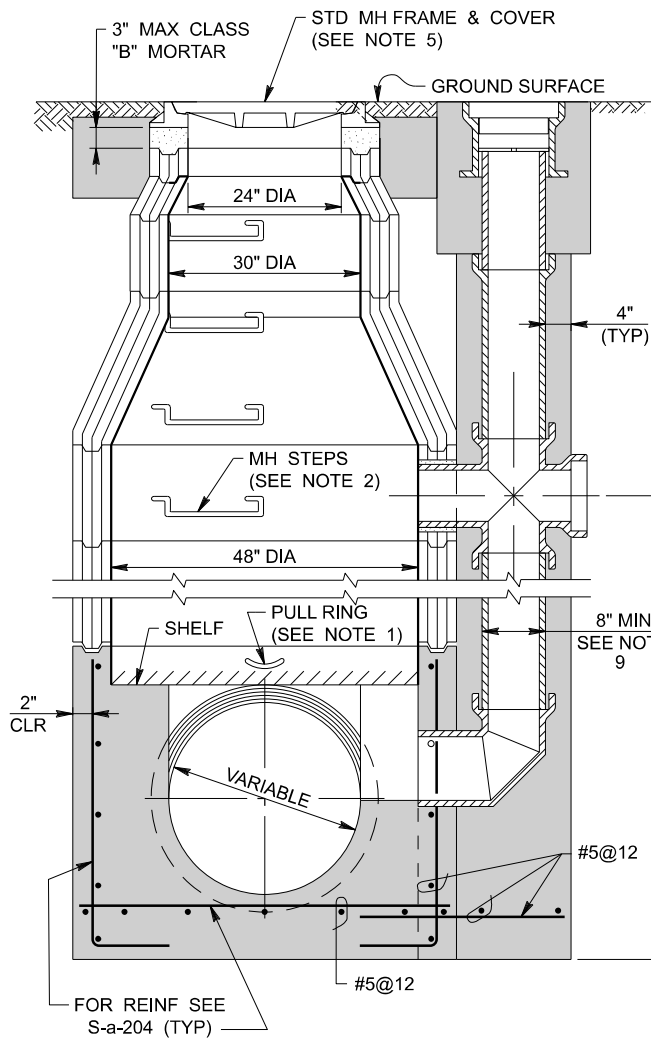

SECTION A-A

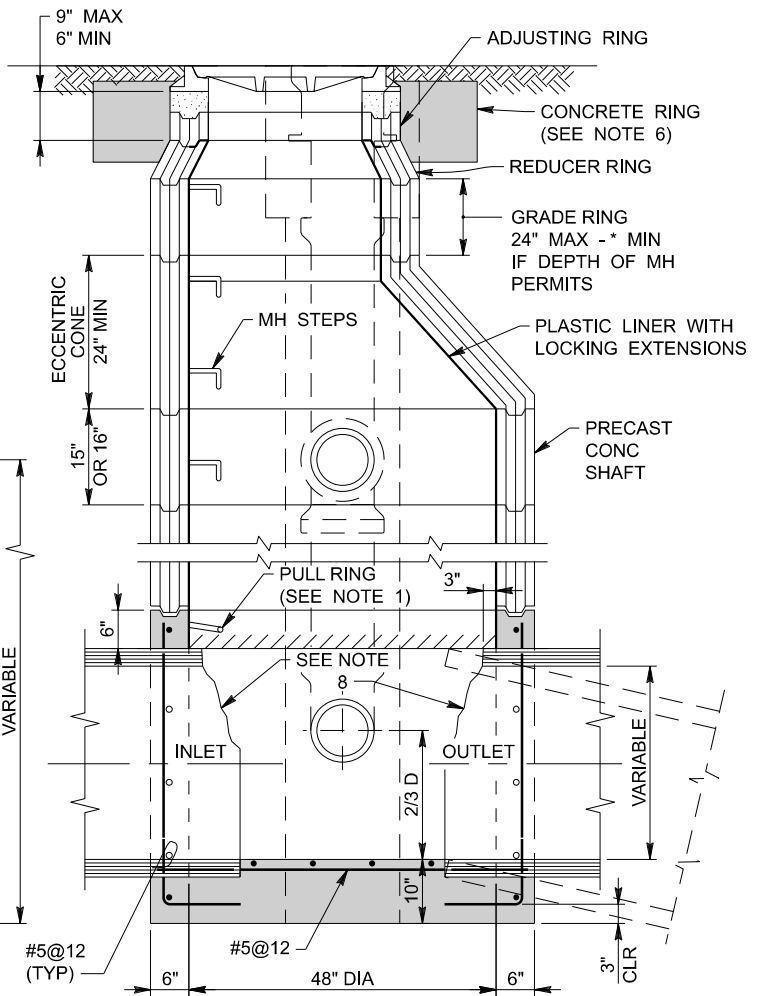

SECTION B-B

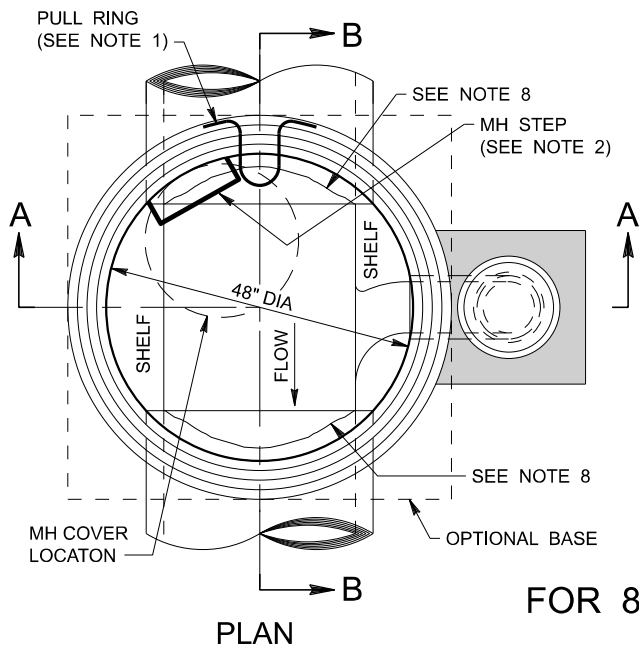

PLAN

FOR 8" TO 30" PIPE

COUNTY SANITATION DISTRICTS OF LOS ANGELES COUNTY
OFFICE OF CHIEF ENGINEER

ROBERT FERRANTE
CHIEF ENGINEER

STANDARD DROP MANHOLE

STANDARD DRAWING
2021 EDITION
S - a - 205
SHEET 1 OF 4

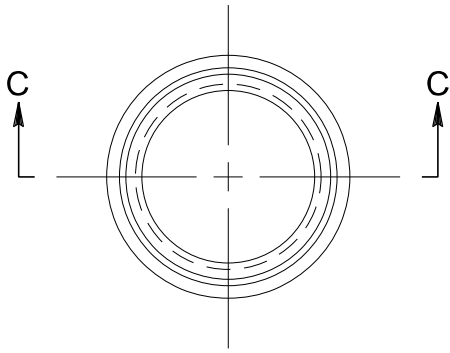

ACCESS FRAME

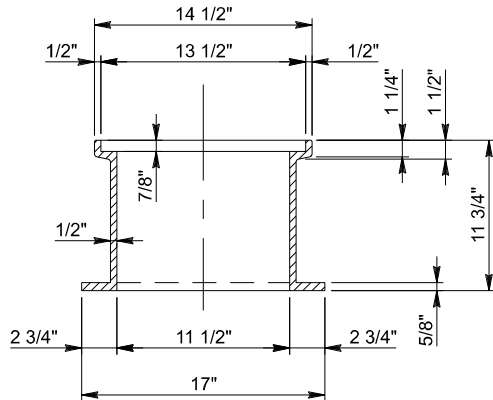

SECTION C-C

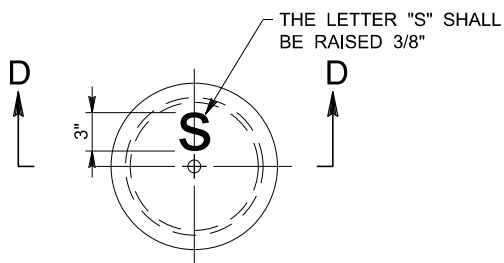

ACCESS COVER

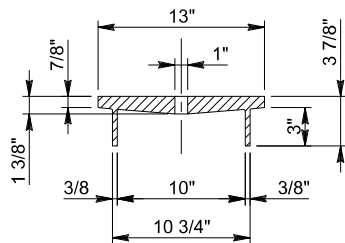

SECTION D-D

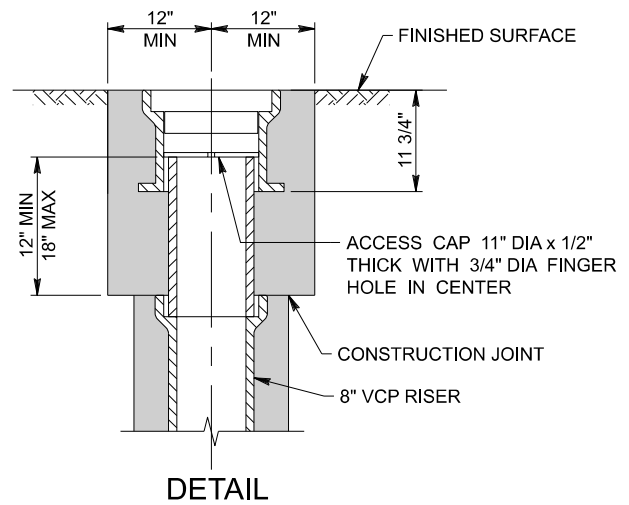

DETAIL

ROBERT FERRANTE
CHIEF ENGINEER

STANDARD DROP MANHOLE

STANDARD DRAWING
2021 EDITION
S - a - 205
SHEET 2 OF 4

NOTES:

1. ALL MANHOLES SHALL BE PROVIDED WITH A STANDARD PULL RING IN ACCORDANCE WITH S-a-220. THE PULL RING SHALL BE LOCATED 5" ABOVE THE TOP OF PIPE ON THE UPSTREAM SIDE OF THE MANHOLE AND ALONG THE AXIS OF THE DOWNSTREAM OUTLET. WHERE THE MANHOLE IS TO BE USED AS A DOWNSTREAM SIPHON MANHOLE, IT SHALL BE PROVIDED WITH AN ADDITIONAL STANDARD PULL RING, BUT LOCATED 5" ABOVE THE TOP OF PIPE ON THE DOWNSTREAM SIDE OF THE MANHOLE AND ON THE CENTERLINE OF THE UPSTREAM SIPHON PIPE.
2. MANHOLE STEPS SHALL BE IN ACCORDANCE WITH S-a-209 AND SHALL BE UNIFORMLY SPACED NOT MORE THAN 16" APART. THE TOP STEP SHALL BE PLACED WITHIN 16" BELOW THE MANHOLE FRAME. THE BOTTOM MANHOLE STEP SHALL BE PLACED WITHIN 16" ABOVE THE SHELF. IN MANHOLE SHAFTS 36" IN DIAMETER AND LARGER, THE MANHOLE STEPS SHALL PROJECT 5". IN MANHOLE SHAFTS SMALLER THAN 36" IN DIAMETER, THE MANHOLE STEPS SHALL PROJECT 4". THE MANHOLE STEPS SHALL BE PLACED SUCH THAT THEY ARE ADJACENT TO BUT NOT INTERFERING WITH ACCESS TO THE PULL RING.
3. THE MANHOLE SHALL BE PROVIDED WITH PLASTIC LINER WITH LOCKING EXTENSIONS. THE PLASTIC LINER AND ITS INSTALLATION SHALL BE IN ACCORDANCE WITH THE STANDARD SPECIFICATIONS. THE LINER SHALL EXTEND FROM THE BOTTOM OF THE ADJUSTING RINGS TO THE TOP OF THE SHELF. LINER RETURNS SHALL BE PROVIDED WHERE THE LINER TERMINATES AT THE ADJUSTING RING AND THE SHELF. THE JOINT BETWEEN THE LINER AND THE STAINLESS STEEL STEPS AND PULL RINGS SHALL BE THOROUGHLY SEALED WITH MASTIC SEAM MATERIAL AS MANUFACTURED BY LINABOND INC., CAMARILLO, CALIFORNIA (805) 484-7373, OR EQUAL, AFTER APPLICATION OF CLA-2 ACTIVATOR ON PLASTIC LINER AND EP30-HS PRIMER ON STEEL SURFACES. APPLICATION OF SEALANT AND PREPARATION OF SURFACES SHALL BE IN STRICT CONFORMANCE WITH THE MANUFACTURER'S DIRECTIONS.
4. UNLESS OTHERWISE SPECIFIED, ALL CONCRETE SHALL BE 660-C-4000 ALL REINFORCING BARS SHALL BE DEFORMED BARS CONFORMING TO ASTM-A706 GRADE 60.
5. IN PAVED AREAS SUBJECT TO TRAFFIC, A 24" TRAFFIC MANHOLE FRAME AND COVER IN ACCORDANCE WITH S-a-228 SHALL BE PROVIDED. IN ALL OTHER AREAS, A 24" LOCKING MANHOLE FRAME AND COVER IN ACCORDANCE WITH S-a-207 SHALL BE PROVIDED. IF A 30" MANHOLE FRAME AND COVER IS REQUIRED, A FRAME AND COVER IN ACCORDANCE WITH S-a-223 SHALL BE PROVIDED. IN UNIMPROVED AREAS, MANHOLE COVER SHALL BE SET 6" ABOVE SURROUNDING GRADE.
6. A 12" WIDE BY 12" HIGH CONCRETE RING SHALL BE PROVIDED AROUND THE MANHOLE FRAME. IN UNPAVED AREAS, THE CONCRETE RING SHALL BE PROVIDED WITH #3 REBAR, 30 DIAMETER LAP. WIDTH OF RING SHALL BE 12" AS MEASURED FROM CENTER OF LIFTING EYE; HEIGHT SHALL BE AS MEASURED FROM 1.5" BELOW FINAL GRADE IN PAVED AREAS AND AT GRADE IN UNPAVED AREAS.

COUNTY SANITATION DISTRICTS OF LOS ANGELES COUNTY
OFFICE OF CHIEF ENGINEER

ROBERT FERRANTE
CHIEF ENGINEER

STANDARD DROP MANHOLE

STANDARD DRAWING
2021 EDITION
S - a - 205
SHEET 3 OF 4

NOTES CONT.:

7. EXCEPT AS NOTED HEREON, THE PRECAST UNITS SHALL BE MANUFACTURED AND TESTED IN ACCORDANCE WITH ASTM C478 THE CURING OF THE PRECAST UNITS SHALL CONFORM TO SECTION 207-2.7 OF THE STANDARD SPECIFICATIONS. AS AN ALTERNATE, THE UNITS MAY BE CURED USING SATURATED STEAM FOR A MINIMUM OF 12 HOURS FOLLOWED BY 6 DAYS OF WATER CURING OR MEMBRANE CURING. IF THE UNITS ARE CURED BY THE ALTERNATE METHOD, THEY SHALL NOT BE SHIPPED PRIOR TO 8 DAYS AFTER CASTING NOR UNTIL THE CONCRETE HAS ATTAINED A MINIMUM STRENGTH OF 4,000 PSI. THE RISER SECTIONS MAY BE REINFORCED OR UNREINFORCED. REINFORCED SECTIONS, INCLUDING ECCENTRIC CONES, SHALL HAVE A MINIMUM WALL THICKNESS OF 5" AND UNREINFORCED SECTIONS, INCLUDING CONES, SHALL HAVE A MINIMUM WALL THICKNESS OF 6". JOINTS SHALL BE TONGUE AND GROOVE AND SHALL BE ASSEMBLED USING CLASS "B" MORTAR. THE MORTARED JOINTS SHALL BE FLUSH AND TROWELED SMOOTH.
8. THE TOP PORTION OF THE PIPES WITHIN THE MANHOLE SHALL BE CUT OUT AS NECESSARY TO PROVIDE A CIRCULAR OPENING BETWEEN THE PIPE ENDS OF AT LEAST 42". THE CUT ENDS SHALL BE PLASTERED SMOOTH WITH CEMENT MORTAR FOR CONCRETE PIPE AND EPOXY FOR CLAY PIPE. THE CIRCULAR OPENING SHALL BE CUT PRIOR TO INSTALLATION OF THE RISER SECTIONS.
9. THE DROP CONNECTION INTO THE MANHOLE SHALL BE VCP AND SHALL BE THE SAME SIZE AS THE LATERAL SEWER OR A MINIMUM OF 8" IN DIAMETER, WHICHEVER IS LARGER. THE RISER SHALL BE 8" VCP.

COUNTY SANITATION DISTRICTS OF LOS ANGELES COUNTY
OFFICE OF CHIEF ENGINEER

ROBERT FERRANTE
CHIEF ENGINEER

STANDARD DROP MANHOLE

STANDARD DRAWING
2021 EDITION
S - a - 205
SHEET 4 OF 4

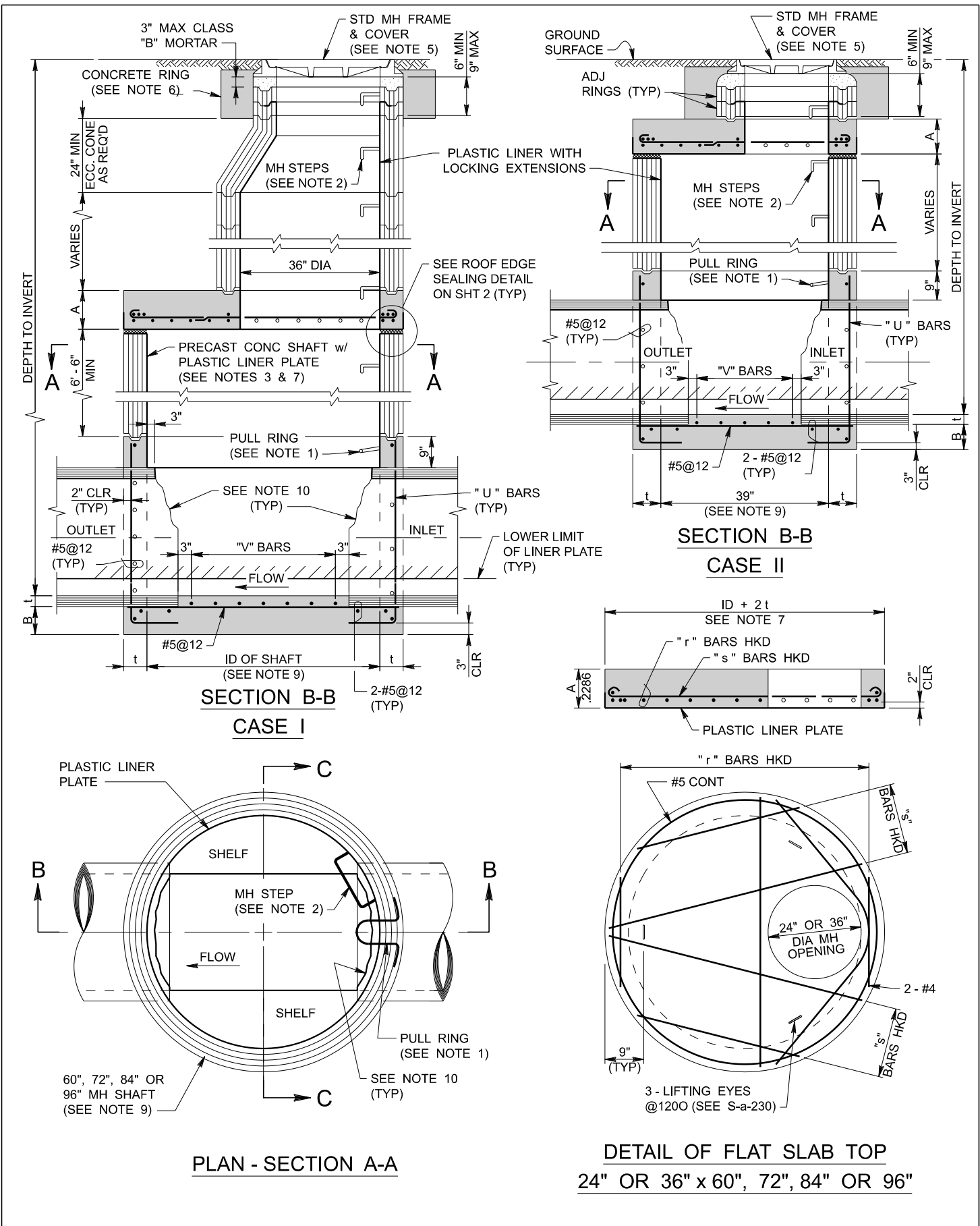

COUNTY SANITATION DISTRICTS OF LOS ANGELES COUNTY
OFFICE OF CHIEF ENGINEER

ROBERT FERRANTE
CHIEF ENGINEER

STANDARD MANHOLE, TYPE "E"

STANDARD DRAWING
2021 EDITION
S - a - 206
SHEET 1 OF 4

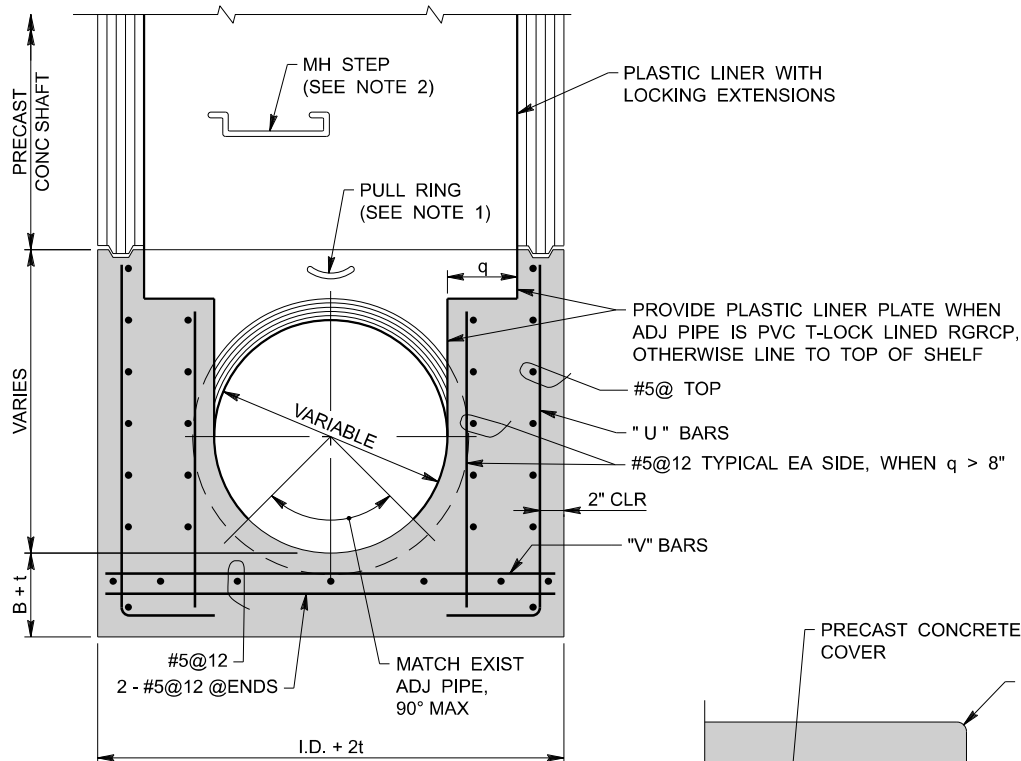

SECTION C-C

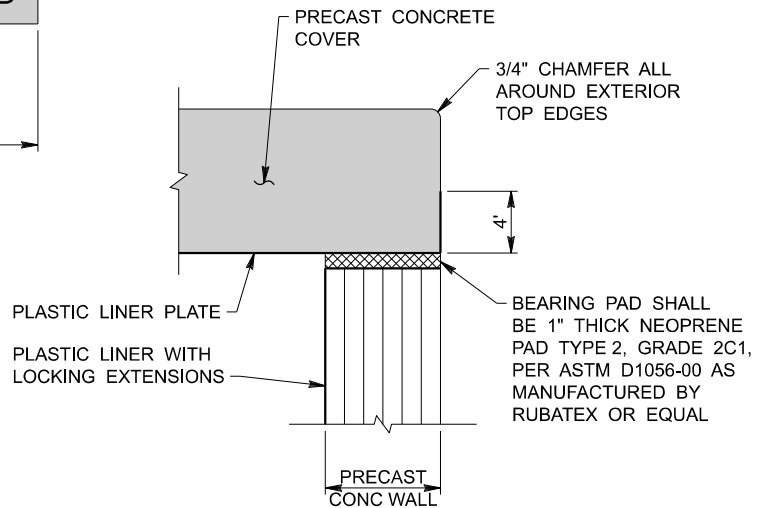

ROOF EDGE SEALING DETAIL

TABLE OF REINFORCING BARS

SHAFT DIA	DEPTH TO INV	DIMENSIONS		REINFORCING BARS			
		A	B	" r "	" s "	" u "	" v "
60"	UP TO 15'	10"	8"	#6@6	#6@6	#5@12	#5@12
	16' TO 30'	12"	10"	#7@6	#7@6	#6@10	#6@12
72"	UP TO 15'	10"	8"	#6@6	#6@6	#5@12	#5@12
	16' TO 30'	12"	10"	#8@6	#8@6	#7@12	#7@12
84"	UP TO 15'	10"	10"	#7@6	#7@6	#5@12	#5@12
	16' TO 30'	14"	10"	#8@6	#8@6	#7@12	#8@12
96"	UP TO 15'	12"	10"	#7@6	#7@6	#6@12	#6@12
	16' TO 30'	15"	12"	#8@6	#8@6	#7@6	#8@12

COUNTY SANITATION DISTRICTS OF LOS ANGELES COUNTY
OFFICE OF CHIEF ENGINEER

ROBERT FERRANTE
CHIEF ENGINEER

STANDARD MANHOLE, TYPE "E"

STANDARD DRAWING
2021 EDITION
S - a - 206
SHEET 2 OF 4

NOTES:

1. ALL MANHOLES SHALL BE PROVIDED WITH A STANDARD PULL RING IN ACCORDANCE WITH S-a-220. THE PULL RING SHALL BE LOCATED 5" ABOVE THE TOP OF PIPE ON THE UPSTREAM SIDE OF THE MANHOLE AND ALONG THE AXIS OF THE DOWNSTREAM OUTLET. WHERE THE MANHOLE IS TO BE USED AS A DOWNSTREAM SIPHON MANHOLE, IT SHALL BE PROVIDED WITH AN ADDITIONAL STANDARD PULL RING, BUT LOCATED 5" ABOVE THE TOP OF PIPE ON THE DOWNSTREAM SIDE OF THE MANHOLE AND ON THE CENTERLINE OF THE UPSTREAM SIPHON PIPE.
2. MANHOLE STEPS SHALL BE IN ACCORDANCE WITH S-a-209 AND SHALL BE UNIFORMLY SPACED NOT MORE THAN 16" APART. THE TOP STEP SHALL BE PLACED WITHIN 16" BELOW THE MANHOLE FRAME. THE BOTTOM MANHOLE STEP SHALL BE PLACED WITHIN 16" ABOVE THE SHELF. IN MANHOLE SHAFTS 36" IN DIAMETER AND LARGER, THE MANHOLE STEPS SHALL PROJECT 5". IN MANHOLE SHAFTS SMALLER THAN 36" IN DIAMETER, THE MANHOLE STEPS SHALL PROJECT 4". THE MANHOLE STEPS SHALL BE PLACED SUCH THAT THEY ARE ADJACENT TO BUT NOT INTERFERING WITH ACCESS TO THE PULL RING.
3. THE MANHOLE SHALL BE PROVIDED WITH PLASTIC LINER WITH LOCKING EXTENSIONS. THE PLASTIC LINER AND ITS INSTALLATION SHALL BE IN ACCORDANCE WITH THE STANDARD SPECIFICATIONS. THE LINER SHALL EXTEND FROM THE BOTTOM OF THE ADJUSTING RINGS TO THE TOP OF THE SHELF UNLESS THE ADJACENT PIPE IS LINED. IF THE ADJACENT PIPE IS LINED, THE LINER SHALL EXTEND TO A POINT IN THE CHANNEL MATCHING THE BOTTOM OF THE LINER IN THE LINED PIPE. LINER RETURNS SHALL BE PROVIDED WHERE THE LINER TERMINATES AT THE ADJUSTING RING AND THE SHELF. THE JOINT BETWEEN THE LINER AND THE STAINLESS STEEL STEPS AND PULL RINGS SHALL BE THOROUGHLY SEALED WITH MASTIC SEAM MATERIAL AS MANUFACTURED BY LINABOND INC., CAMARILLO, CALIFORNIA (805) 484-7373, OR EQUAL, AFTER APPLICATION OF CLA-2 ACTIVATOR ON PLASTIC LINER AND EP30-HS PRIMER ON STEEL SURFACES. APPLICATION OF SEALANT AND PREPARATION OF SURFACES SHALL BE IN STRICT CONFORMANCE WITH THE MANUFACTURER'S DIRECTIONS.
4. UNLESS OTHERWISE SPECIFIED, ALL CONCRETE SHALL BE 660-C-4000 ALL REINFORCING BARS SHALL BE DEFORMED BARS CONFORMING TO ASTM-A706 GRADE 60.
5. IN PAVED AREAS SUBJECT TO TRAFFIC, A 24" TRAFFIC MANHOLE FRAME AND COVER IN ACCORDANCE WITH S-a-228 SHALL BE PROVIDED. IN ALL OTHER AREAS, A 24" LOCKING MANHOLE FRAME AND COVER IN ACCORDANCE WITH S-a-207 SHALL BE PROVIDED. IF A 30" MANHOLE FRAME AND COVER IS REQUIRED, A FRAME AND COVER IN ACCORDANCE WITH S-a-223 SHALL BE PROVIDED. IN UNIMPROVED AREAS, MANHOLE COVER SHALL BE SET 6" ABOVE SURROUNDING GRADE.
6. A 12" WIDE BY 12" HIGH CONCRETE RING SHALL BE PROVIDED AROUND THE MANHOLE FRAME. IN UNPAVED AREAS, THE CONCRETE RING SHALL BE PROVIDED WITH #3 REBAR, 30 DIAMETER LAP. WIDTH OF RING SHALL BE 12" AS MEASURED FROM CENTER OF LIFTING EYE; HEIGHT SHALL BE AS MEASURED FROM 1.5" BELOW FINAL GRADE IN PAVED AREAS AND AT GRADE IN UNPAVED AREAS.

COUNTY SANITATION DISTRICTS OF LOS ANGELES COUNTY
OFFICE OF CHIEF ENGINEER

ROBERT FERRANTE
CHIEF ENGINEER

STANDARD MANHOLE, TYPE "E"

STANDARD DRAWING
2021 EDITION

S - a - 206

SHEET 3 OF 4

NOTES CONT.:

7. EXCEPT AS NOTED HEREON, THE PRECAST UNITS SHALL BE MANUFACTURED AND TESTED IN ACCORDANCE WITH ASTM C478. THE CURING OF THE PRECAST UNITS SHALL CONFORM TO SECTION 207-2.7 OF THE STANDARD SPECIFICATIONS. AS AN ALTERNATE, THE UNITS MAY BE CURED USING SATURATED STEAM FOR A MINIMUM OF 12 HOURS FOLLOWED BY 6 DAYS OF WATER CURING OR MEMBRANE CURING. IF THE UNITS ARE CURED BY THE ALTERNATE METHOD, THEY SHALL NOT BE SHIPPED PRIOR TO 8 DAYS AFTER CASTING NOR UNTIL THE CONCRETE HAS ATTAINED A MINIMUM STRENGTH OF 4,000 PSI. THE RISER SECTIONS MAY BE REINFORCED OR UNREINFORCED. REINFORCED SECTIONS, INCLUDING ECCENTRIC CONES, SHALL HAVE A MINIMUM WALL THICKNESS OF 5" AND UNREINFORCED SECTIONS, INCLUDING CONES, SHALL HAVE A MINIMUM WALL THICKNESS OF 6". JOINTS SHALL BE TONGUE AND GROOVE AND SHALL BE ASSEMBLED USING CLASS "B" MORTAR. THE MORTARED JOINTS SHALL BE FLUSH AND TROWELED SMOOTH.
8. UNLESS OTHERWISE INDICATED ON THE PLANS OR SPECIAL PROVISIONS, CASE I OR II MAY BE USED BY THE CONTRACTOR AT HIS OPTION CONSISTENT WITH THE FOLLOWING DEPTH OF COVER LIMITATIONS:
CASE I SHALL NOT BE USED FOR COVER ON PIPE LESS THAN 12'.
CASE II SHALL NOT BE USED FOR COVER ON PIPE MORE THAN 12'.
9. RISER SECTIONS 60" THROUGH 96" I.D. SHALL BE REINFORCED IN ACCORDANCE WITH ASTM C 478 AND SHALL HAVE THE FOLLOWING MINIMUM WALL THICKNESS:
60" I.D. - 5"; 72" I.D. - 6"; 84" I.D. - 7"; 96" I.D. - 8".
10. THE TOP PORTION OF THE PIPES WITHIN THE MANHOLE SHALL BE CUT OUT AS NECESSARY TO PROVIDE A CIRCULAR OPENING BETWEEN THE PIPE ENDS OF AT LEAST 54" IN THE 60" DIAMETER MANHOLE AND 66" IN THE 72" DIAMETER MANHOLE, 78" IN THE 84" DIAMETER MANHOLE AND 90" IN THE 96" DIAMETER MANHOLE. THE CUT ENDS SHALL BE PLASTERED SMOOTH WITH CEMENT MORTAR FOR CONCRETE PIPE AND EPOXY FOR CLAY PIPE. THE CIRCULAR OPENING SHALL BE CUT PRIOR TO INSTALLATION OF THE RISER SECTIONS.

COUNTY SANITATION DISTRICTS OF LOS ANGELES COUNTY
OFFICE OF CHIEF ENGINEER

ROBERT FERRANTE
CHIEF ENGINEER

STANDARD MANHOLE, TYPE "E"

STANDARD DRAWING
2021 EDITION
S - a - 206
SHEET 4 OF 4

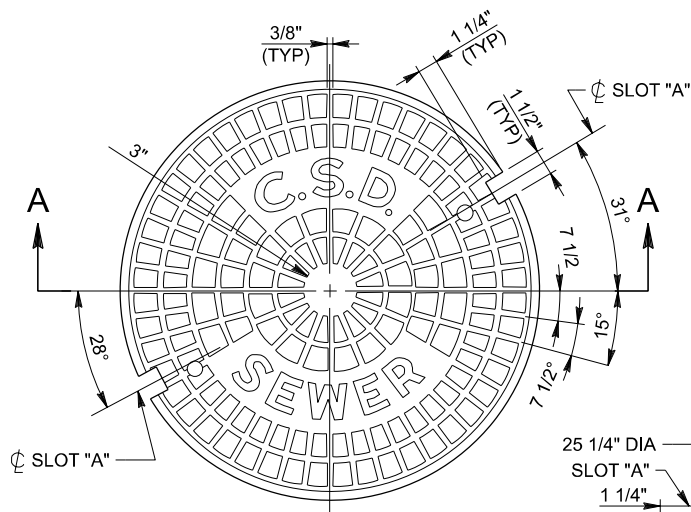

PLAN OF COVER
TOP VIEW

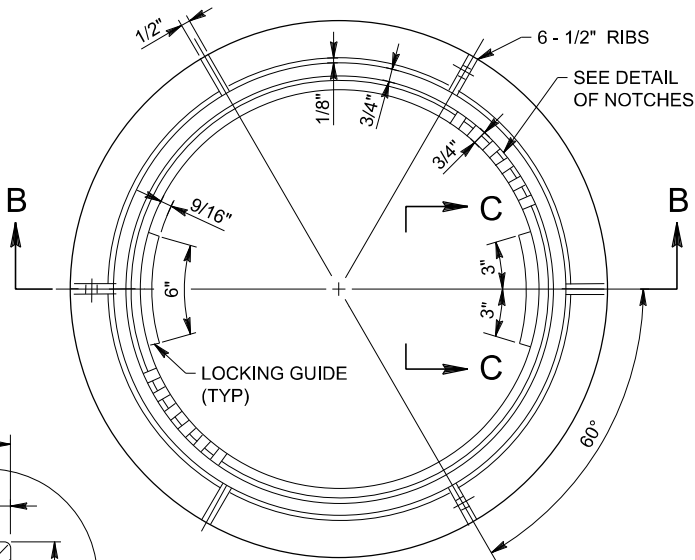

PLAN OF FRAME

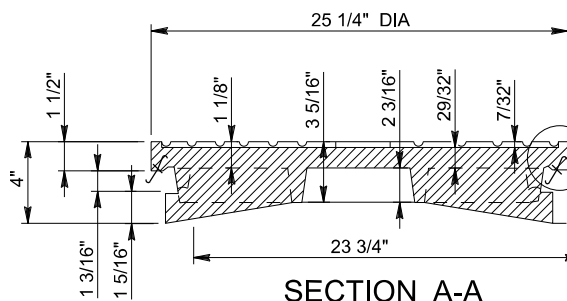
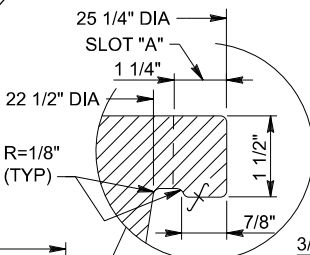

SECTION A-A

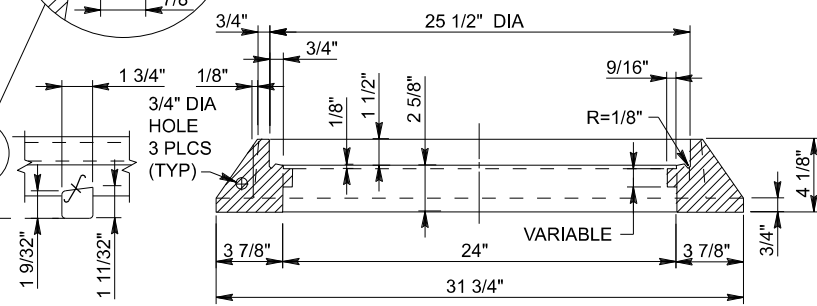

SECTION B-B

**END VIEW
COVER LUG**

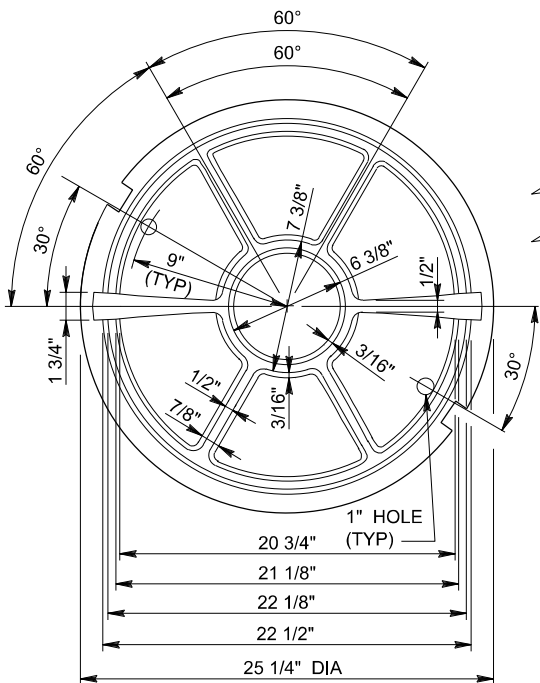

PLAN OF COVER
BOTTOM VIEW

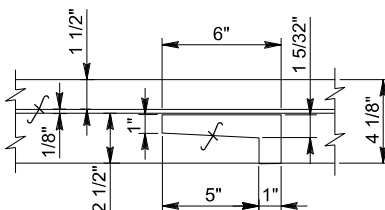

**SIDE VIEW C-C
LOCKING GUIDE**

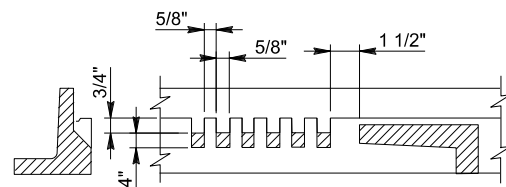

DETAIL OF NOTCHES

NOTES:

1. CAST IRON USED SHALL CONFORM TO ASTM A-48 CLASS 35B.
2. FRAME AND COVER SHALL BE COATED WITH ASPHALTUM OR BITUMINOUS PAINT AFTER TESTING AND INSPECTION.
3. FRAME AND COVER SHALL BE TESTED FOR ACCURATE FIT PRIOR TO DELIVERY AND SHALL BE MARKED IN SETS.
4. ALL CASTINGS SHALL COMPLY WITH SECTION 206-3 OF THE STANDARD SPECIFICATIONS.

COUNTY SANITATION DISTRICTS OF LOS ANGELES COUNTY
OFFICE OF CHIEF ENGINEER

ROBERT FERRANTE
CHIEF ENGINEER

**STANDARD 24" LOCKING MANHOLE
FRAME AND COVER**

STANDARD DRAWING
2021 EDITION
S - a - 207
SHEET 1 OF 1

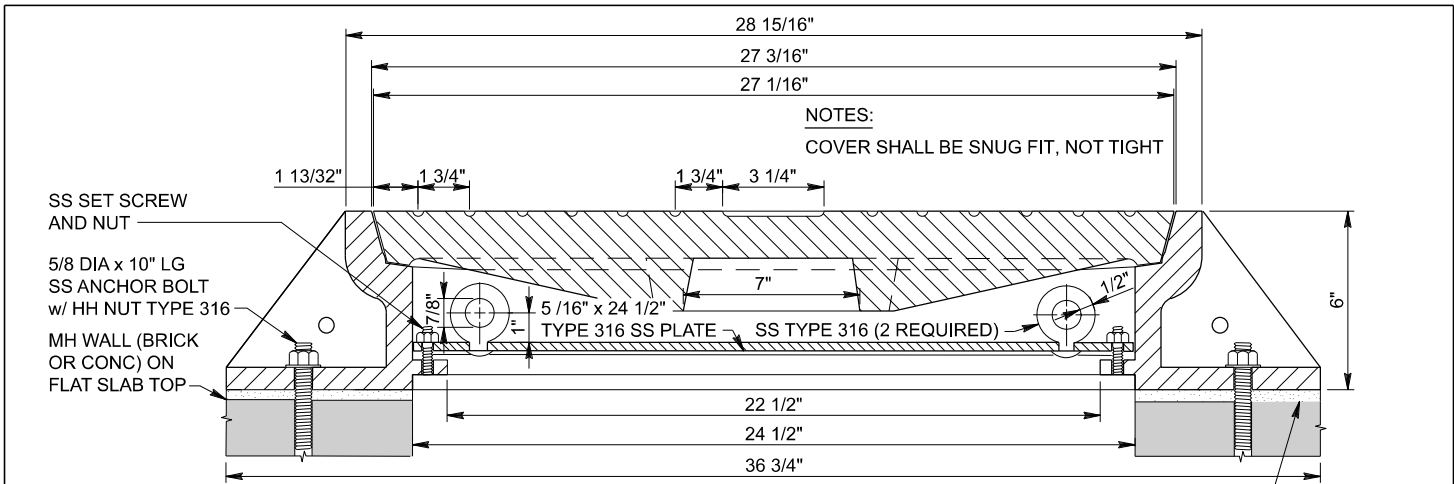

**SECTION
MANHOLE FRAME AND COVER**

CASTING TO BE SET IN WET MORTAR

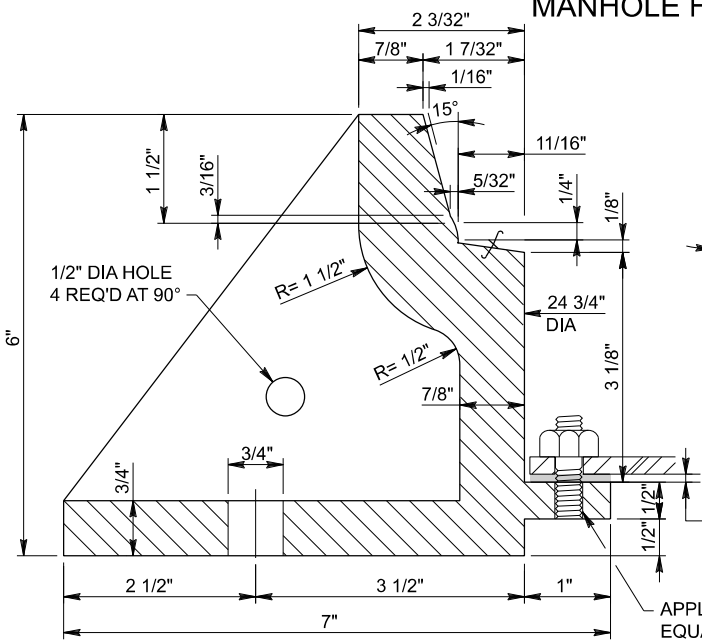

SECTION A-A

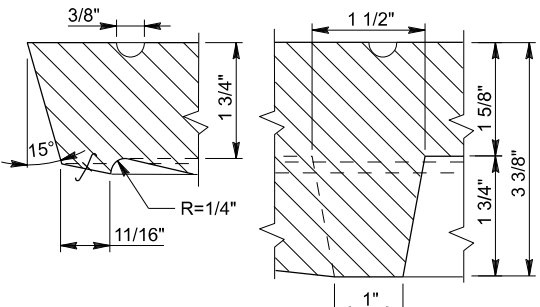

SECTION B-B

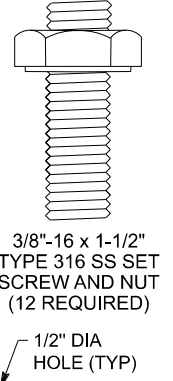

3/8"-16 x 1-1/2" TYPE 316 SS SET SCREW AND NUT (12 REQUIRED)

1/2" DIA HOLE (TYP)

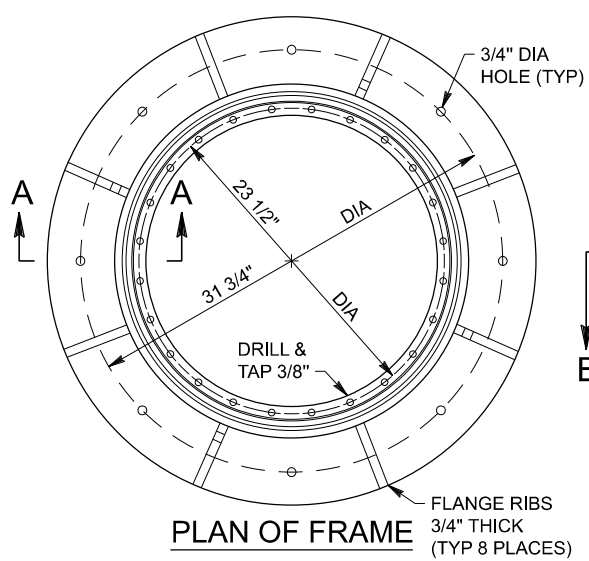

PLAN OF FRAME

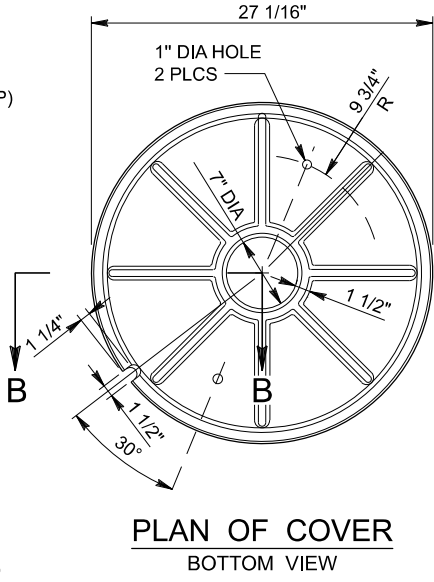

**PLAN OF COVER
BOTTOM VIEW**

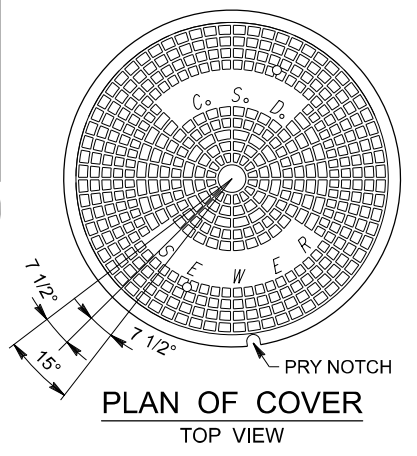

PRESSURE PLATE

**PLAN OF COVER
TOP VIEW**

NOTE:
FOR NOTES, SEE S-a-207.

COUNTY SANITATION DISTRICTS OF LOS ANGELES COUNTY
OFFICE OF CHIEF ENGINEER

ROBERT FERRANTE
CHIEF ENGINEER

**STANDARD 24" PRESSURE MANHOLE
FRAME AND COVER**

STANDARD DRAWING
2021 EDITION
S - a - 208
SHEET 1 OF 1

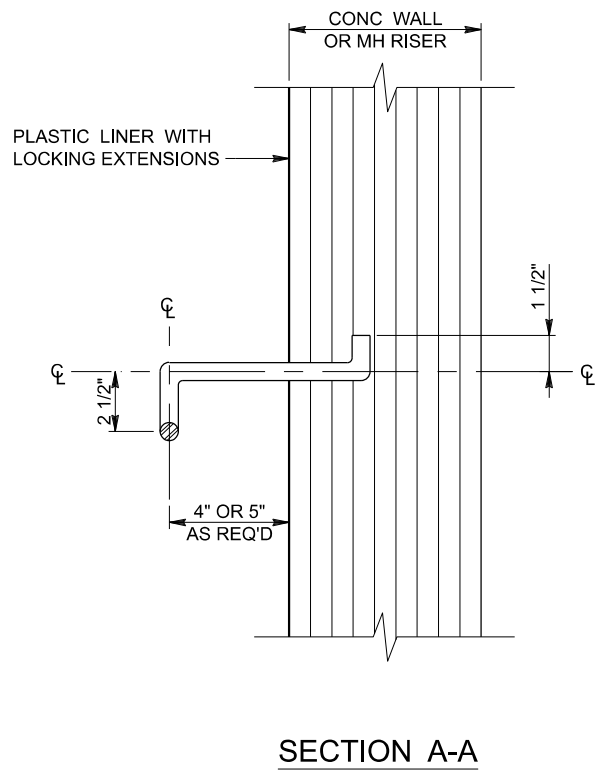
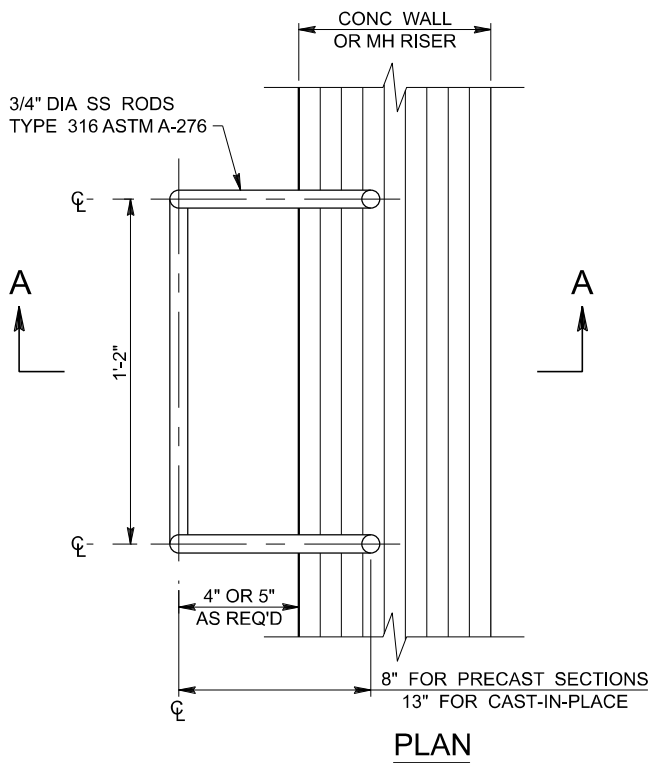

TYPE I MANHOLE STEP

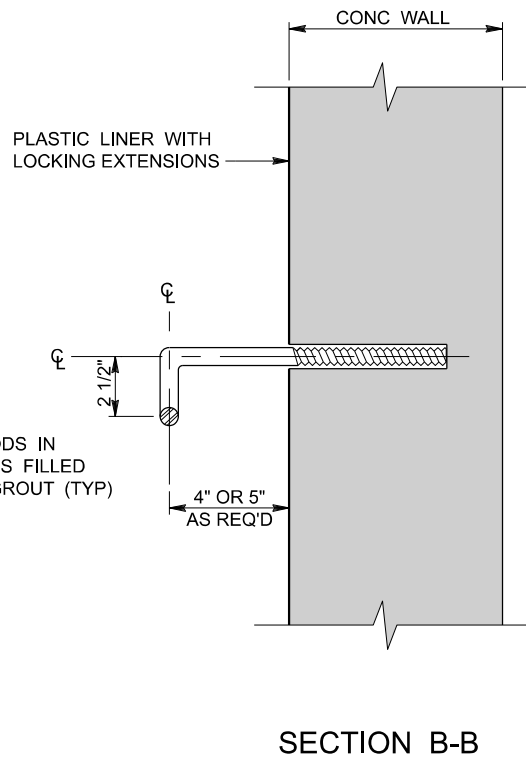
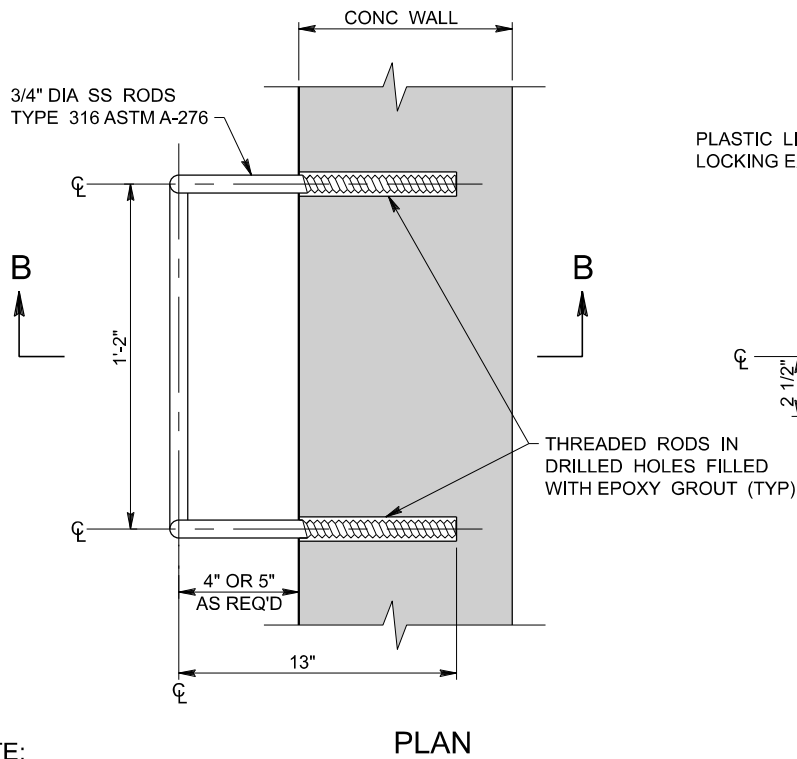

NOTE:
SEE NOTE 3 OF S-a-202
FOR PLASTIC LINER JOINT
SEALING REQUIREMENTS AT
STEP PENETRATIONS

TYPE II MANHOLE STEP

COUNTY SANITATION DISTRICTS OF LOS ANGELES COUNTY
OFFICE OF CHIEF ENGINEER

ROBERT FERRANTE
CHIEF ENGINEER

STANDARD MANHOLE STEP

STANDARD DRAWING
2021 EDITION
S - a - 209
SHEET 1 OF 1

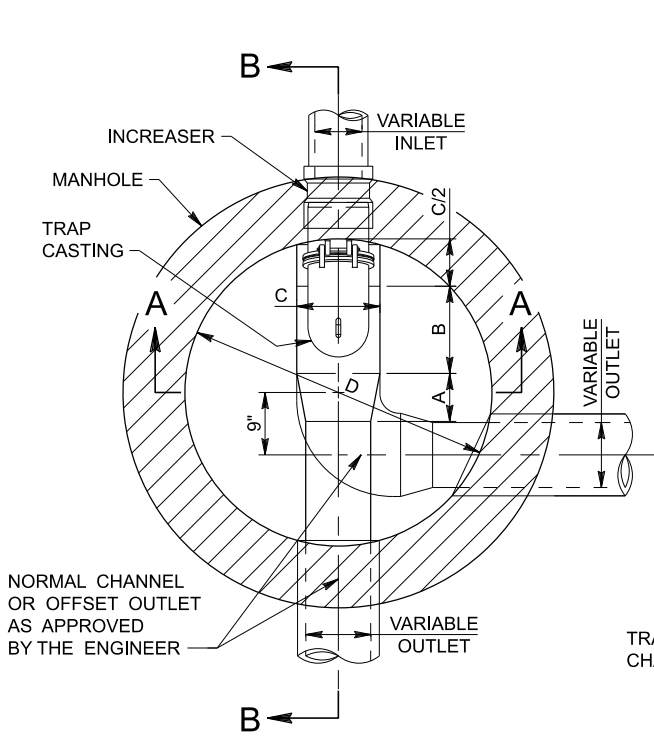

PLAN - SINGLE TRAP BASE

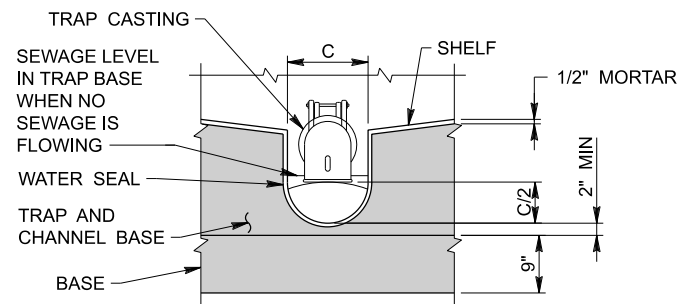

SECTION A-A

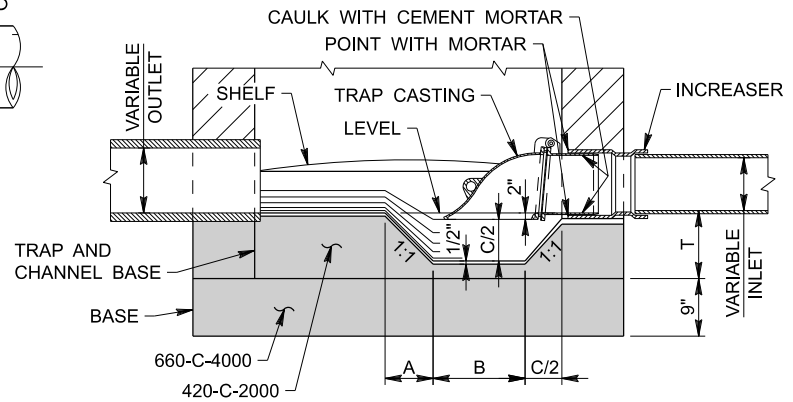

SECTION B-B

TABLE OF DIMENSIONS						
INLET DIA	INLET INCREASER	TRAP SIZE	TRAP PER	DIA OF MANHOLE BASE (D)		
				OUTLET DIAMETER		
				8"	10"	12"
8"	8" x 10"	10"	S-a-211	4'	4'	4'
10"	10" x 12"	12"	S-a-211	—	4'	4'

(FOR 12" INLETS AND LARGER SEE PLANS)

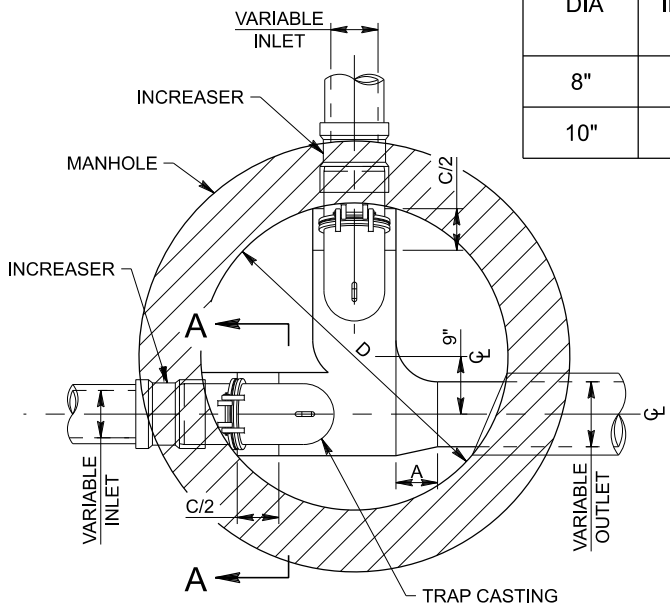

PLAN - DOUBLE TRAP BASE

TRAP BASE DIMENSIONS					
TRAP DIA	A	B	C	A + B + C/2	T MIN
10"	7 1/2"	14 1/2"	13"	28 1/2"	9"
12"	8 1/2"	16 1/2"	15"	32 1/2"	10"

NOTES:

- WHERE A TRAP IS NECESSARY IN AN EXISTING STRUCTURE, BREAK OUT CONCRETE AND CONSTRUCT NEW BASE.
- FOR GENERAL NOTES AND CONSTRUCTION DETAILS OF BRICKWORK, SEE S-a-201.

DIMENSIONS OF CASTINGS				
INLET DIA	A	B	R	L
10"	6"	9"	11"	14 3/4"
12"	7"	11"	13"	17 3/4"

NOTES:

1. CAST IRON USED SHALL CONFORM WITH ASTM A-48 CLASS 35B.
2. FLANGES OF CASTING SHALL BE MACHINED FACED.
3. CASTINGS SHALL BE DIPPED TWICE IN HOT ASPHALT PAINT.
4. RUBBER GASKET SHALL BE NEOPRENE 35-50 SHORE.

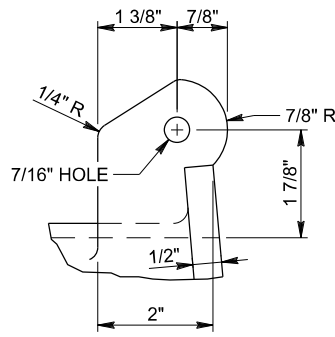

DETAIL "A"

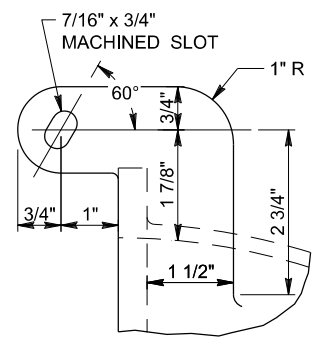

DETAIL "B"

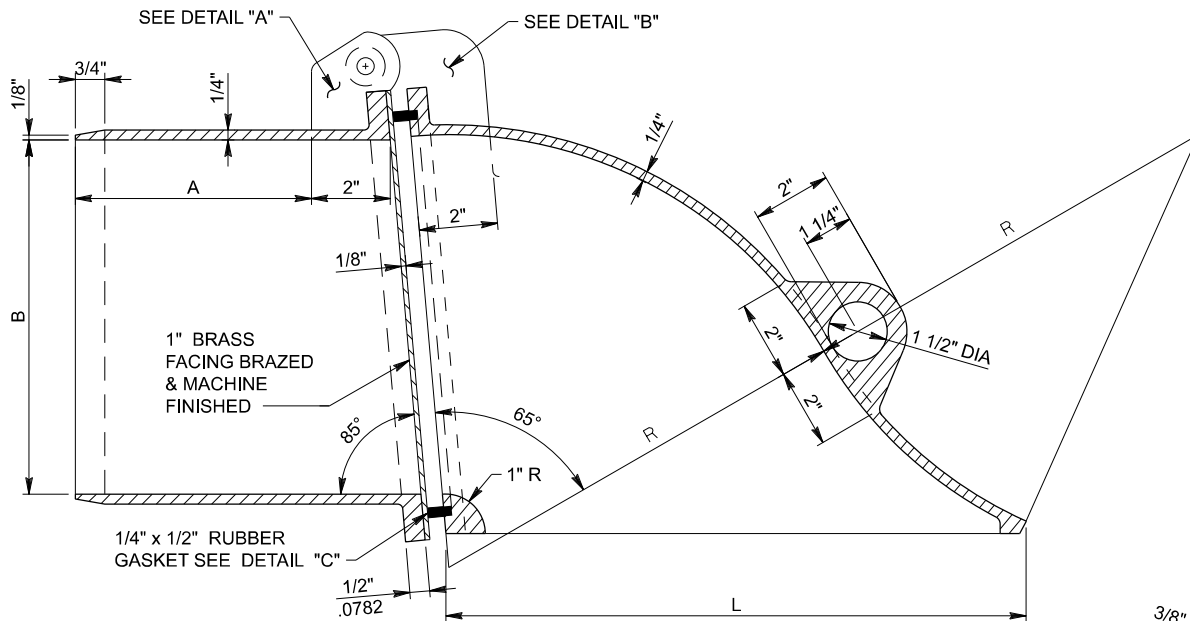

SECTIONAL VIEW

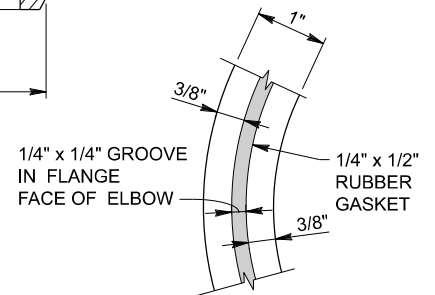

DETAIL "C"

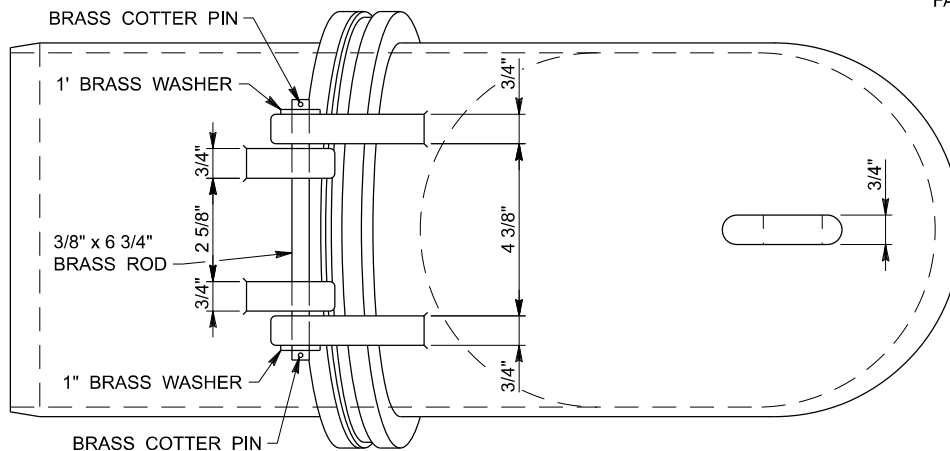

PLAN VIEW

COUNTY SANITATION DISTRICTS OF LOS ANGELES COUNTY
OFFICE OF CHIEF ENGINEER

ROBERT FERRANTE
CHIEF ENGINEER

STANDARD TRAP CASTING

STANDARD DRAWING
2021 EDITION
S - a - 2 1 1
SHEET 1 OF 1

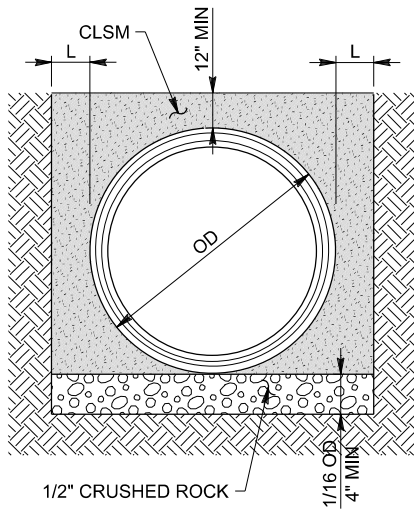

CLSM ENCASEMENT
LOAD FACTOR = 2.8)

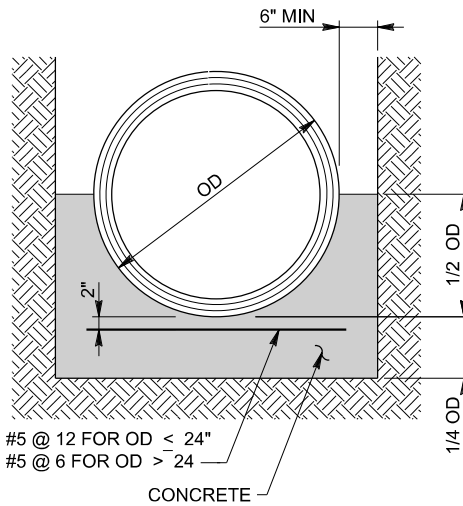

CONCRETE CRADLE
LOAD FACTOR = 3.4)

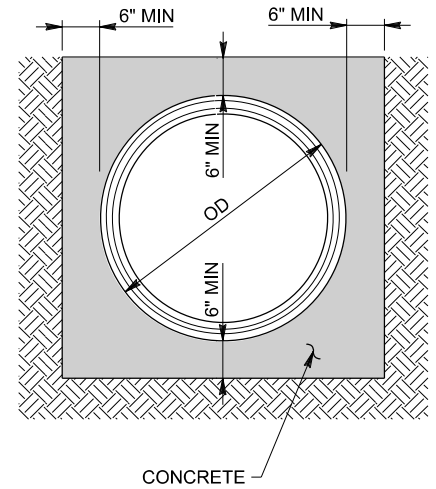

CONCRETE ENCASEMENT
LOAD FACTOR = 4.5)

NOTES:

1. CLSM SHALL BE PER 201-6.1.1. BACKFILL SHALL NOT BE PLACED UNTIL CLSM ACHIEVES A MINIMUM 500 PSI PENETROMETER READING AS DETERMINED BY ASTM C 403.
2. CONCRETE SHALL BE 660-B-4000. BACKFILL SHALL NOT BE PLACED UNTIL AT LEAST 40 HOURS AFTER CONCRETE PLACEMENT. FOR BACKFILL AFTER 16 HOURS, USE 660-C-4000 WITH A NON-CHLORIDE ACCELERATING ADMIXTURE APPROVED BY THE ENGINEER AT DOSAGES AS REQUIRED BY THE MANUFACTURER OF THE ADMIXTURE.
3. REINFORCEMENT STEEL SHALL BE ASTM A615 GRADE 60.
4. CRUSHED ROCK SHALL BE PER 200-1.2.1.
5. L = 9 INCHES MIN FOR PIPE DIAMETERS BETWEEN 8 AND 21 INCHES AND 12 INCHES MIN FOR PIPE DIAMETERS OF 24 INCHES AND GREATER.
6. UNLESS OTHERWISE AUTHORIZED BY THE ENGINEER, ALL CRADLES AND ENCASEMENTS SHALL BE PLACED SUCH THAT BOTH ENDS TERMINATE WITHIN 18 INCHES OF A FLEXIBLE JOINT.
7. FOR REINFORCED CONCRETE PIPE (RCP), SEE SPECIFICATIONS FOR MAXIMUM ALLOWABLE TRENCH WIDTH AND REQUIREMENTS FOR WHEN MAXIMUM TRENCH WIDTH HAS BEEN EXCEEDED.

COUNTY SANITATION DISTRICTS OF LOS ANGELES COUNTY
OFFICE OF CHIEF ENGINEER

ROBERT FERRANTE
CHIEF ENGINEER

**STANDARD CRADLES
AND ENCASEMENTS**

STANDARD DRAWING
2021 EDITION
S - a - 2 1 2
SHEET 1 OF 1

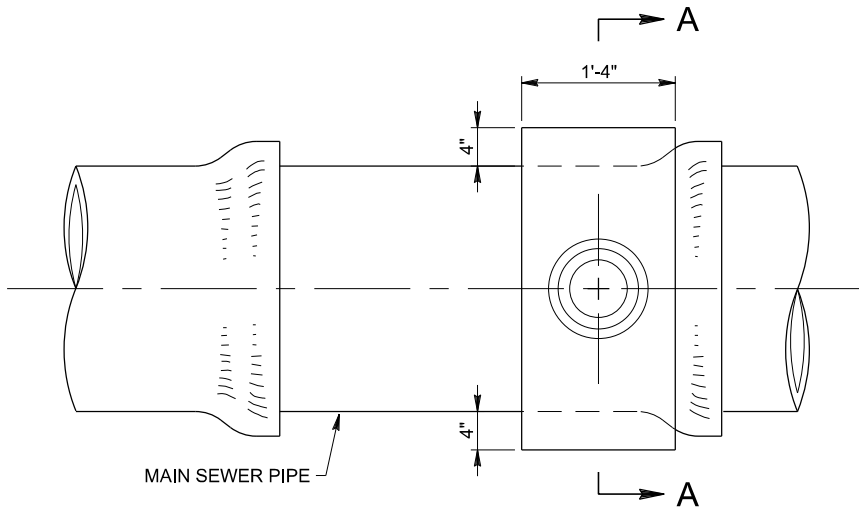

MAIN SEWER PIPE

PLAN

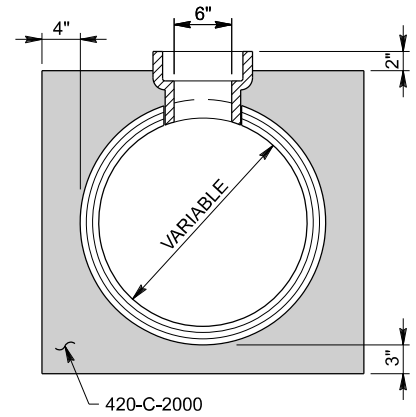

SECTION A-A

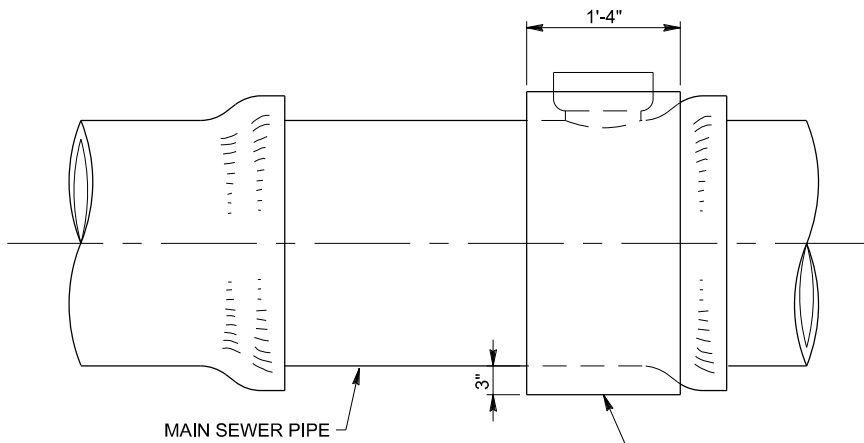

MAIN SEWER PIPE

THIS PORTION MAY BE OMITTED IN
FIRM SOIL WHEN APPROVED BY THE
DISTRICTS' INSPECTOR

ELEVATION

COUNTY SANITATION DISTRICTS OF LOS ANGELES COUNTY
OFFICE OF CHIEF ENGINEER

ROBERT FERRANTE
CHIEF ENGINEER

STANDARD " T " SADDLE

STANDARD DRAWING
2021 EDITION
S - a - 2 1 3
SHEET 1 OF 1

NOTES:

1. THE UPPER END OF THE CHIMNEY PIPE SHALL BE 8 FEET BELOW THE GRADE OF THE LOWER CURB, UNLESS OTHERWISE SPECIFIED.
2. WHERE ONE OR TWO HOUSE CONNECTIONS ARE TO BE JOINED TO THE CHIMNEY PIPE, USE A SINGLE "Y" BRANCH. WHERE THREE HOUSE CONNECTIONS ARE TO BE JOINED USE A DOUBLE "Y" BRANCH.
3. WHERE THE CHIMNEY PIPE IS TO BE USED FOR A SINGLE HOUSE CONNECTION, FACE THE "Y" TOWARDS THE PROPERTY TO BE SERVED; WHERE USED FOR HOUSE CONNECTIONS ON BOTH SIDES OF THE SEWER, THE "Y" SHALL FACE TOWARD THE RIGHT (LOOKING UP GRADE) AND THE HOUSE ON THAT SIDE SHALL BE CONNECTED TO THE "Y" BRANCH BY A 6 INCH ONE-EIGHTH BEND AND THE HOUSE CONNECTION ON THE LEFT SIDE SHALL BE CONNECTED TO THE UPPER END OF THE CHIMNEY BY A 6 INCH ONE-QUARTER BEND UNLESS OTHERWISE SPECIFIED.
4. THE MAIN SEWER PIPE SHALL BE OF THE MATERIAL SHOWN ON THE PLANS.

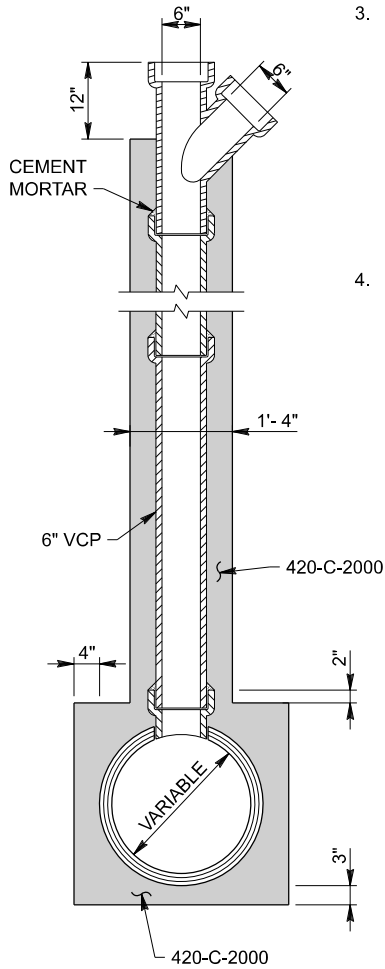

SECTION A-A

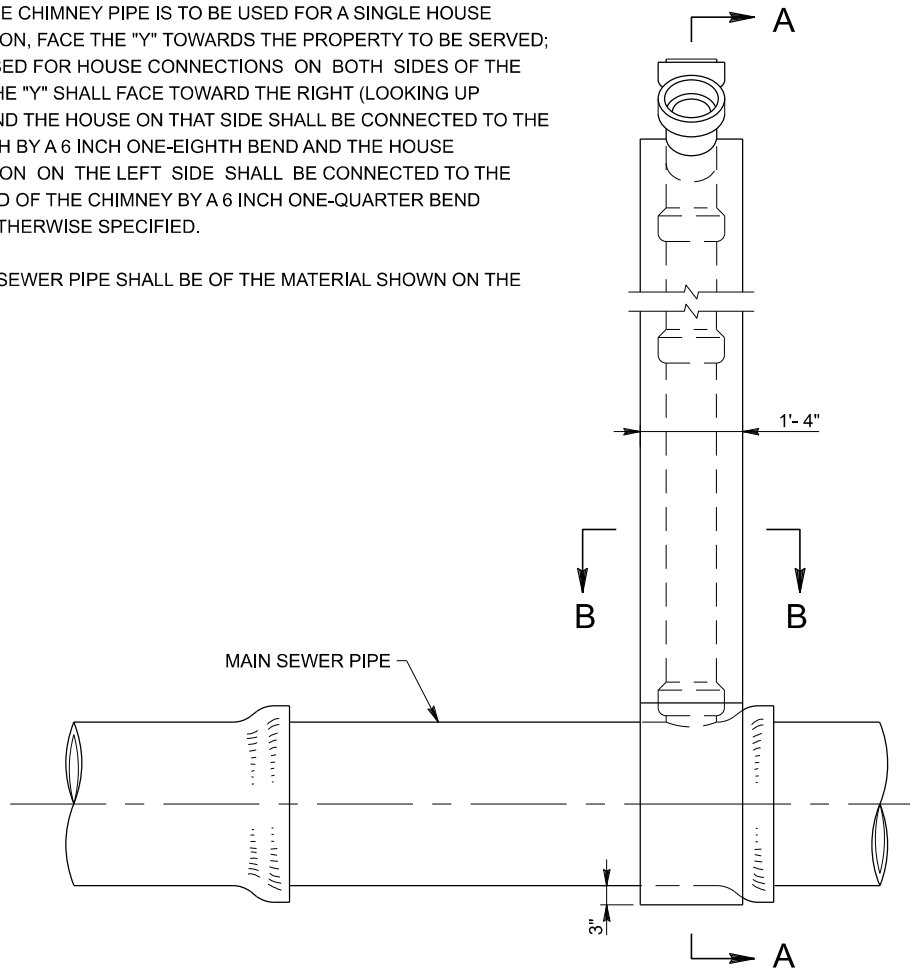

ELEVATION

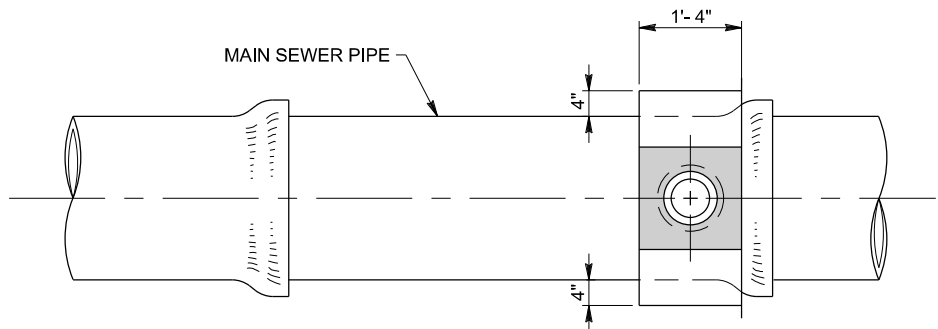

PLAN-SECTION B-B

COUNTY SANITATION DISTRICTS OF LOS ANGELES COUNTY
OFFICE OF CHIEF ENGINEER

ROBERT FERRANTE
CHIEF ENGINEER

STANDARD CHIMNEY PIPE

STANDARD DRAWING
2021 EDITION
S - a - 2 1 4
SHEET 1 OF 1

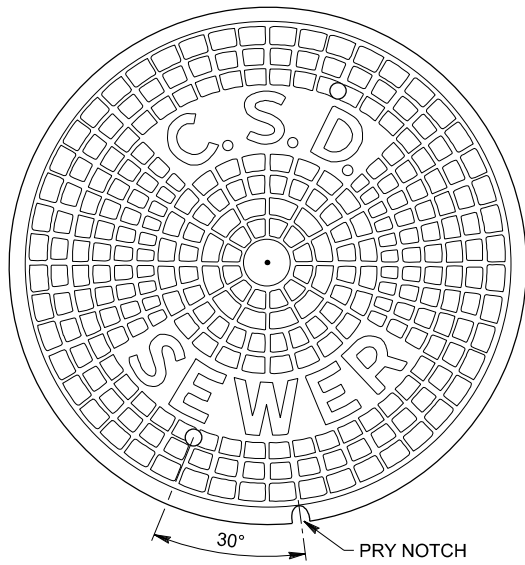

PLAN OF COVER

TOP VIEW

40 1/2"

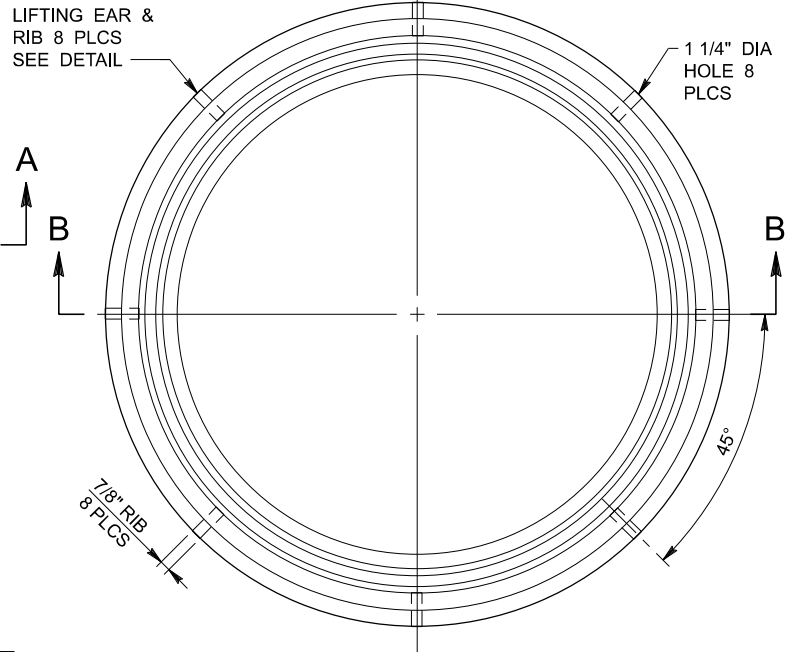

PLAN OF FRAME

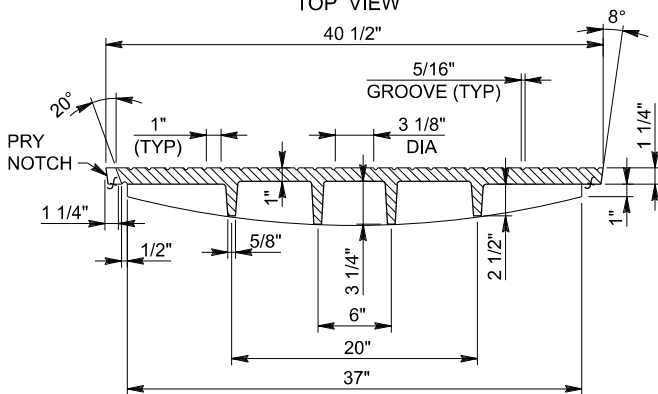

SECTION A-A

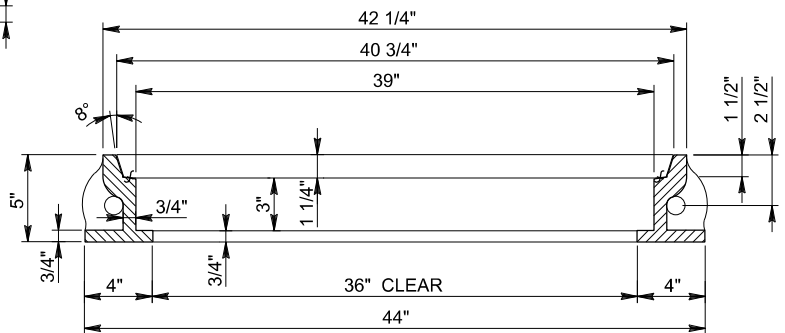

SECTION B-B

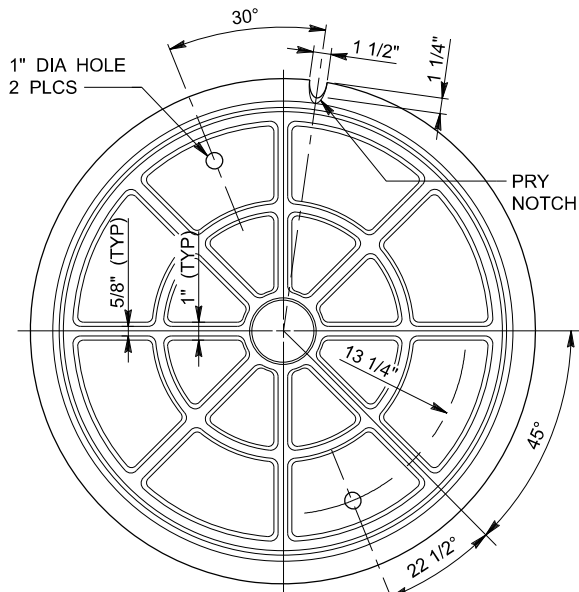

PLAN OF COVER

BOTTOM VIEW

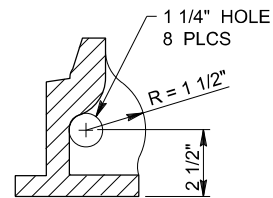

DETAIL

LIFTING EAR & RIB

NOTES:

1. CAST IRON USED SHALL CONFORM WITH ASTM A-48 CLASS 35B.
2. FRAME AND COVER SHALL BE COATED WITH ASPHALTUM OR BITUMINOUS PAINT AFTER TESTING AND INSPECTION.
3. FRAME AND COVER SHALL BE TESTED FOR ACCURATE FIT PRIOR TO DELIVERY AND SHALL BE MARKED IN SETS.
4. ALL CASTINGS SHALL COMPLY WITH SECTION 206-3 OF THE STANDARD SPECIFICATIONS.

COUNTY SANITATION DISTRICTS OF LOS ANGELES COUNTY
OFFICE OF CHIEF ENGINEER

ROBERT FERRANTE
CHIEF ENGINEER

**STANDARD 36" MANHOLE FRAME
AND COVER**

STANDARD DRAWING
2021 EDITION
S - a - 2 1 5
SHEET 1 OF 1

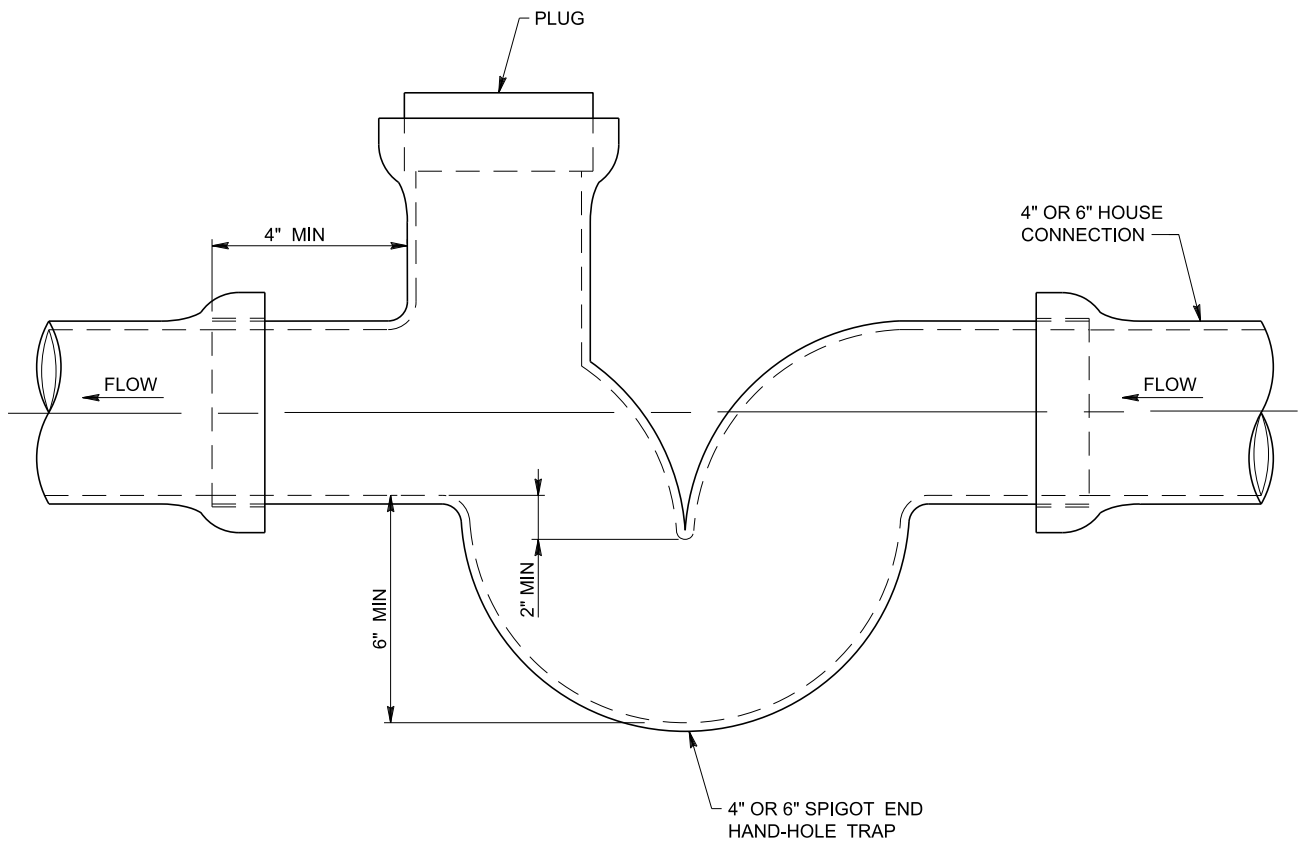

NOTES:

1. GAS TRAP SHALL BE INSTALLED ALONG HOUSE CONNECTION TWO (2) FEET OUTSIDE THE BUILDING AT PROPERTY OWNER'S EXPENSE.
2. GAS TRAPS SHALL BE VITRIFIED CLAY, CAST IRON, PVC, OR ABS PIPE. THE CONTRACTOR SHALL SUBMIT DETAILS OF THE LAYOUT FOR ABS OR PVC GAS TRAPS TO THE DISTRICTS FOR APPROVAL PRIOR TO COMMENCING WORK. ALTERNATE MATERIAL MAY BE USED WHEN APPROVED BY DISTRICTS' INSPECTOR.

COUNTY SANITATION DISTRICTS OF LOS ANGELES COUNTY
OFFICE OF CHIEF ENGINEER

ROBERT FERRANTE
CHIEF ENGINEER

**STANDARD HOUSE CONNECTION
GAS TRAP**

STANDARD DRAWING
2021 EDITION
S - a - 2 1 6
SHEET 1 OF 1

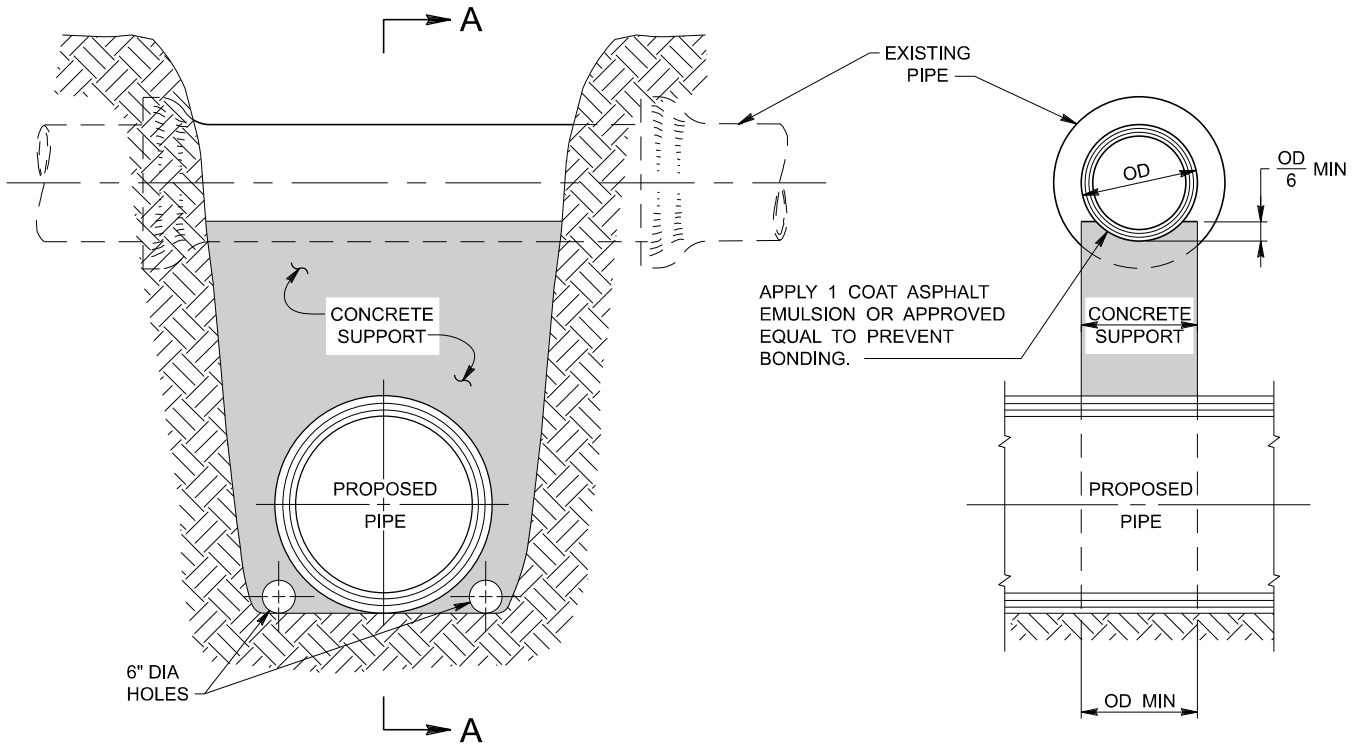

ELEVATION

SECTION A-A

NOTES:

1. CONCRETE SUPPORT SHALL BE POURED AGAINST UNDISTURBED SOIL ON THE BOTTOM AND SHALL EXTEND THE FULL WIDTH OF EXCAVATION.
2. CONCRETE SHALL BE 420-C-2000. WHEN APPROVED BY THE ENGINEER, THE CONTRACTOR MAY SUBSTITUTE CONCRETE WITH 2-SACK CEMENT SLURRY.
3. CONTRACTOR SHALL OBTAIN APPROVAL FROM THE ENGINEER OF HIS PROPOSED METHOD OF SUPPORTING THE EXISTING PIPE DURING CONSTRUCTION.
4. CONTRACTOR SHALL PROVIDE CONCRETE PIPE SUPPORT UNDER ALL EXISTING CONCRETE, ASBESTOS CEMENT, CLAY, TELEPHONE AND POWER CONDUITS AND UNDER ALL OTHER CONDUITS WHERE REQUIRED ON THE PLANS OR REQUESTED BY OWNER.

COUNTY SANITATION DISTRICTS OF LOS ANGELES COUNTY
OFFICE OF CHIEF ENGINEER

ROBERT FERRANTE
CHIEF ENGINEER

STANDARD CONCRETE PIPE SUPPORT

STANDARD DRAWING
2021 EDITION
S - a - 2 1 7
SHEET 1 OF 1

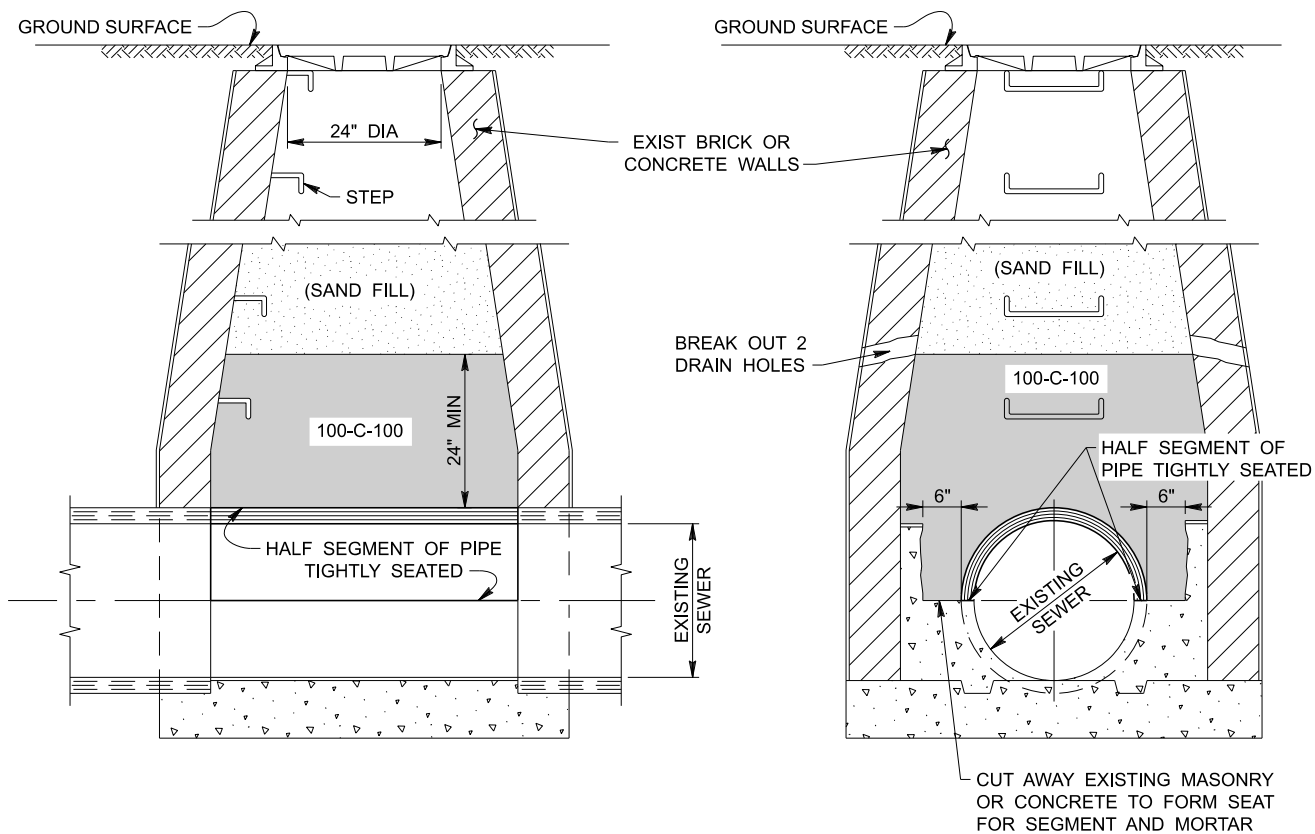

LONGITUDINAL SECTION

CROSS SECTION

NOTES:

1. FORTY-EIGHT HOURS PRIOR TO COMMENCING THE ABANDONMENT OF THE MANHOLE, THE CONTRACTOR SHALL CONTACT THE DISTRICTS' SUPERINTENDENT OF MAINTENANCE AT (310) 638-1161.
2. NO WORK SHALL BE DONE ON MANHOLE EXCEPT IN THE PRESENCE OF THE DISTRICTS' REPRESENTATIVE.
3. MANHOLE FRAME AND COVER SHALL BE SALVAGED, CLEANED AND DELIVERED TO THE DISTRICTS' COMPTON FIELD OFFICE, 920 SOUTH ALAMEDA STREET, COMPTON, CALIFORNIA 90221.
4. THE CONTRACTOR SHALL REMOVE A MINIMUM OF 4 FEET OF THE MANHOLE SHAFT BELOW GROUND SURFACE.
5. IF THE LOWER PORTION OF THE EXISTING CHANNEL THROUGH THE MANHOLE IS NOT AS SHOWN. THE CHANNEL SHALL BE REFORMED AS DIRECTED BY THE DISTRICTS' REPRESENTATIVE.
6. HALF SEGMENT OF PIPE SHALL BE OF THE TYPE USED IN THE SEWER.

COUNTY SANITATION DISTRICTS OF LOS ANGELES COUNTY
OFFICE OF CHIEF ENGINEER

ROBERT FERRANTE
CHIEF ENGINEER

**STANDARD ABANDONMENT OF EXISTING
MANHOLES TYPE "A" OR "D"**

STANDARD DRAWING
2021 EDITION
S - a - 2 1 8
SHEET 1 OF 1

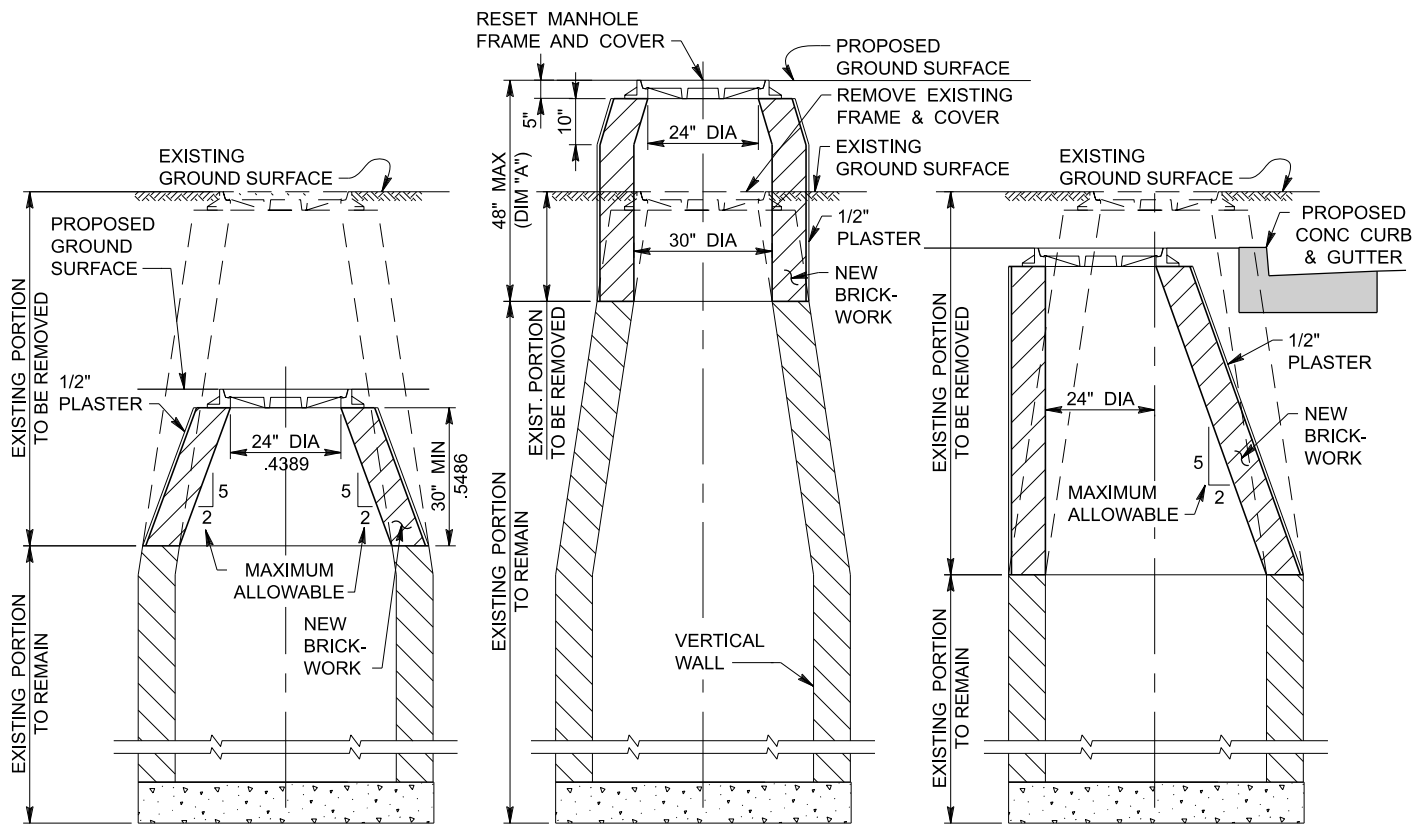

CASE I

CASE II

CASE III

NOTES:

1. PRIOR TO THE REMOVAL OF THE FRAME OF ANY MANHOLE, THE CHANNEL OF THE MANHOLE SHALL BE COMPLETELY COVERED WITH PLANKING OR OTHER SUITABLE MATERIAL SO AS TO PREVENT DEBRIS FROM ENTERING THE CHANNEL. AFTER THE MANHOLE RECONSTRUCTION HAS BEEN COMPLETED ALL DEBRIS SHALL BE REMOVED FROM WITHIN THE MANHOLE AND THE COVER OVER THE CHANNEL SHALL BE REMOVED.
2. WHEN THE MANHOLE IS TO BE RECONSTRUCTED TO A STRAIGHT SIDED MANHOLE, THE BRICK WORK SHALL BE REMOVED TO THE HIGHEST POINT OF THE VERTICAL WALL. THE SLOPE OF THE CORBELED SIDE SHALL NOT EXCEED 2 INCHES IN 5 INCHES. THE MANHOLE STEPS SHALL BE PLACED ON THE VERTICAL SIDE. SEE CASE III.
3. WHEN THE MANHOLE IS TO BE RAISED AN AMOUNT SUCH THAT DIMENSION "A" (CASE II) IS LESS THAN 4', THE BRICKWORK SHALL BE REMOVED TO A POINT WHERE THE INSIDE DIAMETER IS A MINIMUM OF 30 INCHES. THE MANHOLE WALL SHALL THEN BE CONSTRUCTED VERTICALLY TO A POINT 15 INCHES BELOW THE TOP OF THE MANHOLE. SEE CASE II.
4. WHERE THE MANHOLE IS TO BE RAISED SUCH THAT DIMENSION "A" (CASE II) WOULD EXCEED 4', THE BRICKWORK SHALL BE REMOVED TO THE HIGHEST POINT OF THE VERTICAL WALL AND THE MANHOLE RECONSTRUCTED PER S-a-201 OR S-a-204.
5. WHEN THE DEPTH OF THE MANHOLE TO BE LOWERED IS SUCH THAT THE MAXIMUM ALLOWABLE SLOPES FOR THE BRICKWORK SHOWN FOR CASE I WOULD BE EXCEEDED, THE MANHOLE SHALL BE RECONSTRUCTED AS A TYPE "C" MANHOLE PER S-a-203.
6. MANHOLE STEPS, PER S-a-209, SHALL BE PLACED UNIFORMLY SO AS NOT TO BE MORE THAN 16 INCHES APART WITH THE TOP STEP BEING 16 INCHES BELOW THE MANHOLE FRAME.
7. PRIOR TO COMMENCING WORK OF RECONSTRUCTION, THE CONTRACTOR SHALL CONTACT THE DISTRICTS' SUPERINTENDENT OF MAINTENANCE AT (310) 638-1161.

COUNTY SANITATION DISTRICTS OF LOS ANGELES COUNTY
OFFICE OF CHIEF ENGINEER

ROBERT FERRANTE
CHIEF ENGINEER

**STANDARD RECONSTRUCTION
OF BRICK MANHOLES**

STANDARD DRAWING
2021 EDITION
S - a - 2 1 9
SHEET 1 OF 1

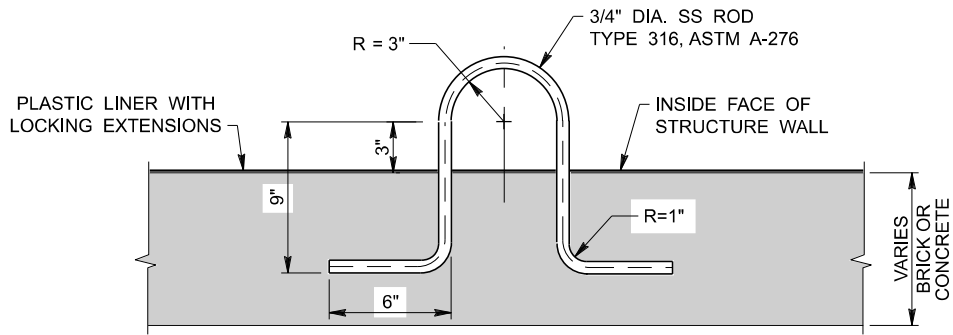

**FOR CONCRETE STRUCTURE OR
TYPE "A" MANHOLE WALL**

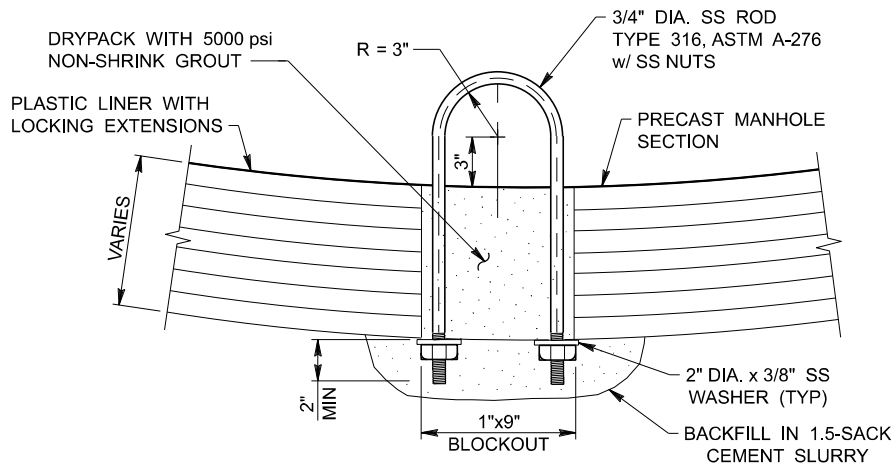

**FOR PRECAST MANHOLE SECTION OR
CONCRETE WALL 8" OR LESS**

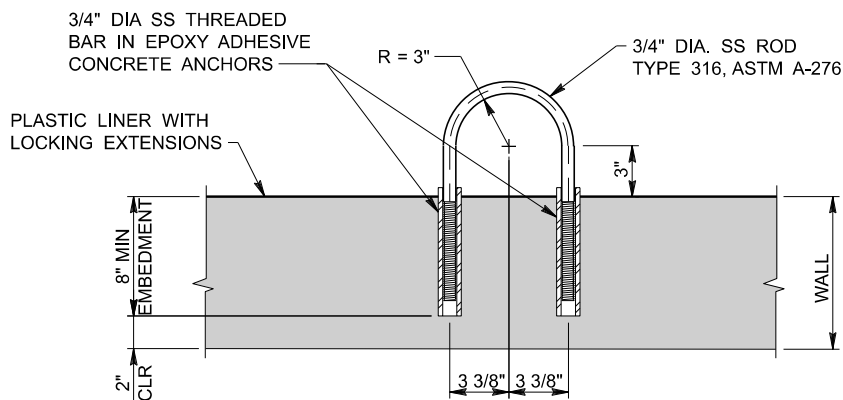

**ALTERNATE PULL RING FOR
CONCRETE STRUCTURE**

NOTE:
SEE NOTE 3 OF S-a-202
FOR PLASTIC LINER JOINT
SEALING REQUIREMENTS AT
PULL RING PENETRATIONS.

COUNTY SANITATION DISTRICTS OF LOS ANGELES COUNTY
OFFICE OF CHIEF ENGINEER

ROBERT FERRANTE
CHIEF ENGINEER

STANDARD PULL RING

STANDARD DRAWING
2021 EDITION
S - a - 2 2 0
SHEET 1 OF 1

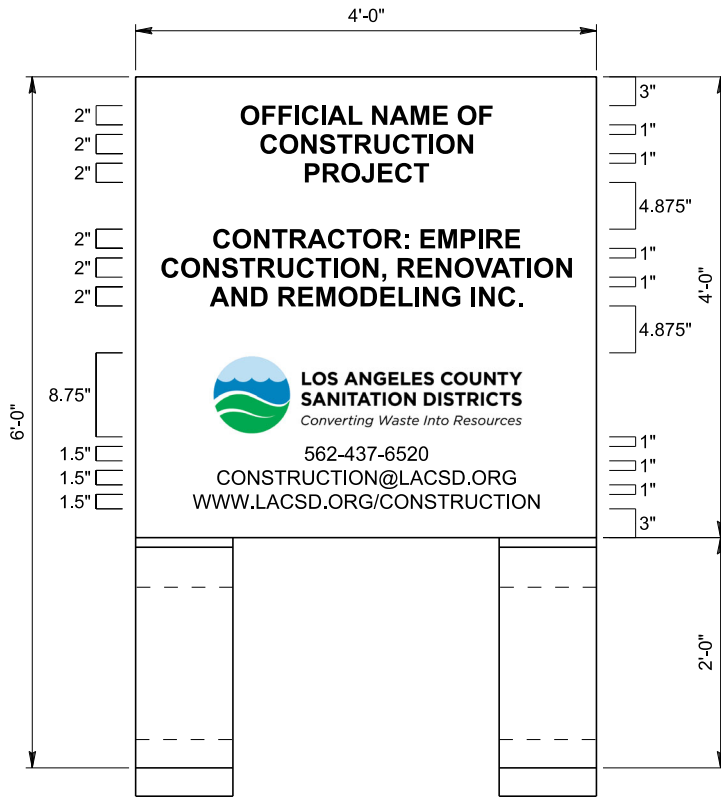

FRONT VIEW

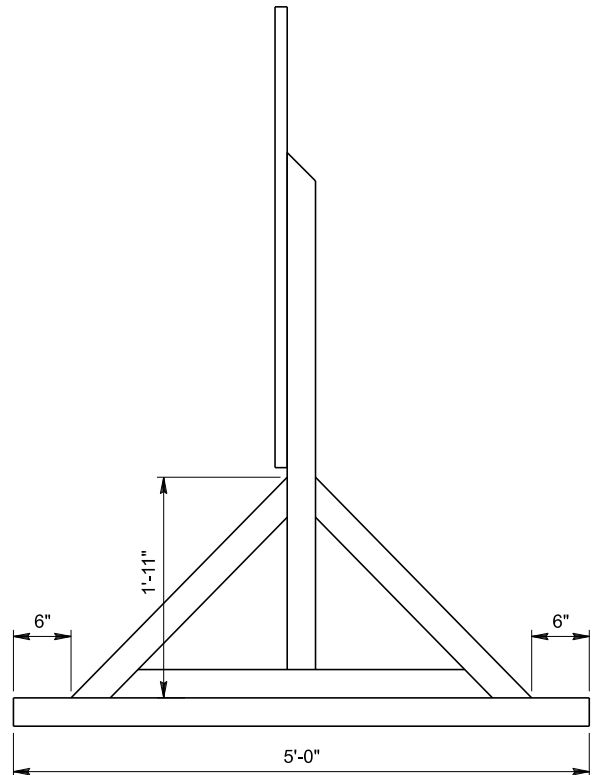

SIDE VIEW

NOTES:

1. ALL FRAMING LUMBER SHALL BE 2" x 6" S4S D.F.
2. ENTIRE SIGN, INCLUDING FRAMING, SHALL BE PAINTED WITH TWO COATS OF EXTERIOR OIL BASE WHITE PAINT.
3. LETTERING SHALL BE DONE IN BLACK BY QUALIFIED SIGN PAINTER AND TO THE SATISFACTION OF THE ENGINEER.
4. SIGNS SHALL BE MAINTAINED IN A CONDITION SATISFACTORY TO THE ENGINEER.
5. SIGNS SHALL BE FURNISHED, INSTALLED AND MOVED BY CONTRACTOR AS DIRECTED BY THE ENGINEER. NO CONSTRUCTION SHALL COMMENCE UNTIL SIGNS ARE IN PLACE. TWO REQUIRED.
6. DISTRICTS WILL PROVIDE LOGO AND ADDITIONAL SIGN DETAILS TO THE CONTRACTOR AT THE PRECONSTRUCTION MEETING.

COUNTY SANITATION DISTRICTS OF LOS ANGELES COUNTY
OFFICE OF CHIEF ENGINEER

ROBERT FERRANTE
CHIEF ENGINEER

STANDARD PROJECT SIGN

STANDARD DRAWING
2021 EDITION
S - a - 2 2 1
SHEET 1 OF 1

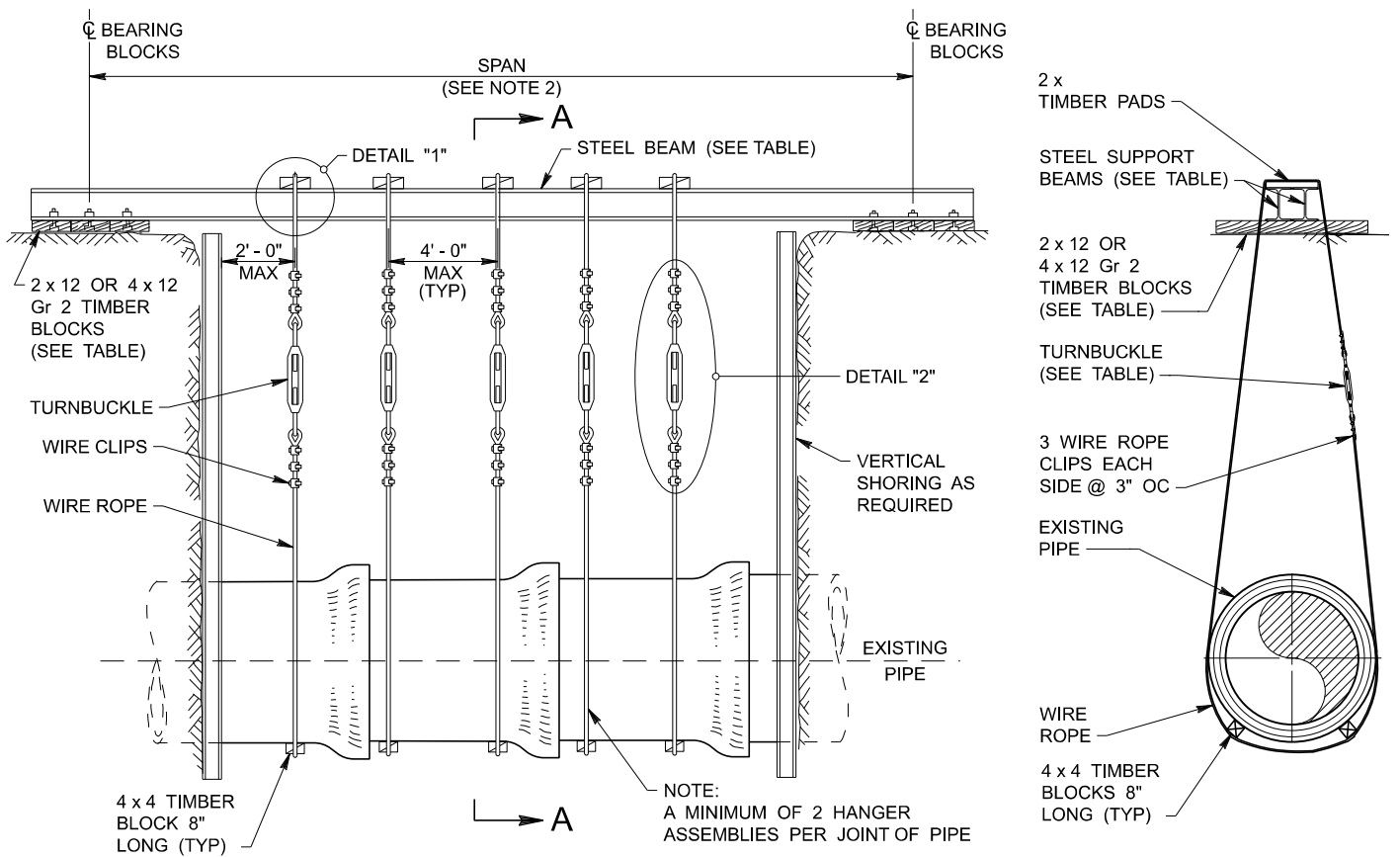

ELEVATION

SECTION A-A

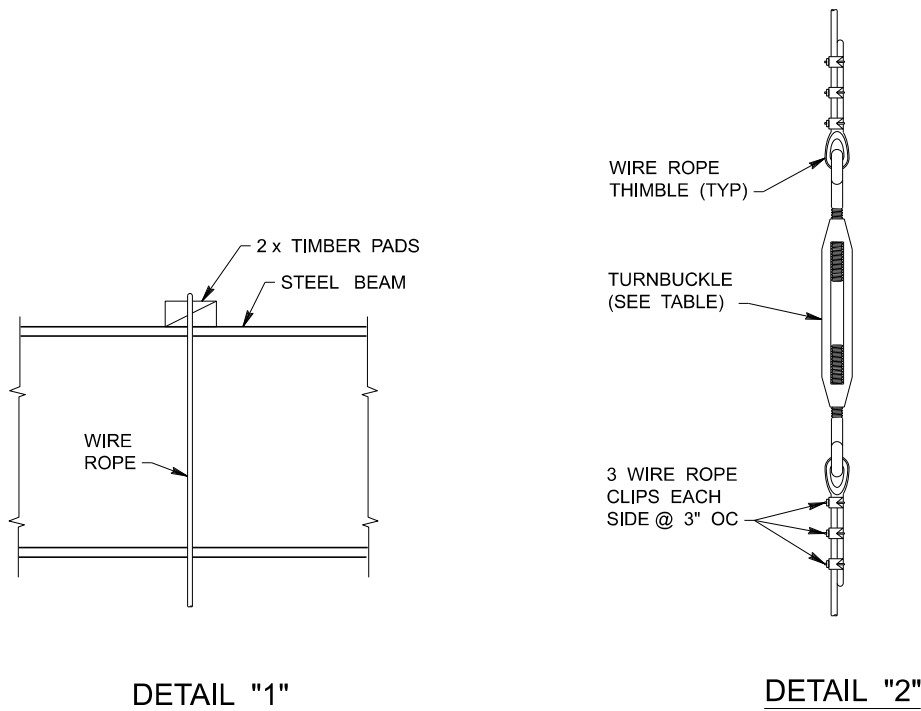

COUNTY SANITATION DISTRICTS OF LOS ANGELES COUNTY
OFFICE OF CHIEF ENGINEER

ROBERT FERRANTE
CHIEF ENGINEER

STANDARD TEMPORARY PIPE SUPPORT

STANDARD DRAWING
2021 EDITION
S - a - 2 2 2
SHEET 1 OF 2

TABLE OF MEMBER SIZES (PART I)							
PIPE SIZE	STEEL BEAMS					WIRE ROPE	TURNBUCKLE
	SPAN						
	0' - 10'	11' - 15'	16' - 20'	21' - 30'	31' - 40'		
8" - 10"	w 6 x 9	w 6 x 9	w 6 x 9	w 8 x 18	w 10 x 22	3/8"	1/2"
12" - 15"	w 6 x 9	w 6 x 15	w 6 x 20	w 10 x 22	w 12 x 30	3/8"	1/2"
18" - 21"	w 6 x 9	w 8 x 18	w 8 x 24	w 10 x 33	w 12 x 53	3/8"	1/2"
24" - 27"	w 6 x 15	w 8 x 18	w 8 x 28	w 12 x 40	w 12 x 72	3/8"	1/2"
30"	w 6 x 15	w 8 x 18	w 8 x 31	w 12 x 53	2 - w 12 x 53	1/2"	5/8"
33"	w 8 x 18	w 8 x 24	w 10 x 33	w 12 x 65	2 - w 12 x 65	1/2"	5/8"
36"	w 8 x 18	w 10 x 22	w 10 x 33	w 12 x 72	2 - w 12 x 65	1/2"	5/8"
39"	w 8 x 18	w 10 x 22	w 10 x 39	w 12 x 72	2 - w 12 x 72	1/2"	5/8"
42"	w 8 x 18	w 10 x 22	w 10 x 49	w 12 x 79	2 - w 14 x 61	1/2"	5/8"
48"	w 8 x 18	w 12 x 30	w 12 x 53	—	—	1/2"	5/8"
54"	w 10 x 22	w 12 x 30	w 12 x 53	—	—	5/8"	3/4"
60"	w 10 x 22	w 12 x 40	w 12 x 65	—	—	5/8"	3/4"
66"	w 10 x 33	w 12 x 53	2 - w 12 x 53	—	—	5/8"	3/4"
72"	w 12 x 30	w 12 x 53	2 - w 12 x 65	—	—	5/8"	7/8"

TABLE OF MEMBER SIZES (PART II)						
PIPE SIZE	TIMBER BEARING BLOCKS					
	SPAN					
	0' - 10'	11' - 15'	16' - 20'	21' - 30'	31' - 40'	
8" - 10"	1 - 2 x 12 x 2'	1 - 2 x 12 x 2'	2 - 2 x 12 x 2'	2 - 2 x 12 x 2'	2 - 2 x 12 x 2'	
12" - 15"	1 - 2 x 12 x 2'	1 - 2 x 12 x 2'	2 - 2 x 12 x 2'	2 - 2 x 12 x 2'	2 - 4 x 12 x 3'	
18" - 21"	1 - 2 x 12 x 2'	1 - 2 x 12 x 3'	2 - 2 x 12 x 3'	2 - 4 x 12 x 3'	2 - 4 x 12 x 4'	
24" - 27"	1 - 2 x 12 x 3'	2 - 2 x 12 x 2'	2 - 2 x 12 x 3'	2 - 4 x 12 x 5'	3 - 4 x 12 x 4'	
30"	1 - 2 x 12 x 3'	2 - 2 x 12 x 3'	2 - 4 x 12 x 4'	3 - 4 x 12 x 4'	3 - 4 x 12 x 5'	
33"	2 - 2 x 12 x 2'	2 - 2 x 12 x 3'	2 - 4 x 12 x 4'	3 - 4 x 12 x 5'	3 - 4 x 12 x 6'	
36"	2 - 2 x 12 x 2'	2 - 2 x 12 x 3'	2 - 4 x 12 x 4'	3 - 4 x 12 x 5'-6"	4 - 4 x 12 x 5'-6"	
39"	2 - 2 x 12 x 3'	2 - 4 x 12 x 4'	2 - 4 x 12 x 5'	4 - 4 x 12 x 5'	4 - 4 x 12 x 6'	
42"	2 - 2 x 12 x 3'	2 - 4 x 12 x 4'	2 - 4 x 12 x 5'	4 - 4 x 12 x 5'-6"	4 - 4 x 12 x 6'-6"	
48"	2 - 4 x 12 x 4'	2 - 4 x 12 x 5'	3 - 4 x 12 x 5'	—	—	
54"	2 - 4 x 12 x 4'	2 - 4 x 12 x 5'	3 - 4 x 12 x 5'	—	—	
60"	2 - 4 x 12 x 4'	3 - 4 x 12 x 5'	3 - 4 x 12 x 5'	—	—	
66"	2 - 4 x 12 x 5'	3 - 4 x 12 x 5'	3 - 4 x 12 x 6'	—	—	
72"	2 - 4 x 12 x 5'	3 - 4 x 12 x 5'	4 - 4 x 12 x 5'	—	—	

NOTES:

1. FORTY-EIGHT HOURS PRIOR TO COMMENCING CONSTRUCTION OF THE TEMPORARY SUPPORT, THE CONTRACTOR SHALL CONTACT THE DISTRICTS' SUPERINTENDENT OF MAINTENANCE AT (310) 638-1161.
2. APPROVAL SHALL BE OBTAINED FROM THE DISTRICTS' REPRESENTATIVE OF THE SPAN TO BE USED IN DETERMINING THE SIZE OF THE STEEL BEAM.
3. ALL WORK ON THE TEMPORARY SUPPORT SHALL BE DONE ONLY IN THE PRESENCE OF THE DISTRICTS' REPRESENTATIVE.
4. THE CONTRACTOR SHALL BE COMPLETELY RESPONSIBLE FOR THE ADEQUACY OF THE TEMPORARY SUPPORT AND FOR THE MANNER IN WHICH IT IS INSTALLED.
5. FOR PIPES AND MEMBER SIZES NOT SHOWN IN THE ABOVE TABLES, THE CONTRACTOR SHALL SUBMIT DETAILS OF THE PROPOSED SUPPORT AND CALCULATIONS PREPARED BY A CIVIL OR STRUCTURAL ENGINEER REGISTERED IN THE STATE OF CALIFORNIA TO THE DISTRICTS FOR APPROVAL PRIOR TO COMMENCING CONSTRUCTION.
6. ACCEPTANCE SHALL BE OBTAINED FROM THE DISTRICTS' REPRESENTATIVE PRIOR TO USING MEMBERS OR PARTS OF THE TEMPORARY SUPPORT DIFFERENT THAN DETAILED.
7. LARGER STEEL BEAMS WITH CORRESPONDINGLY LARGER SECTION MODULI MAY BE SUBSTITUTED.

COUNTY SANITATION DISTRICTS OF LOS ANGELES COUNTY
OFFICE OF CHIEF ENGINEER

ROBERT FERRANTE
CHIEF ENGINEER

STANDARD TEMPORARY PIPE SUPPORT

STANDARD DRAWING
2021 EDITION
S - a - 2 2 2
SHEET 2 OF 2

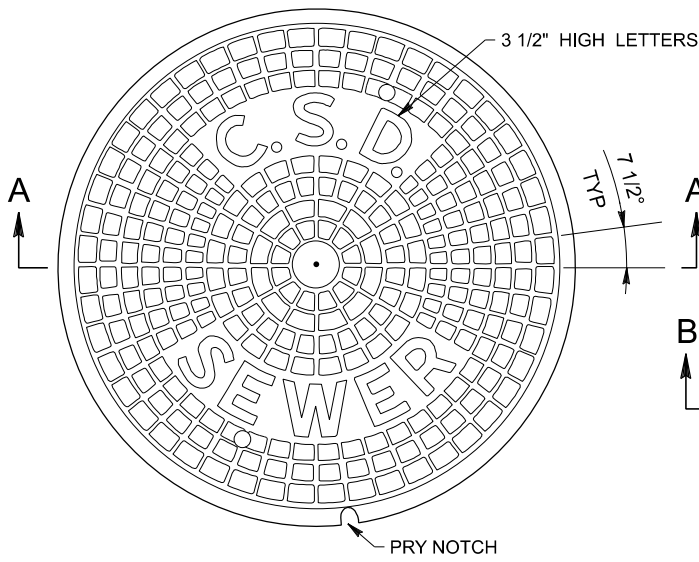

PLAN OF COVER
TOP VIEW

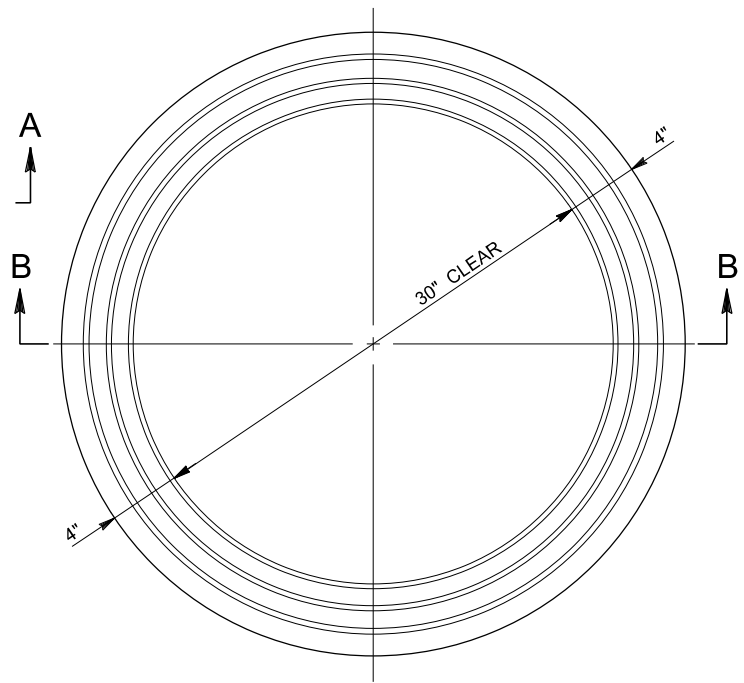

PLAN OF FRAME

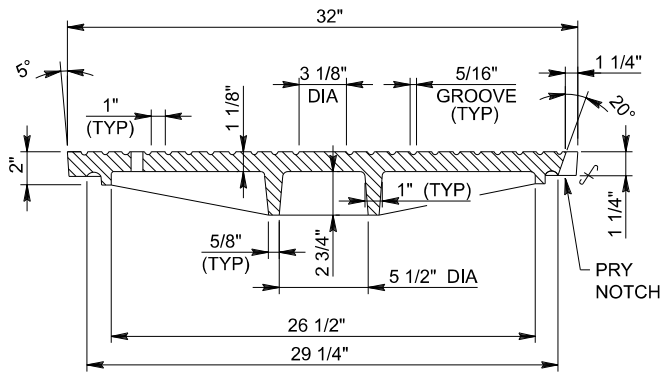

SECTION A-A

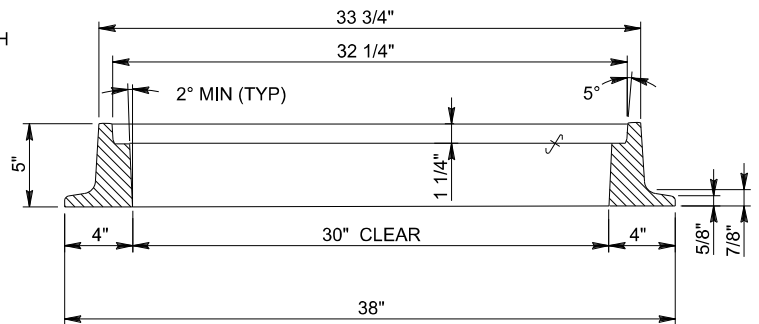

SECTION B-B

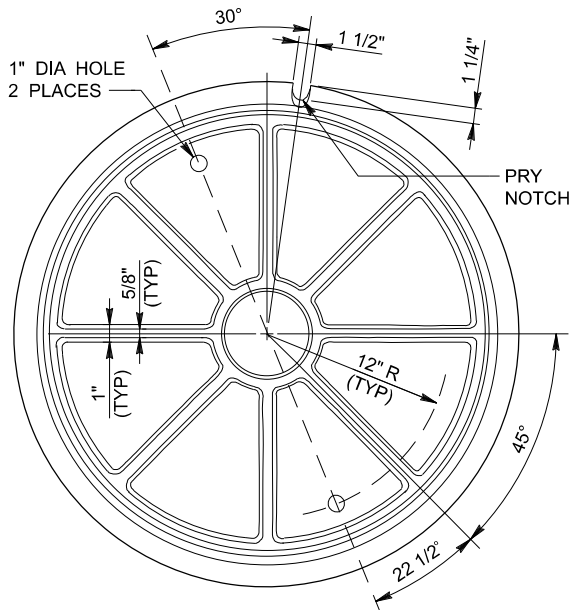

PLAN OF COVER
BOTTOM VIEW

NOTES:

1. CAST IRON USED SHALL CONFORM WITH ASTM A-48 CLASS 35B.
2. FRAME AND COVER SHALL BE COATED WITH ASPHALTUM OR BITUMINOUS PAINT AFTER TESTING AND INSPECTION.
3. FRAME AND COVER SHALL BE TESTED FOR ACCURATE FIT PRIOR TO DELIVERY AND SHALL BE MARKED IN SETS.
4. ALL CASTINGS SHALL COMPLY WITH SECTION 206-3 OF THE STANDARD SPECIFICATIONS.

COUNTY SANITATION DISTRICTS OF LOS ANGELES COUNTY
OFFICE OF CHIEF ENGINEER

ROBERT FERRANTE
CHIEF ENGINEER

**STANDARD 30" MANHOLE FRAME
AND COVER**

STANDARD DRAWING
2021 EDITION
S - a - 2 2 3
SHEET 1 OF 1

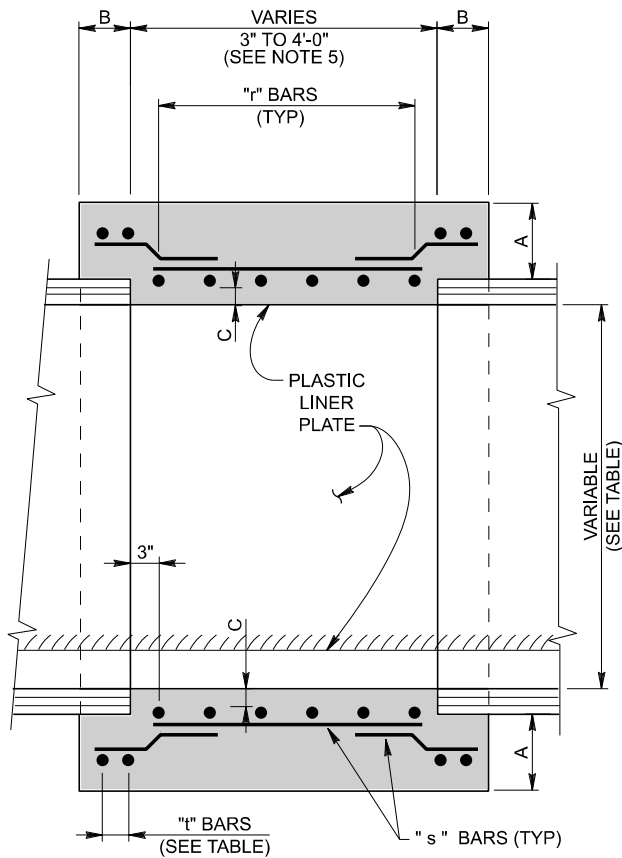

LONGITUDINAL SECTION

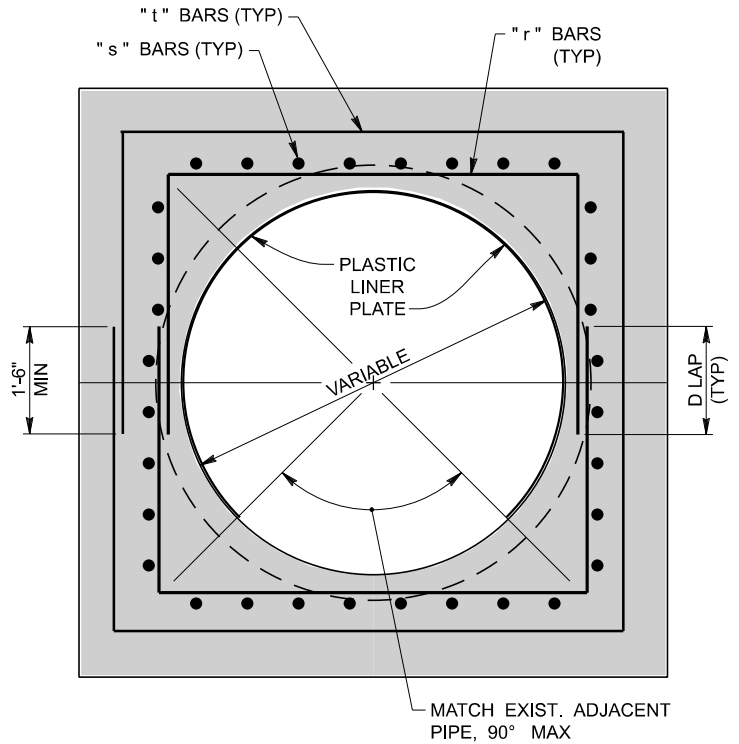

CROSS SECTION

TABLE OF REINFORCING BARS

PIPE SIZE	DEPTH TO INVERT	DIMENSIONS				REINFORCING BARS		
		A	B	C	D	" r "	" s "	" t "
24" TO 33"	0' TO 15'	6"	8"	3"	16"	#4 @ 10"	#4 @ 12	2 - #4
	16' TO 30'				#4 @ 10	#4 @ 8	2 - #4	
36"	0' TO 15'	6"	8"	3"	16"	#4 @ 10	#4 @ 12	2 - #4
	16' TO 30'				#4 @ 6	#4 @ 12	2 - #4	
39"	0' TO 15'	6"	8"	3"	16"	#4 @ 10	#4 @ 12	2 - #4
	16' TO 30'				#4 @ 6	#4 @ 12	2 - #4	
42"	0' TO 15'	7"	8"	3"	16"	#4 @ 10	#5 @ 12	2 - #5
	16' TO 30'				20"	#5 @ 10	#5 @ 12	2 - #5
48"	0' TO 15'	7"	8"	4"	16"	#4 @ 10	#5 @ 12	2 - #5
	16' TO 30'				20"	#5 @ 8	#5 @ 12	2 - #5
54"	0' TO 15'	7"	8"	4"	16"	#4 @ 8	#5 @ 12	2 - #5
	16' TO 30'				20"	#5 @ 8	#5 @ 12	2 - #5
60"	0' TO 15'	8"	8"	4"	16"	#4 @ 6	#5 @ 12	2 - #5
	16' TO 30'				24"	#6 @ 8	#5 @ 12	2 - #5
66"	0' TO 15'	8"	10"	5"	20"	#5 @ 8	#5 @ 12	3 - #5
	16' TO 30'				28"	#7 @ 8	#5 @ 12	3 - #5
72"	0' TO 15'	8"	10"	5"	20"	#5 @ 8	#5 @ 12	3 - #5
	16' TO 30'				28"	#7 @ 6	#5 @ 12	3 - #5
84"	0' TO 15'	9"	12"	5"	20"	#5 @ 8	#5 @ 12	3 - #6
	15' TO 30'				28"	#7 @ 6	#5 @ 12	3 - #6
96"	0' TO 15'	9"	12"	6"	20"	#5 @ 6	#5 @ 9	3 - #6
	15' TO 30'				28"	#7 @ 6	#5 @ 9	3 - #6

NOTES:

1. CONCRETE SHALL BE 660-B-4000.
2. ALL REINFORCING BARS SHALL BE ASTM A-706, CLASS 60.
3. THE CONCRETE SHALL BE CONSOLIDATED BY MEANS OF HIGH FREQUENCY INTERNAL VIBRATORS.
4. DETAIL APPLIES FOR PIPES WITH COVER FROM 3'-0" TO 30'-0" FOR TRENCH CONDITION AND FOR PIPES WITH COVER 3'-0" TO 10'-0" FOR EMBANKMENT CONDITION.
5. PIPE BARRELLING SHALL BE DONE AT LOCATIONS AND LENGTHS SHOWN ON THE DRAWINGS OR AUTHORIZED BY THE ENGINEER.

COUNTY SANITATION DISTRICTS OF LOS ANGELES COUNTY
OFFICE OF CHIEF ENGINEER

ROBERT FERRANTE
CHIEF ENGINEER

STANDARD PIPE BARREL

STANDARD DRAWING
2021 EDITION
S - a - 2 2 4
SHEET 1 OF 1

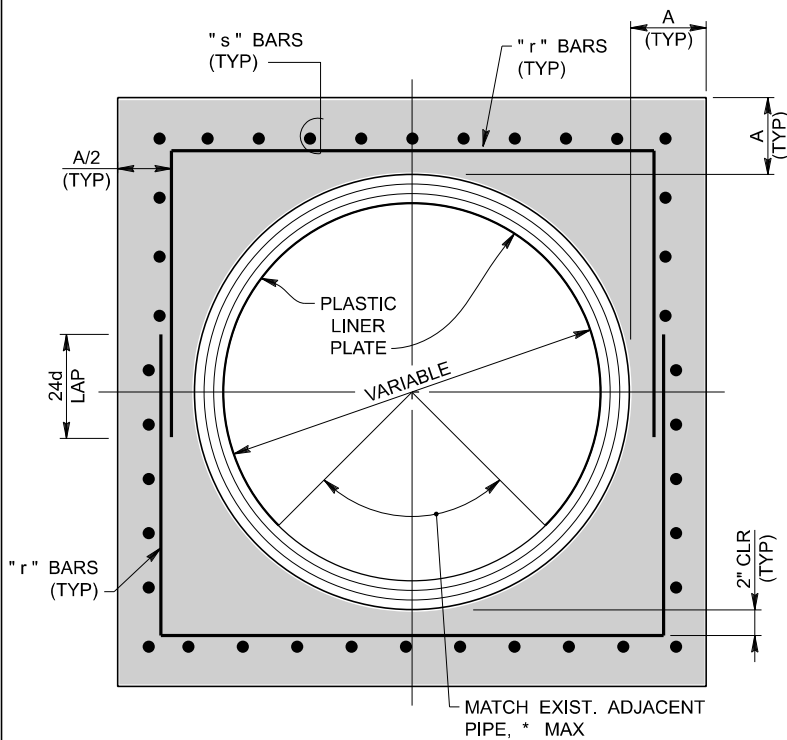

CROSS SECTION

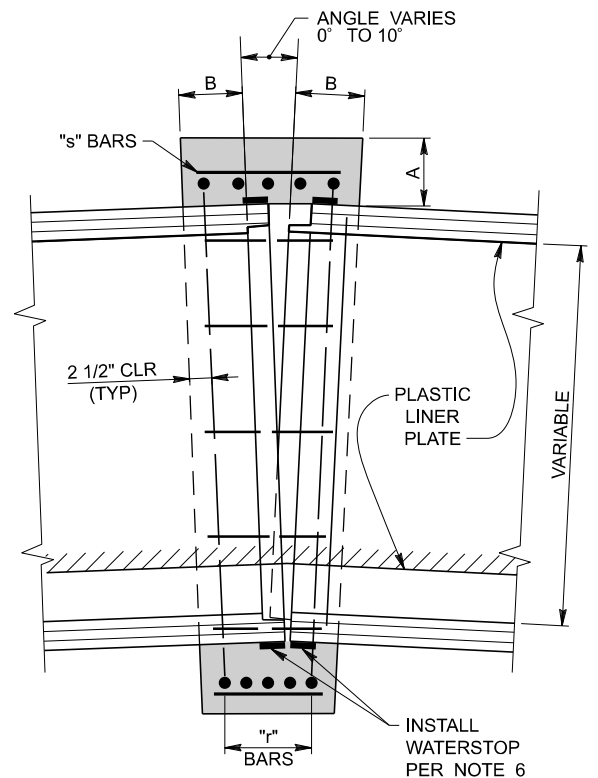

LONGITUDINAL SECTION

TABLE OF REINFORCING BARS				
PIPE DIAMETER	DIMENSIONS		REINFORCING BARS	
	A	B	"r"	"s"
24" TO 36"	8"	8"	#4 @ 8	#4 @ 12
39" TO 57"	8"	10"	#6 @ 8	#5 @ 12
60" TO 78"	10"	12"	#7 @ 6	#5 @ 12
84" TO 96"	12"	16"	#7 @ 6	#5 @ 9"

NOTES:

1. CONSTRUCT CONCRETE COLLAR WHERE REQUIRED ON THE PLANS AND AT ALL PIPE JOINTS WHERE THERE IS A CHANGE IN THE TYPE OF JOINT OR A CHANGE IN THE THICKNESS OF THE WALLS OF ADJACENT PIPES.
2. UNLESS OTHERWISE SPECIFIED, CONCRETE SHALL BE 660-B-4000 AND ALL REINFORCING BARS SHALL BE DEFORMED BARS CONFORMING TO ASTM-A706 GRADE 60.
3. EXTERIOR SURFACES OF CONCRETE PIPE SHALL BE CLEANED BY SANDBLASTING PRIOR TO PLACING CONCRETE.
4. THE CONTRACTOR SHALL SUBMIT WORKING DRAWINGS THAT SHOW DETAILS FOR JOINING ANY PLASTIC LINERS IN ADJACENT PIECES OF PIPE.
5. FOR VITRIFIED CLAY PIPE HAVING NO ANGULAR DEFLECTION, THE CONTRACTOR MAY USE A REPAIR COUPLING AND OMIT THE REINFORCING STEEL FROM THE CONCRETE COLLAR. THE REPAIR COUPLING SHALL INCLUDE AN INTEGRAL SHEAR BAND. DETAILS OF THE REPAIR COUPLING SHALL BE SUBMITTED TO THE DISTRICTS' FOR APPROVAL.
6. WATERSTOP SHALL BE SIKA HYDROTITE CJ-1020-2K-ADH, ADEKA MC-2010MN OR EQUIVALENT. INSTALL ALL AROUND EACH PIPE.

COUNTY SANITATION DISTRICTS OF LOS ANGELES COUNTY
OFFICE OF CHIEF ENGINEER

ROBERT FERRANTE
CHIEF ENGINEER

STANDARD CONCRETE COLLAR

STANDARD DRAWING
2021 EDITION
S - a - 2 2 5
SHEET 1 OF 1

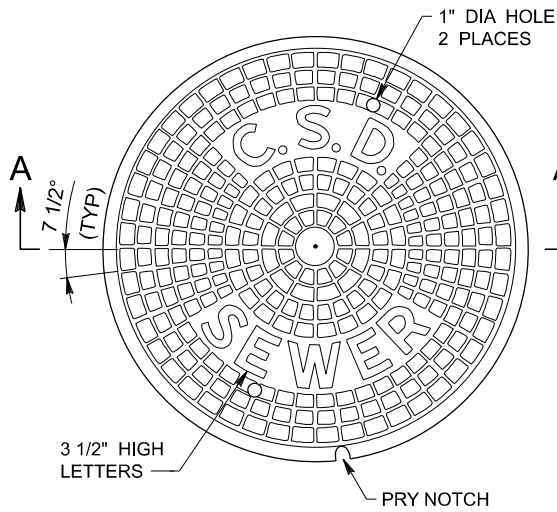

PLAN OF COVER
TOP VIEW

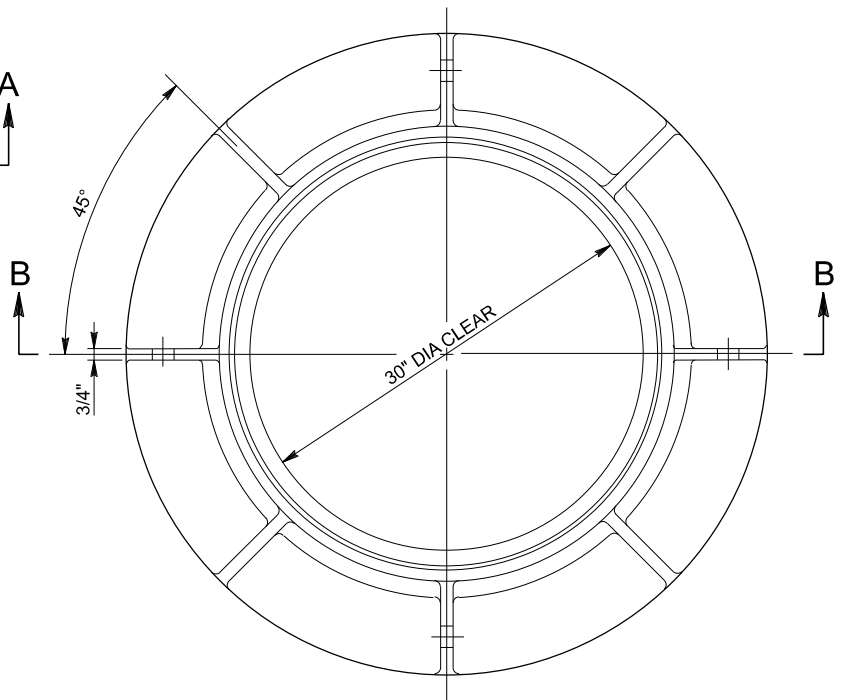

PLAN OF FRAME

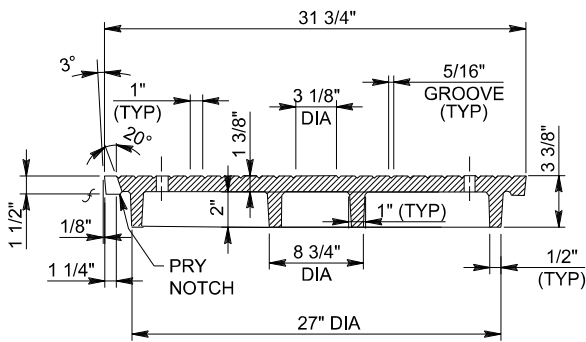

SECTION A-A

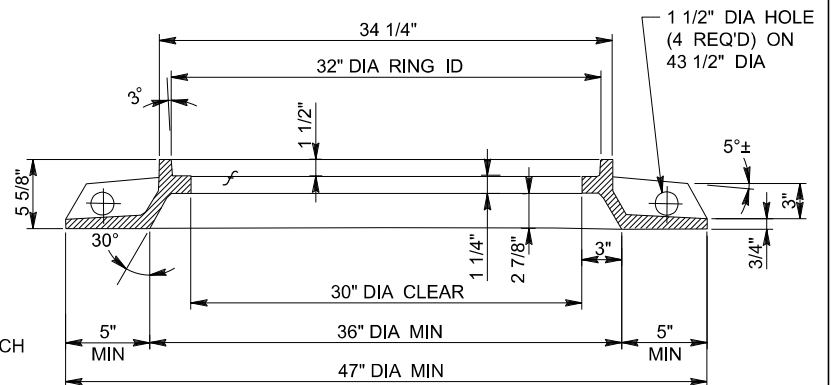

SECTION B-B

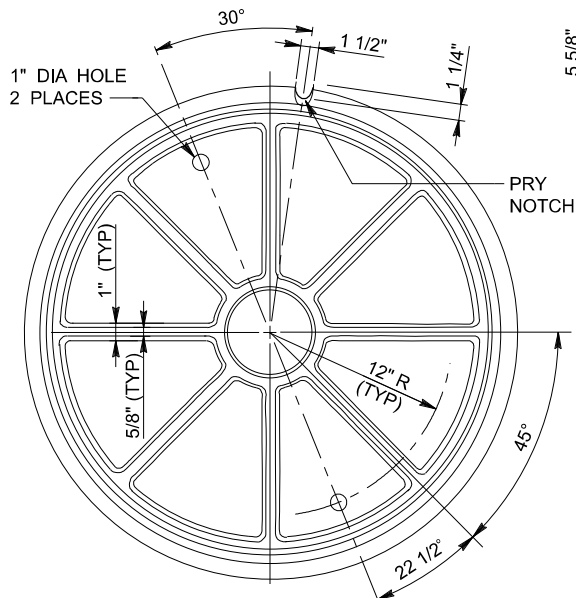

PLAN OF COVER
BOTTOM VIEW

NOTES:

1. CAST IRON USED SHALL CONFORM WITH ASTM A-48 CLASS 35B.
2. FRAME AND COVER SHALL BE COATED WITH ASPHALTUM OR BITUMINOUS PAINT AFTER TESTING AND INSPECTION.
3. FRAME AND COVER SHALL BE TESTED FOR ACCURATE FIT PRIOR TO DELIVERY AND SHALL BE MARKED IN SETS.
4. ALL CASTINGS SHALL COMPLY WITH SECTION 206-3 OF THE STANDARD SPECIFICATIONS.

COUNTY SANITATION DISTRICTS OF LOS ANGELES COUNTY
OFFICE OF CHIEF ENGINEER

ROBERT FERRANTE
CHIEF ENGINEER

**STANDARD 36" MANHOLE FRAME
WITH 30" COVER**

STANDARD DRAWING
2021 EDITION
S - a - 2 2 6
SHEET 1 OF 1

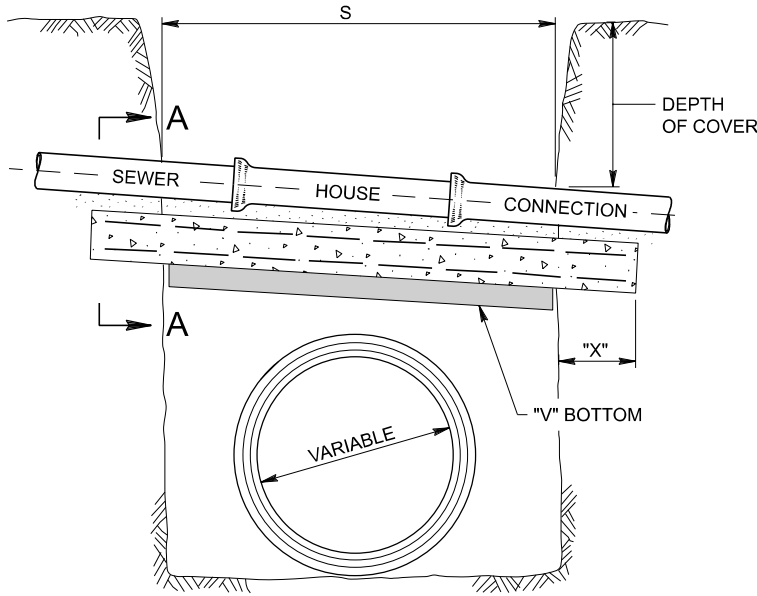

ELEVATION

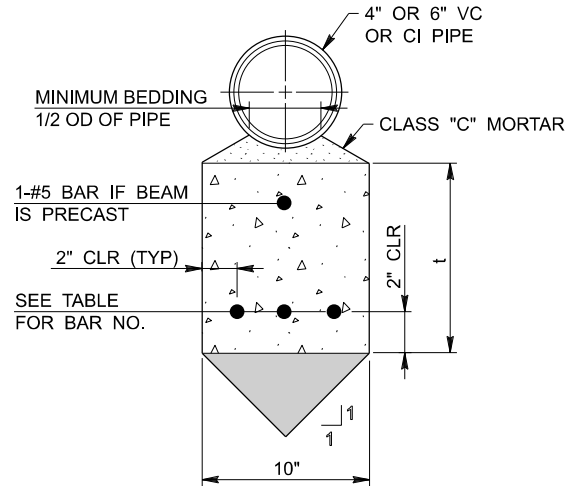

SECTION A-A

DIMENSIONS OF REINFORCED CONCRETE BEAM				
S (FEET)	DEPTH OF COVER			
	0 TO 8'-0"		8'-1" TO 16'-0"	
	t	BAR NO.	t	BAR NO.
4	8"	4	10"	5
5	9"	5	12"	5
6	10"	5	13"	6
7	11"	6	15"	6
8	12"	6	16"	6
9	13"	6	17"	7
10	14"	7	19"	7
11	15"	7	20"	7
12	16"	7	22"	7
13	17"	7	23"	8
14	18"	8	25"	8
15	19"	8	26"	8
16	20"	8	—	—
17	21"	8	—	—
18	22"	8	—	—

NOTE:

1. BEAM CONCRETE SHALL BE 660-B-4000. ALL REINFORCING BARS SHALL BE DEFORMED BARS CONFORMING TO ASTM-A706 GRADE 60. A "V" BOTTOMED BEAM AS DETAILED ABOVE SHALL BE POURED IN PLACE OR, IF APPROVED BY THE ENGINEER, A RECTANGULAR PRECAST BEAM SHALL BE PLACED ON BACKFILL WHICH HAS BEEN PREVIOUSLY CONSOLIDATED TO THE INVERT OF THE HOUSE CONNECTION AND REEXCAVATED TO ACCOMMODATE THE BEAM. IN EITHER CASE, THE BEAM SHALL BEAR ON UNDISTURBED OR CONSOLIDATED SOIL.

MINIMUM LENGTH OF BEARING OF ENDS OF REINFORCED CONCRETE BEAMS		
DEPTH OF COVER	S	MIN BEARING - "X"
0 TO 8'-0"	0 TO 12'-0"	18"
	12'-1" TO 18'-0"	24"
8'-1" TO 16'-0"	0 TO 7'-0"	18"
	7'-1" TO 11'-0"	24"
	11'-1" TO 15'-0"	30"

COUNTY SANITATION DISTRICTS OF LOS ANGELES COUNTY
OFFICE OF CHIEF ENGINEER

ROBERT FERRANTE
CHIEF ENGINEER

STANDARD CONCRETE BEAM FOR HOUSE CONNECTIONS

STANDARD DRAWING
2021 EDITION
S - a - 2 2 7
SHEET 1 OF 1

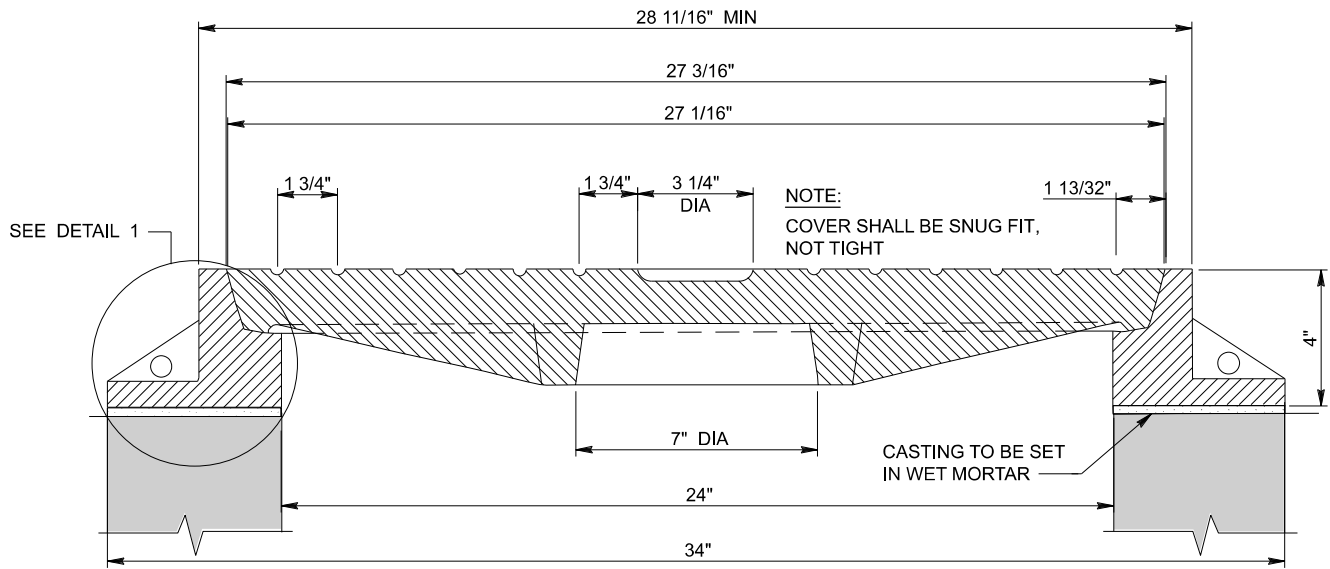

**SECTION
MANHOLE FRAME AND COVER**

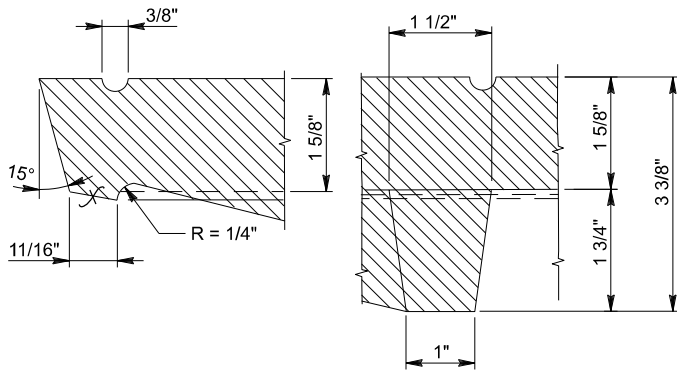

SECTION A-A

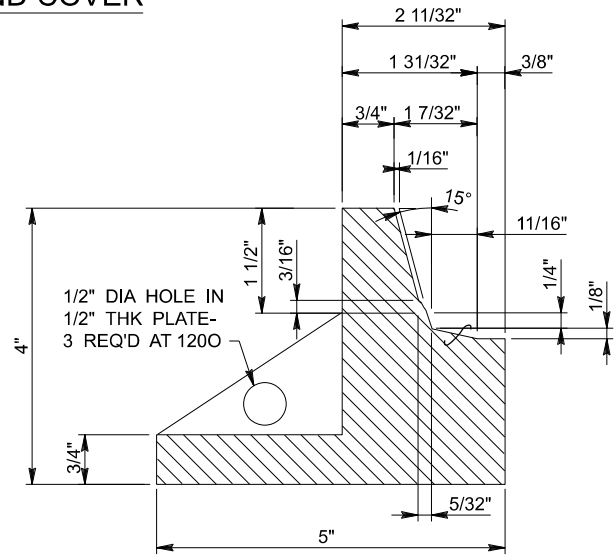

DETAIL 1

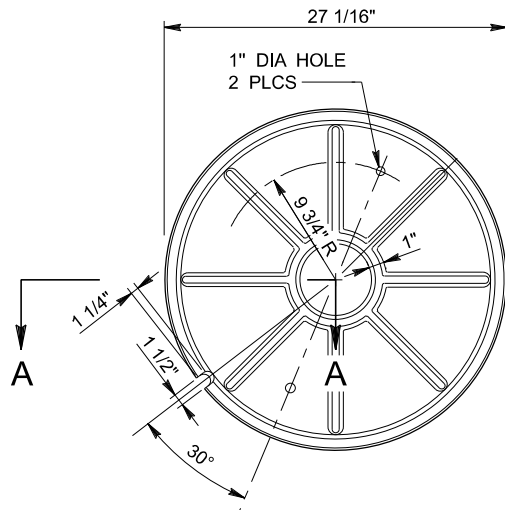

**PLAN OF COVER
BOTTOM VIEW**

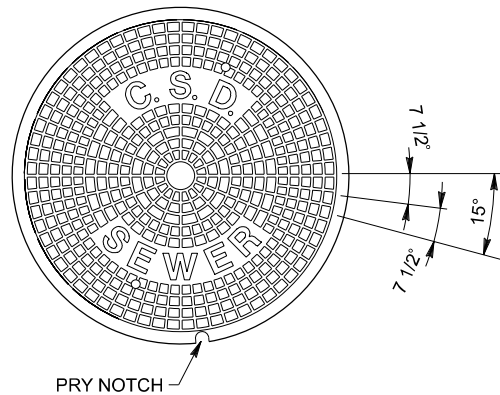

**PLAN OF COVER
TOP VIEW**

NOTE:
1. FOR NOTES SEE S-a-207.

COUNTY SANITATION DISTRICTS OF LOS ANGELES COUNTY
OFFICE OF CHIEF ENGINEER

ROBERT FERRANTE
CHIEF ENGINEER

**STANDARD 24" TRAFFIC MANHOLE
FRAME AND COVER**

STANDARD DRAWING
2021 EDITION
S - a - 2 2 8
SHEET 1 OF 1

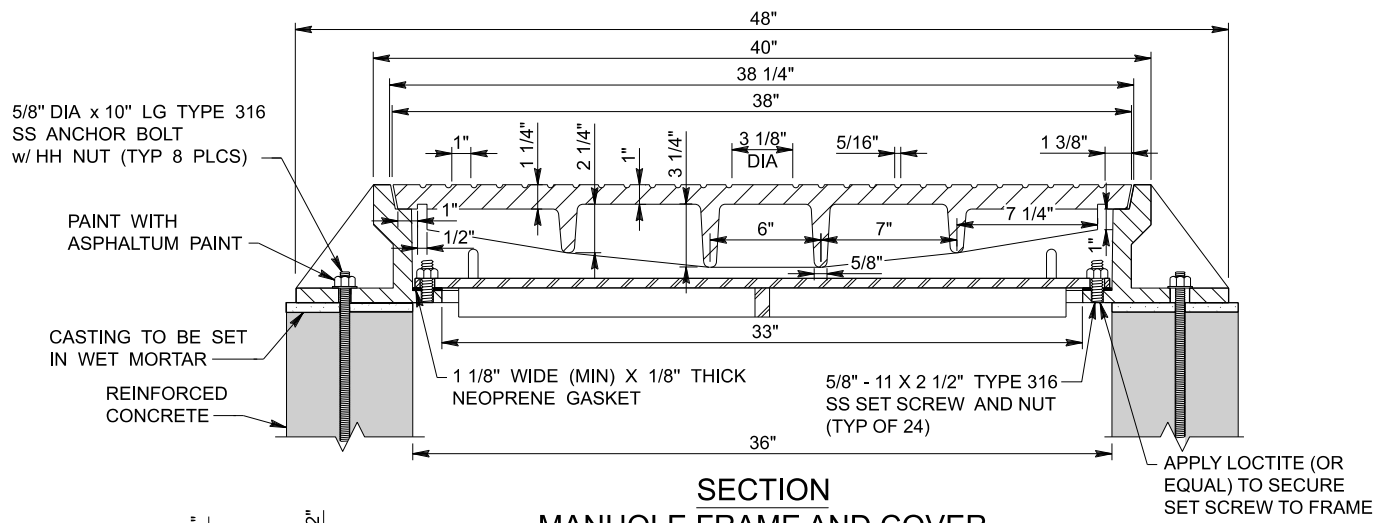

**SECTION
MANHOLE FRAME AND COVER**

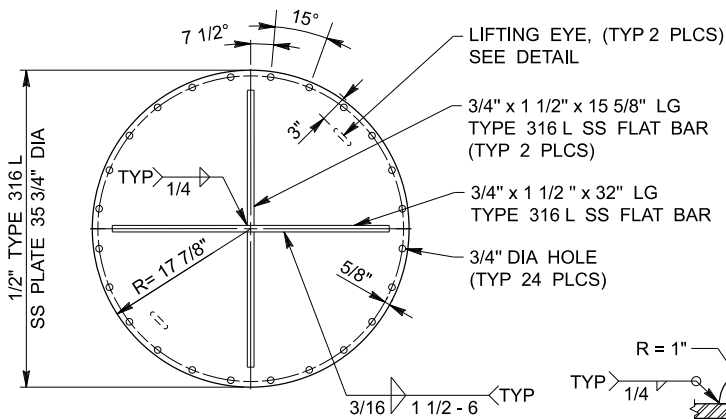
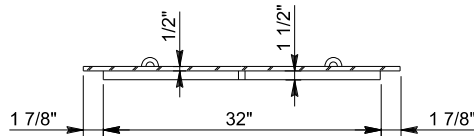

**PRESSURE PLATE
BOTTOM VIEW**

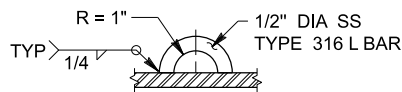

DETAIL- LIFTING EYE

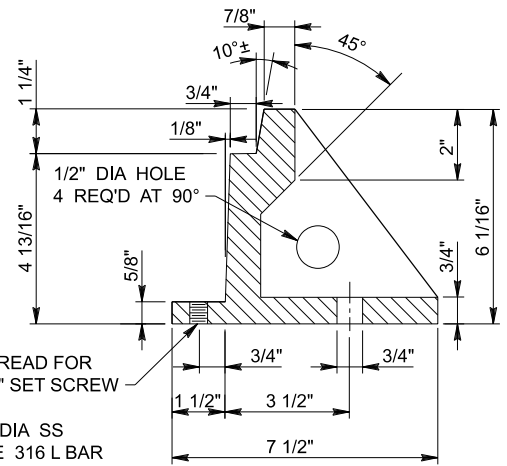

SECTION A-A

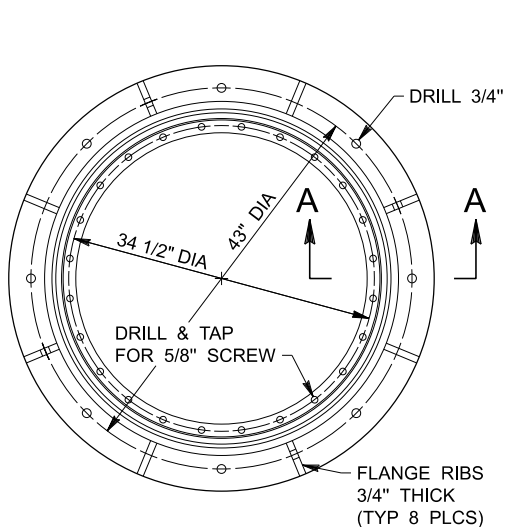

PLAN OF FRAME

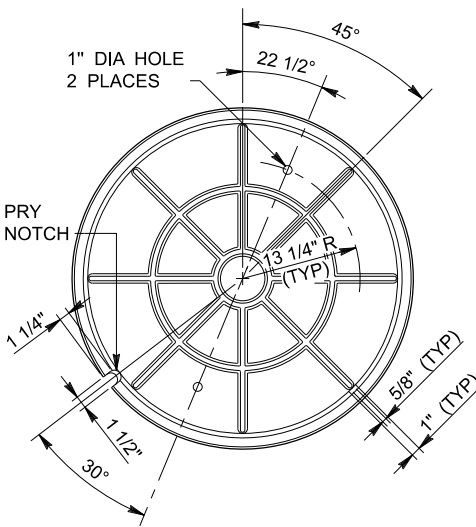

**PLAN OF COVER
BOTTOM VIEW**

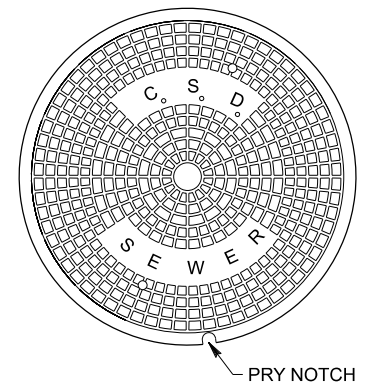

**PLAN OF COVER
TOP VIEW**

NOTE:

1. FOR NOTES SEE S-a-207.

COUNTY SANITATION DISTRICTS OF LOS ANGELES COUNTY
OFFICE OF CHIEF ENGINEER

ROBERT FERRANTE
CHIEF ENGINEER

**STANDARD 36" PRESSURE MANHOLE
FRAME AND COVER**

STANDARD DRAWING
2021 EDITION
S - a - 2 2 9
SHEET 1 OF 1

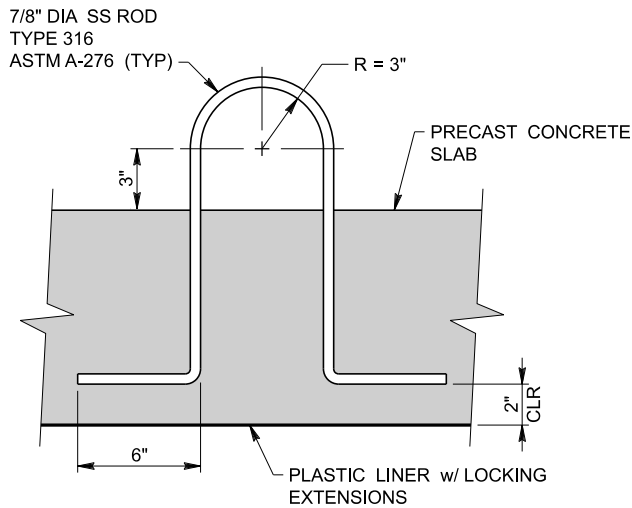

TYPE I LIFTING EYE

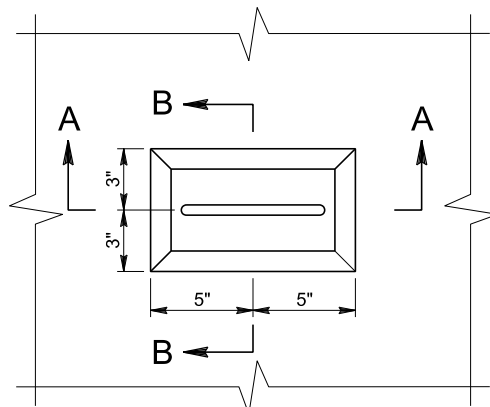

PLAN

COAT ALL RECESSED CONCRETE SURFACES WITH HENRY HE107, OR EQUAL, PRIOR TO FILLING RECESS WITH 2-SACK CEMENT SAND SLURRY.

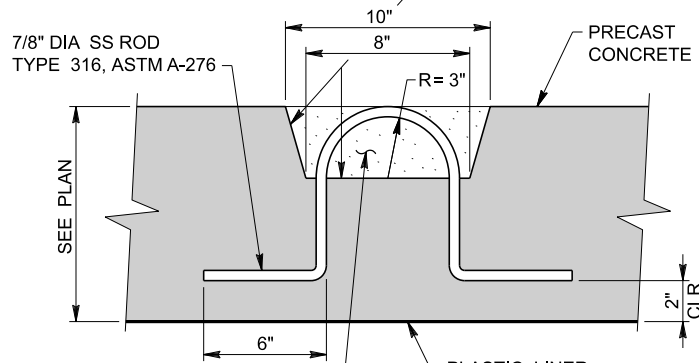

FILL RECESS WITH A 2-SACK CEMENT SAND SLURRY WITH 3/8" PEA GRAVEL. FINISH FLUSH WITH PRECAST CONCRETE SLAB.

SECTION A-A

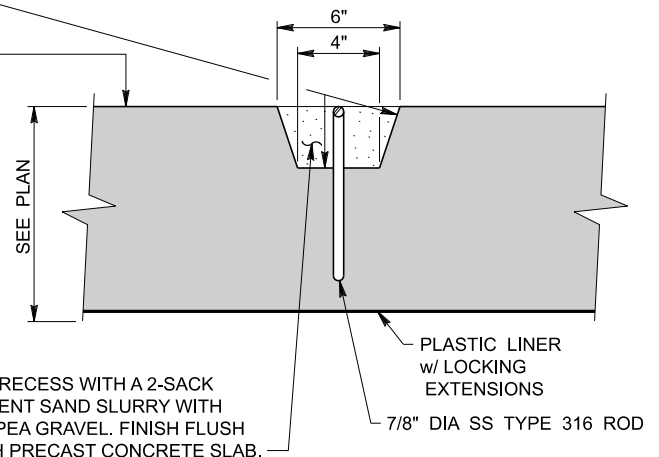

FILL RECESS WITH A 2-SACK CEMENT SAND SLURRY WITH 3/8" PEA GRAVEL. FINISH FLUSH WITH PRECAST CONCRETE SLAB.

SECTION B-B

TYPE II LIFTING EYE
(FOR COVER LESS THAN 12" THICK)

COUNTY SANITATION DISTRICTS OF LOS ANGELES COUNTY
OFFICE OF CHIEF ENGINEER

ROBERT FERRANTE
CHIEF ENGINEER

STANDARD LIFTING EYE

STANDARD DRAWING
2021 EDITION
S - a - 230
SHEET 1 OF 1

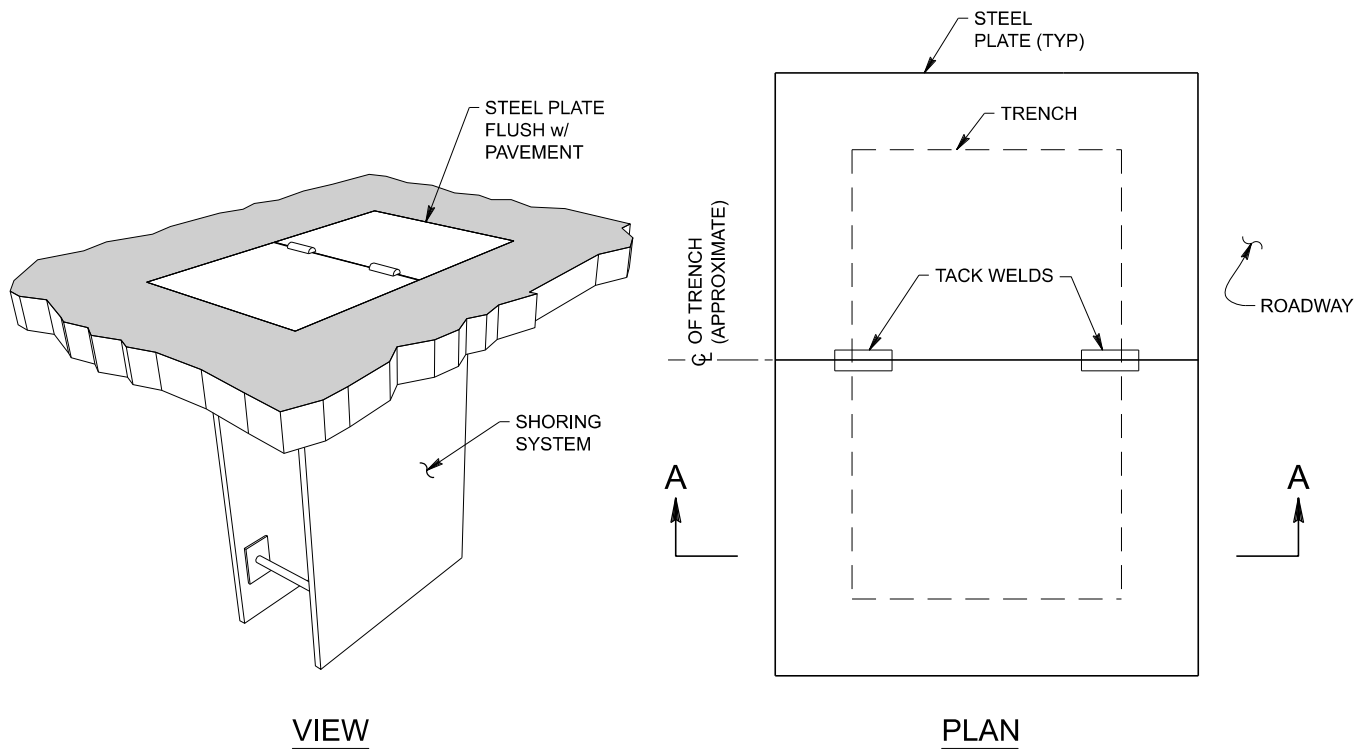

REPAIR PAVEMENT SECTION IN ACCORDANCE WITH PERMIT REQUIREMENTS AND STANDARDS OF LOCAL JURISDICTION.

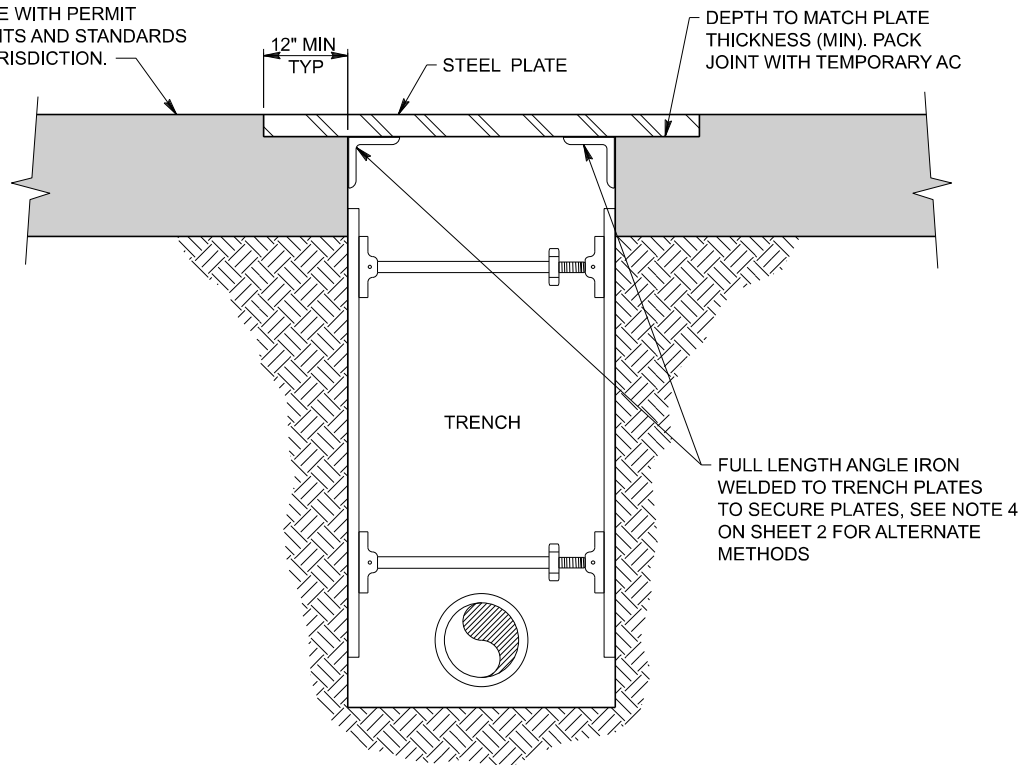

COUNTY SANITATION DISTRICTS OF LOS ANGELES COUNTY
OFFICE OF CHIEF ENGINEER

ROBERT FERRANTE
CHIEF ENGINEER

**STANDARD
RECESSED PLATE BRIDGING**

STANDARD DRAWING
2021 EDITION
S - a - 231
SHEET 1 OF 2

NOTES:

1. STEEL PLATE BRIDGING SHALL BE USED WHEN THE TRENCH WORK CANNOT BE COMPLETED WITHIN THE SAME WORKING DAY TO MAINTAIN ALL VEHICULAR, BICYCLE AND PEDESTRIAN TRAFFIC FLOW.
2. THE DETAILS AND NOTES SHOWN HEREIN SHALL BE USED FOR TRAFFIC AREAS UNLESS MORE STRINGENT REQUIREMENTS ARE PROVIDED BY THE LOCAL JURISDICTION (CITY, COUNTY, CALTRANS, ETC.) IN WHICH THE WORK IS TO BE PERFORMED. IN SUCH CASES, THE MORE STRINGENT REQUIREMENTS SHALL APPLY.
3. STEEL PLATES USED FOR BRIDGING SHALL EXTEND TWELVE (12) INCHES MINIMUM BEYOND THE EDGES OF THE TRENCH. THE SURFACE OF THE STEEL PLATES SHALL BE ROUGHENED, TAPED OR COATED TO PROVIDE A NON-SKID SURFACE FOR SAFETY OF THE TRAVELLING PUBLIC.
4. STEEL PLATE BRIDGING SHALL BE SECURED AGAINST MOVEMENT BY USING HOLDING DEVICES SUCH AS ADJUSTABLE CLEATS, ANGLES, WELDING OR OTHER DEVICES.
5. STEEL PLATE BRIDGING SHALL BE SNUG WITHIN THE RECESSED AREA AND INSTALLED TO OPERATE WITH MINIMUM NOISE.
6. THE TRENCH WALLS AND ADJACENT SOILS SHALL BE SUFFICIENTLY STABLE FOR THE USE OF THE PLATE SHOWN IN THE DETAIL.
7. THE TRENCH SHALL BE ADEQUATELY SHORED, IF NECESSARY, TO SUPPORT THE STEEL PLATE BRIDGING AND HS20-44 TRAFFIC LOADS.
8. THE PAVEMENT SHALL BE COLD PLANED TO A DEPTH EQUAL TO THE THICKNESS OF THE PLATE AND TO A WIDTH AND LENGTH EQUAL TO THE DIMENSIONS OF THE PLATE.
9. THE STEEL PLATES SHALL BE A MINIMUM OF 3'-6" IN WIDTH. MULTIPLE PLATES SHALL BE TACK WELDED (6" MINIMUM LENGTH AT MINIMUM TWO LOCATIONS AS SHOWN ON THE PLAN) AS NEEDED TO SECURE PLATES. ALL STEEL PLATES SHALL MEET ASTM A36.
10. THE MINIMUM STEEL PLATE BRIDGING THICKNESS, FOR A TRENCH WIDTH LESS THAN OR EQUAL TO 3'-0", SHALL BE ONE (1) INCH.
11. THE MINIMUM STEEL PLATE BRIDGING THICKNESS, FOR A TRENCH WIDTH GREATER THAN 3'-0" BUT LESS THAN OR EQUAL TO 4'-0", SHALL BE 1.25 INCHES.
12. FOR TRENCH AND EXCAVATION WIDTHS GREATER THAN 4'-0", A STRUCTURAL DESIGN OF THE STEEL PLATE BRIDGING SHALL BE SUBMITTED TO THE DISTRICTS FOR ACCEPTANCE PRIOR TO FABRICATION AND INSTALLATION. THE STRUCTURAL DESIGN SHALL BE STAMPED AND SIGNED BY A CIVIL OR STRUCTURAL ENGINEER CURRENTLY REGISTERED BY THE STATE OF CALIFORNIA.
13. STEEL PLATES USED FOR BRIDGING SHALL BE DESIGNED FOR A MINIMUM HS20-44 TRAFFIC LOAD.
14. ADVANCE WARNING SIGNS SHALL BE REQUIRED WHEN STEEL PLATES ARE USED IN THE TRAVELLED WAY. SIGNS SHALL BE 36" x 36" MUTCD W8-24. PLACEMENT AND SPACING OF SIGNS SHALL CONFORM TO THE LATEST EDITION OF THE CALIFORNIA MANUAL ON UNIFORM TRAFFIC CONTROL DEVICES (MUTCD), THE WORK AREA TRAFFIC CONTROL HANDBOOK (WATCH), AND/OR THE REQUIREMENTS OF THE LOCAL JURISDICTION.
15. THE CONTRACTOR SHALL BE RESPONSIBLE FOR MONITORING, MAINTENANCE, AND VERIFICATION OF PROPER ALIGNMENT OF THE STEEL PLATES AND SHORING FOR THE DURATION OF THEIR USE.

COUNTY SANITATION DISTRICTS OF LOS ANGELES COUNTY
OFFICE OF CHIEF ENGINEER

ROBERT FERRANTE
CHIEF ENGINEER

**STANDARD
RECESSED PLATE BRIDGING**

STANDARD DRAWING
2021 EDITION

S - a - 231

SHEET 2 OF 2

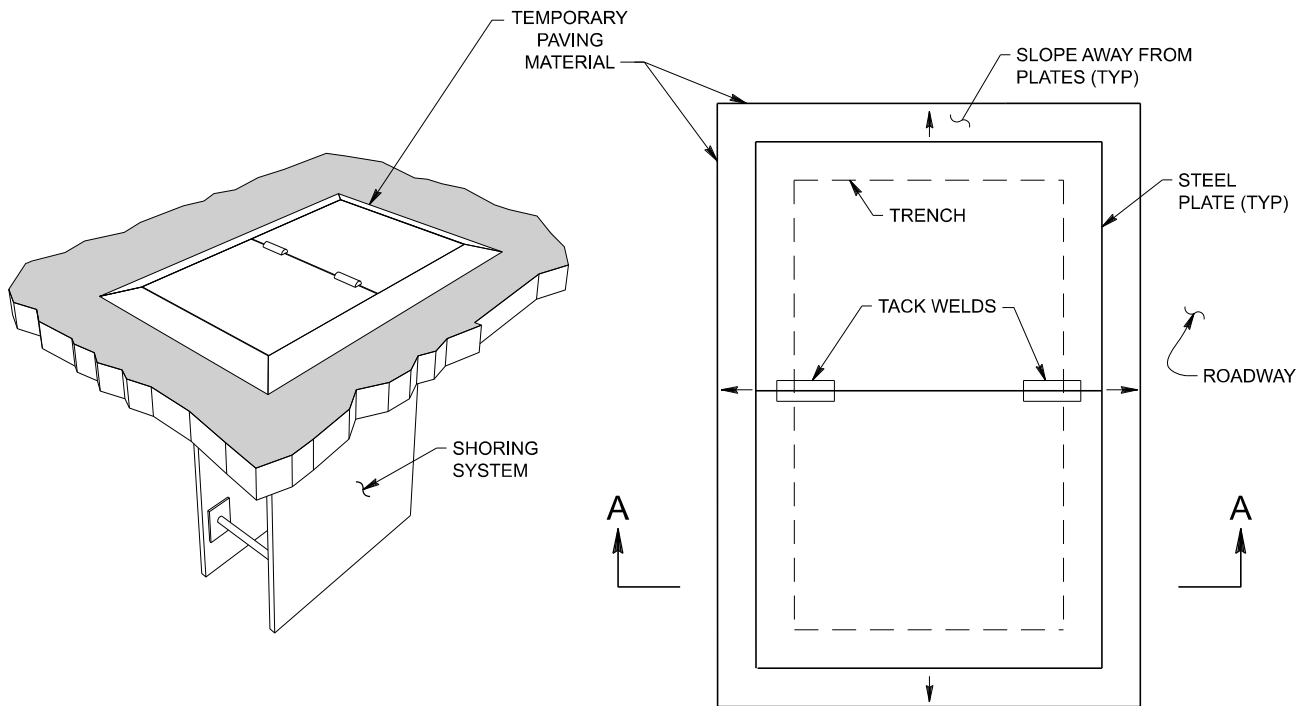

VIEW

PLAN

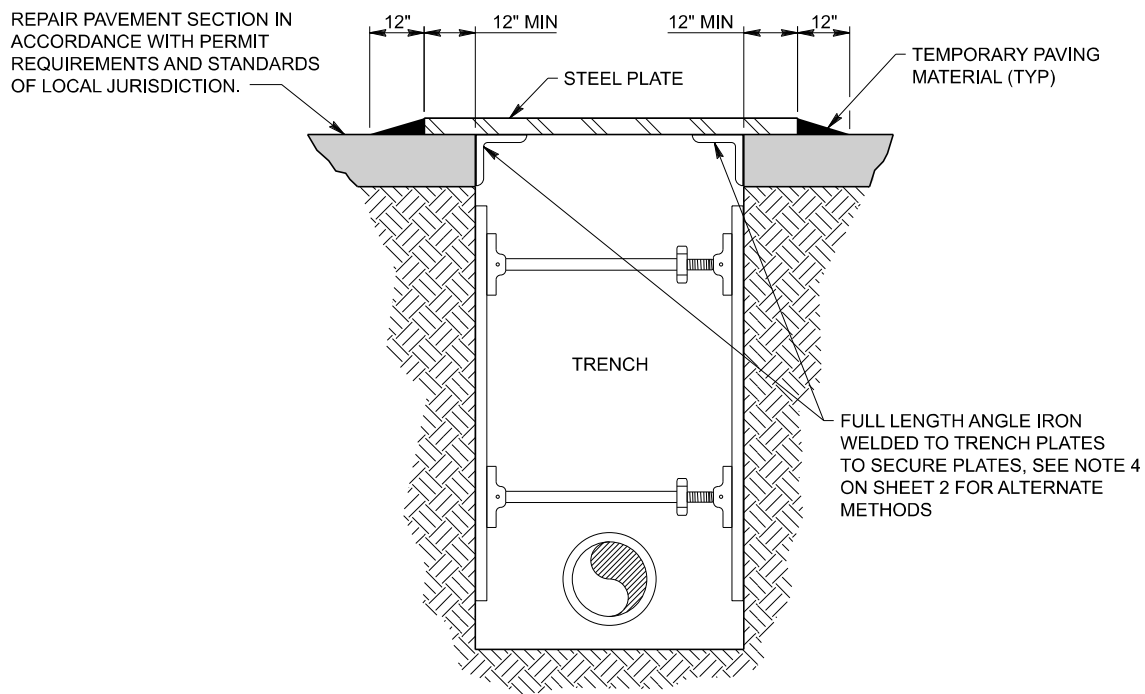

SECTION A-A

FOR TRAFFIC AREAS WITH SPEEDS OF 25 MPH OR LESS

COUNTY SANITATION DISTRICTS OF LOS ANGELES COUNTY
OFFICE OF CHIEF ENGINEER

ROBERT FERRANTE
CHIEF ENGINEER

**STANDARD
NON-RECESSED PLATE BRIDGING**

STANDARD DRAWING
2021 EDITION
S - a - 2 3 2
SHEET 1 OF 2

NOTES:

1. STEEL PLATE BRIDGING SHALL BE USED WHEN THE TRENCH WORK CANNOT BE COMPLETED WITHIN THE SAME WORKING DAY TO MAINTAIN ALL VEHICULAR, BICYCLE AND PEDESTRIAN TRAFFIC FLOW.
2. THE DETAILS AND NOTES SHOWN HEREIN SHALL ONLY BE USED FOR TRAFFIC AREAS WITH SPEEDS OF 25 MPH OR LESS UNLESS MORE STRINGENT REQUIREMENTS ARE PROVIDED BY THE LOCAL JURISDICTION (CITY, COUNTY, CALTRANS, ETC.) IN WHICH THE WORK IS TO BE PERFORMED. IN SUCH CASES, THE MORE STRINGENT REQUIREMENTS SHALL APPLY.
3. STEEL PLATES USED FOR BRIDGING SHALL EXTEND TWELVE (12) INCHES MINIMUM BEYOND THE EDGES OF THE TRENCH. THE SURFACE OF THE STEEL PLATES SHALL BE ROUGHENED, TAPED OR COATED TO PROVIDE A NON-SKID SURFACE FOR SAFETY OF THE TRAVELLING PUBLIC.
4. STEEL PLATE BRIDGING SHALL BE SECURED AGAINST MOVEMENT BY USING HOLDING DEVICES SUCH AS ADJUSTABLE CLEATS, ANGLES, WELDING OR OTHER DEVICES.
5. STEEL PLATE BRIDGING SHALL BE INSTALLED TO OPERATE WITH MINIMUM NOISE.
6. THE TRENCH WALLS AND ADJACENT SOILS SHALL BE SUFFICIENTLY STABLE FOR THE USE OF THE PLATE SHOWN IN THE DETAIL.
7. THE TRENCH SHALL BE ADEQUATELY SHORED, IF NECESSARY, TO SUPPORT THE STEEL PLATE BRIDGING AND HS20-44 TRAFFIC LOADS.
8. TEMPORARY PAVEMENT MATERIALS (SUCH AS FINE GRADE COLD ASPHALT CONCRETE) SHALL BE USED TO FORM RAMPS AT THE EDGES OF THE PLATES FOR A MINIMUM LENGTH OF TWELVE (12) INCHES BEYOND THE PLATE EDGES.
9. THE STEEL PLATES SHALL BE A MINIMUM OF 3'-6" IN WIDTH. MULTIPLE PLATES SHALL BE TACK WELDED (6" MINIMUM LENGTH AT MINIMUM TWO LOCATIONS AS SHOWN ON THE PLAN) AS NEEDED TO SECURE PLATES. ALL STEEL PLATES SHALL MEET ASTM A36.
10. THE MINIMUM STEEL PLATE BRIDGING THICKNESS, FOR A TRENCH WIDTH LESS THAN OR EQUAL TO 3'-0", SHALL BE ONE (1) INCH.
11. THE MINIMUM STEEL PLATE BRIDGING THICKNESS, FOR A TRENCH WIDTH GREATER THAN 3'-0" BUT LESS THAN OR EQUAL TO 4'-0", SHALL BE 1.25 INCHES.
12. FOR TRENCH AND EXCAVATION WIDTHS GREATER THAN 4'-0", A STRUCTURAL DESIGN OF THE STEEL PLATE BRIDGING SHALL BE SUBMITTED TO THE DISTRICTS FOR ACCEPTANCE PRIOR TO FABRICATION AND INSTALLATION. THE STRUCTURAL DESIGN SHALL BE STAMPED AND SIGNED BY A CIVIL OR STRUCTURAL ENGINEER CURRENTLY REGISTERED BY THE STATE OF CALIFORNIA.
13. STEEL PLATES USED FOR BRIDGING SHALL BE DESIGNED FOR A MINIMUM HS20-44 TRAFFIC LOAD.
14. ADVANCE WARNING SIGNS SHALL BE REQUIRED WHEN STEEL PLATES ARE USED IN THE TRAVELLED WAY. SIGNS SHALL BE 36" x 36" MUTCD W8-24. PLACEMENT AND SPACING OF SIGNS SHALL CONFORM TO THE LATEST EDITION OF THE CALIFORNIA MANUAL ON UNIFORM TRAFFIC CONTROL DEVICES (MUTCD), THE WORK AREA TRAFFIC CONTROL HANDBOOK (WATCH), AND/OR THE REQUIREMENTS OF THE LOCAL JURISDICTION.
15. THE CONTRACTOR SHALL BE RESPONSIBLE FOR MONITORING, MAINTENANCE, AND VERIFICATION OF PROPER ALIGNMENT OF THE STEEL PLATES AND SHORING FOR THE DURATION OF THEIR USE.

C O U N T Y S A N I T A T I O N D I S T R I C T S O F L O S A N G E L E S C O U N T Y
O F F I C E O F C H I E F E N G I N E E R

ROBERT FERRANTE
CHIEF ENGINEER

**STANDARD
NON-RECESSED PLATE BRIDGING**

STANDARD DRAWING
2021 EDITION
S - a - 2 3 2
SHEET 2 OF 2

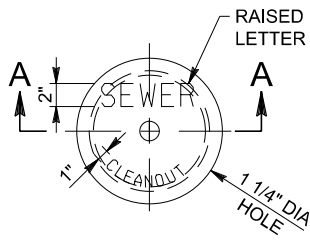

ACCESS COVER

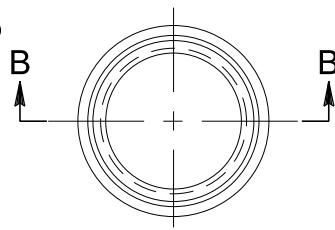

ACCESS FRAME

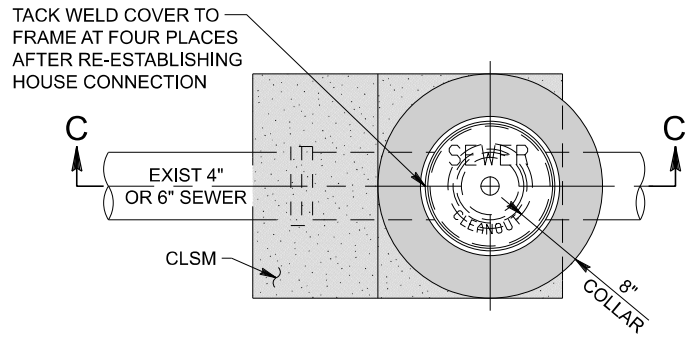

PLAN

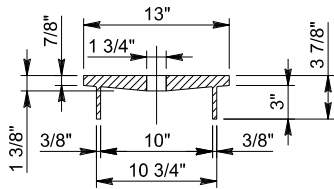

SECTION A-A

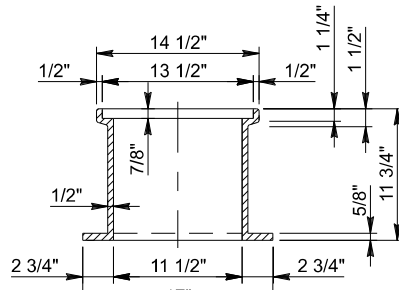

SECTION B-B

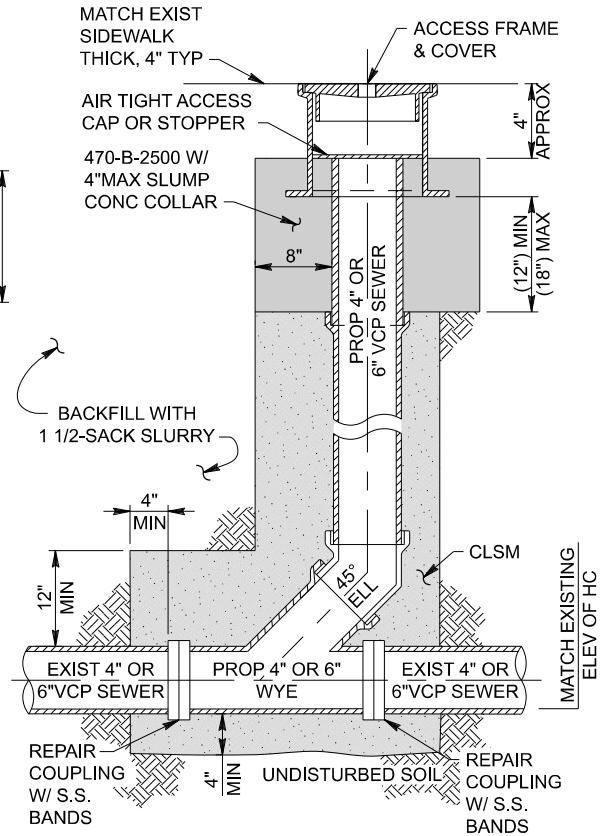

SECTION C-C

NOTES:

1. UNLESS OTHERWISE SPECIFIED OR REQUIRED BY THE CITY OR OTHER LOCAL PERMITTING AGENCY, CLEANOUT SHALL BE CONSTRUCTED IN ACCORDANCE WITH THIS DETAIL.
2. DETERMINE LOCATION AND DEPTH OF HOUSE CONNECTION AND MATCH EXISTING PIPE ELEVATION WITH PROPOSED CLEANOUT AS SHOWN.
3. UNLESS OTHERWISE SPECIFIED, PIPE AND FITTINGS SHALL BE OF THE SAME DIAMETER AND MATERIALS AS THE EXISTING SEWER.
4. PIPE AND FITTINGS SHALL BE BEDDED WITH CLSM PER 201-6. JOIN AND ALIGN PIPE AND FITTINGS BEFORE PLACING CLSM. MAINTAIN ALIGNMENT WHILE PLACING AND ALLOWING CLSM TO SET.
5. THE ACCESS FRAME AND COVER SHALL BE CAST IRON, ALHAMBRA FOUNDRY A-1241 OR EQUAL. THE FINGER HOLE MAY BE DRILLED OR BLOCKED OUT PRIOR TO CASTING. IT SHALL NOT BE PUNCHED OUT.
6. PLACE EITHER CIRCULAR OR SQUARE PIPE WALL SUPPORTS. THE CONCRETE COLLAR SHALL BE ROUND.

CLEANOUT DETAILS
NOT TO SCALE