

(4) 1/2-13 X 2"  
HEX SS CAP SCREWS  
W./ WASHERS

(2) DROP HANDLES  
(SEE DETAIL)

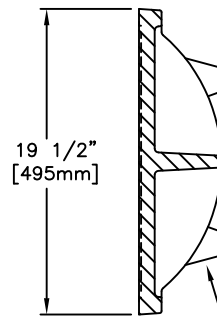

COVER SECTION

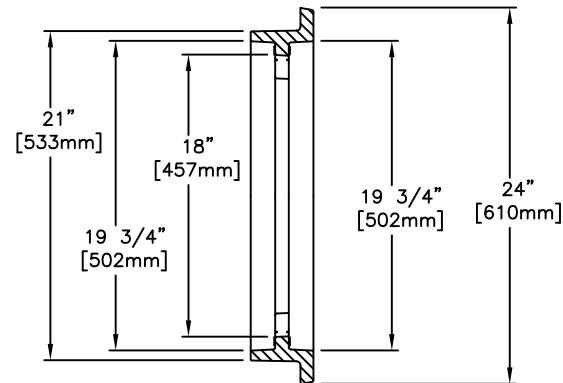

STACKING LUGS  
(4) PLACES

FRAME SECTION

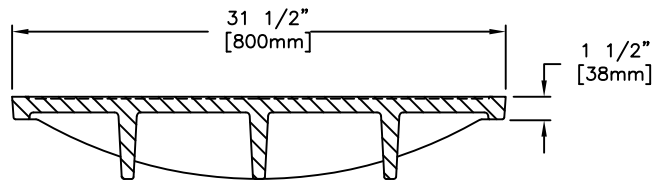

COVER SECTION

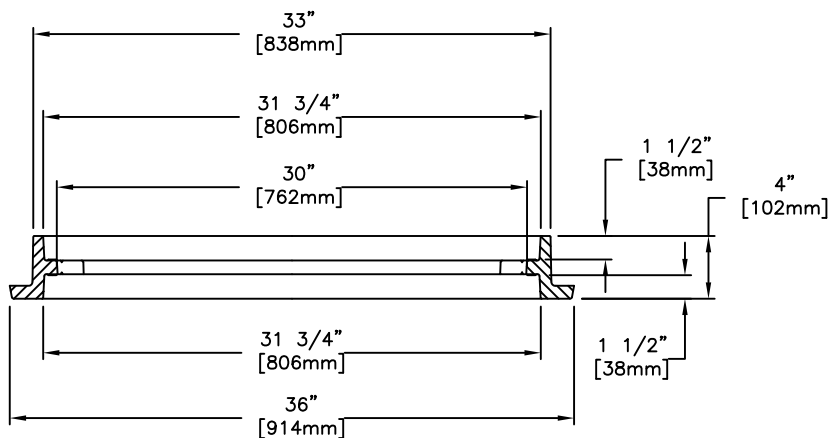

FRAME SECTION

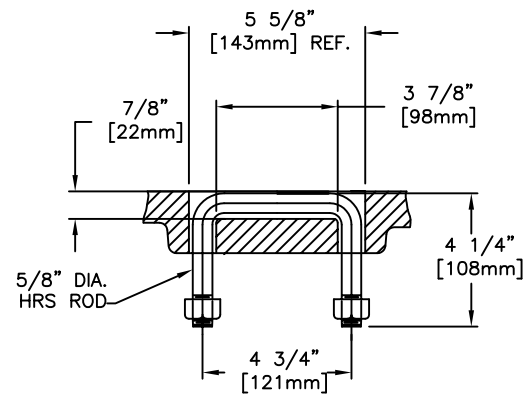

HANDLE DETAIL

EAST JORDAN  
IRON WORKS, INC.  
P.O. BOX 439  
EAST JORDAN, MI. 49727  
1-800-874-4100  
FAX 231-536-4458

DRAWN DEW	DATE 11/18/01
--------------	------------------

APPROVED	DATE
----------	------

## BOTTOM FLANGE MANHOLE ASSEMBLY

PRODUCT NO.

**00808302**

CATALOG NO.

**8083APT DI  
8083ZPT**

REF. PRODUCT DRAWING

**808323  
808313**

EST. WT.

COVER: 215 LBS 98kg  
FRAME: 130 LBS 59kg  
UNIT: 345 LBS 156kg

OPEN AREA

N/A

MAT'L SPEC.

COVER - DUCTILE IRON  
ASTM A536

FRAME - GRAY IRON  
ASTM A48 CL35B

LOAD RATING

EXTRA HEAVY DUTY  
(PROOF LOAD TESTED  
TO 200,000 LBS.)