

8197 Assembly

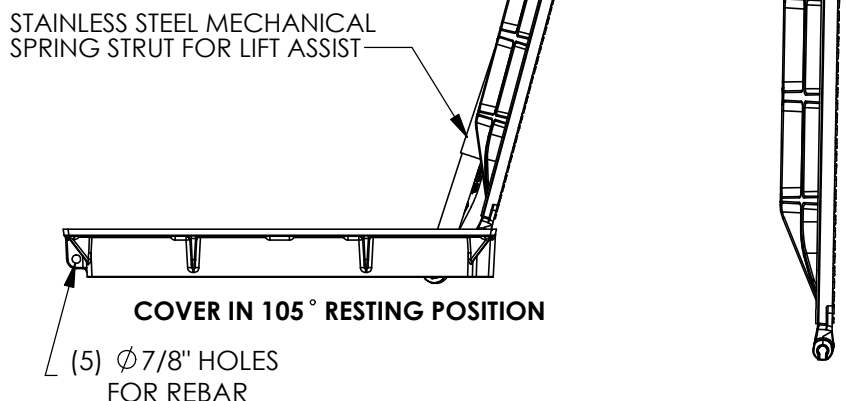
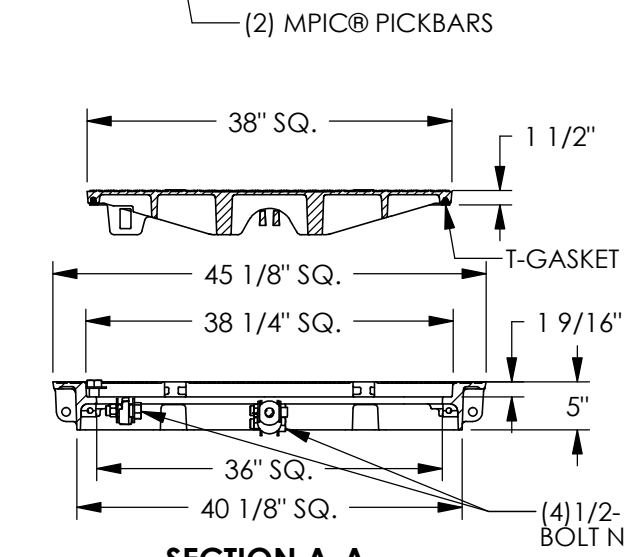
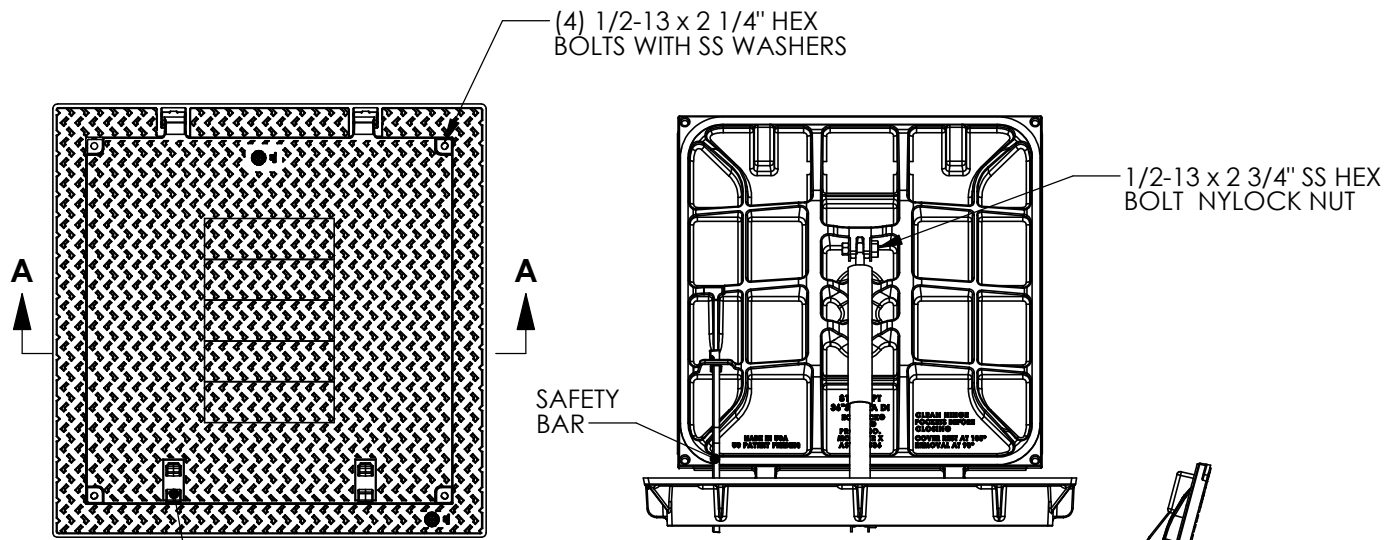

Product Number
00819761B01

Design Features

- Materials
 - Hatch Frame
Ductile Iron (70-50-05)
 - Hatch Cover
Ductile Iron (80-55-06)

- Design Load
Airport Extra Heavy Duty (Proof Load Tested to 200,000lbs.)
- Open Area
n/a
- Coating
Undipped
- √ Designates Machined Surface
- Slip Resistant Surface with the LLLL® registered trademark

Certification

- ASTM A536
-
- Country of Origin: USA

Major Components

00819711
00819761

Drawing Revision

4/24/2010 Designer: DEF
2/6/2012 Revised By: DEF

Disclaimer

Weights (lbs/kg), dimensions (inches/mm) and drawings provided for your guidance. We reserve the right to modify specifications without prior notice.

CONFIDENTIAL: This drawing is the property of EJ Group, Inc. and embodies confidential information, registered marks, patents, trade secret information, and/or know-how that is the property of EJ Group, Inc. Copyright © 2011 EJ Group, Inc. All rights reserved.

Contact

800.626.4653
ejco.com