

800-626-4653  
www.ejiw.com  
MADE IN USA

PRODUCT NUMBER  
**00184520A01**

CATALOG NUMBER  
**1843Z2**  
**1845ADI**

**MANHOLE  
ASSEMBLY**

EXTRA HEAVY DUTY  
(PROOF LOAD TESTED  
TO 200,000 LBS.)

COATING  
**UNDIPPED**

ESTIMATED WEIGHT  
RING: 380LBS  
COVER: 533LBS  
UNIT: 913LBS

MATERIAL SPECIFICATION  
COVER - DUCTILE IRON  
ASTM A536  
FRAME - GRAY IRON  
ASTM A48 CL35B

OPEN AREA  
N/A

√ DESIGNATES MACHINED  
SURFACE

DRAWN GAD DATE 05/12/08

LAST REVISED DATE

REFERENCE INFORMATION

00184520  
00184314

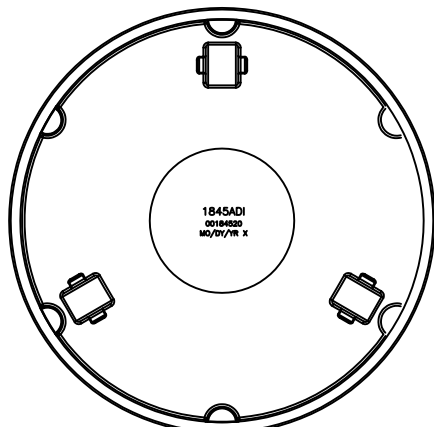

COVER BACK

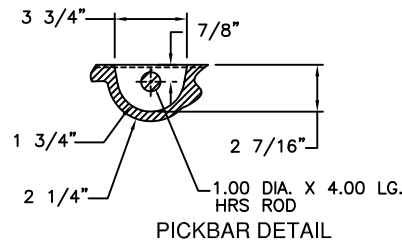

PICKBAR DETAIL

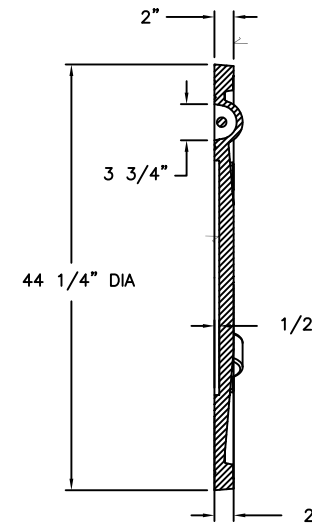

COVER SECTION

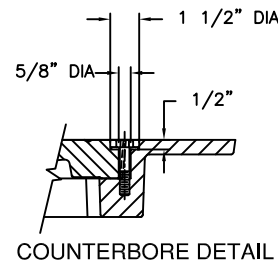

COUNTERBORE DETAIL

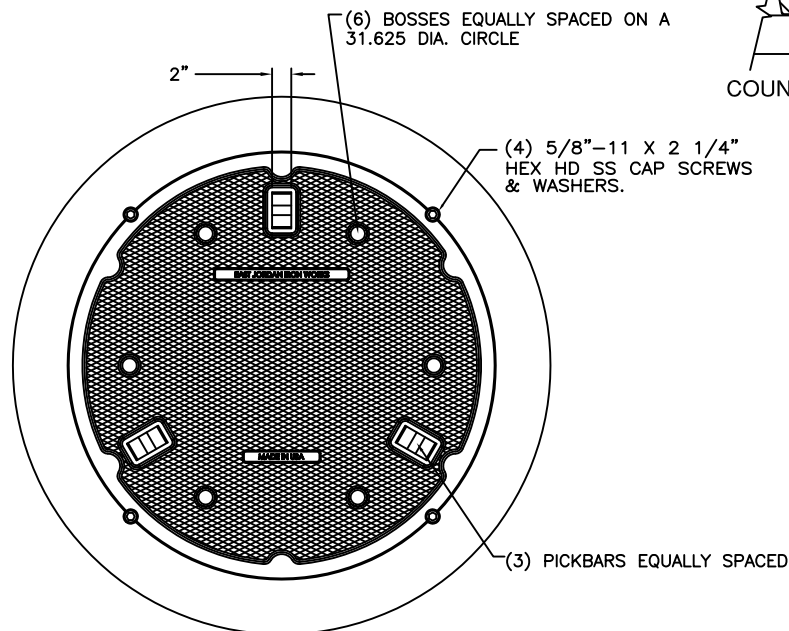

RING & COVER TOP VIEW

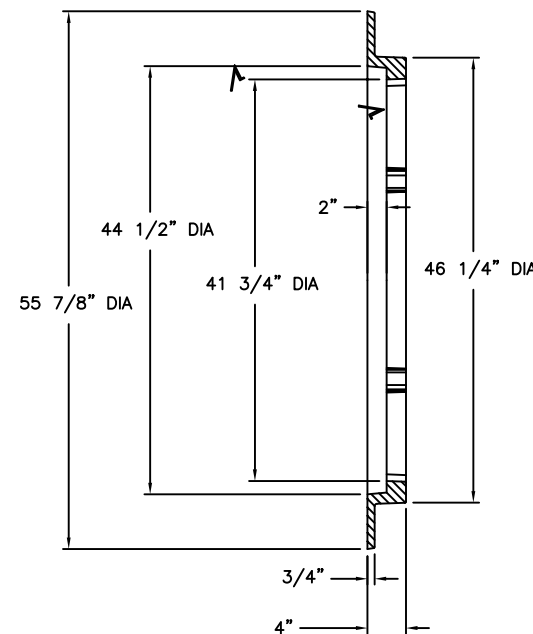

RING SECTION

NOTE: COVER IS MADE FROM THE 00184540.  
SHIPPED BACK FROM SEATTLE!