



LBIW Inc.

2020 WEST 14TH STREET
LONG BEACH, CA. 90813
Tel No. : (562) 432.5451
Fax No. : (562) 435.5929

www.lbiw.com

PRODUCT NUMBER
APWA 305

STEEL FRAME
2 GRATES

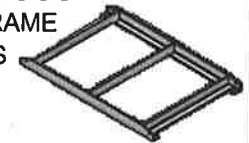

LOAD RATING

SPECIFICATIONS

MATERIAL : ASTM A36
COATING : ASTM A123
(GALVANIZING)

MADE IN USA

EST. WEIGHT

LBS

STANDARD PLAN REFERENCE

*APWA 311-3
*APWA 305-3

DRAWN

EB

REVISED

DATE

04-05-17

DATE

REFERENCE INFORMATION

LBIW CATALOG
SECTION 07

REVISED 2016 EB

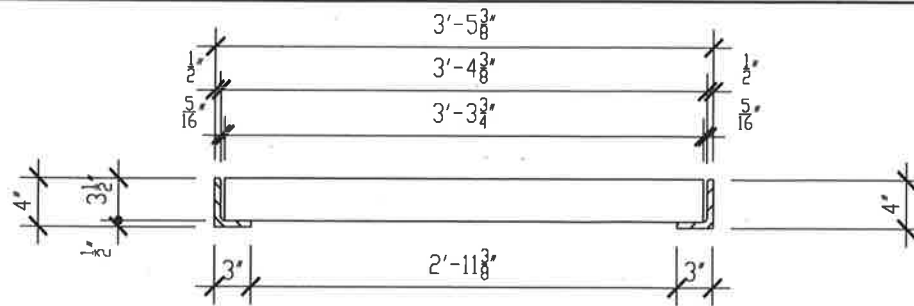

SECTION B-B

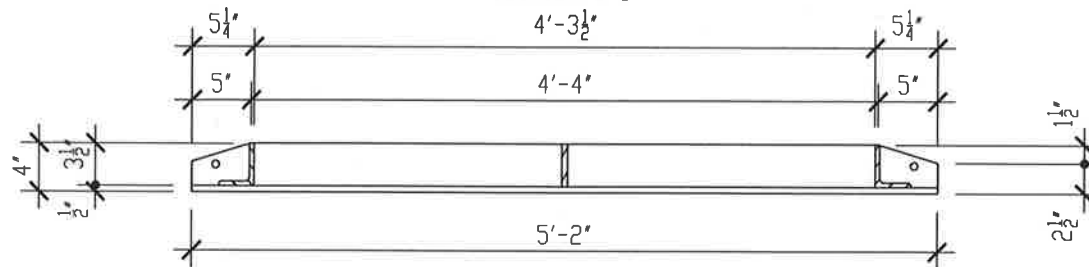

SECTION A-A

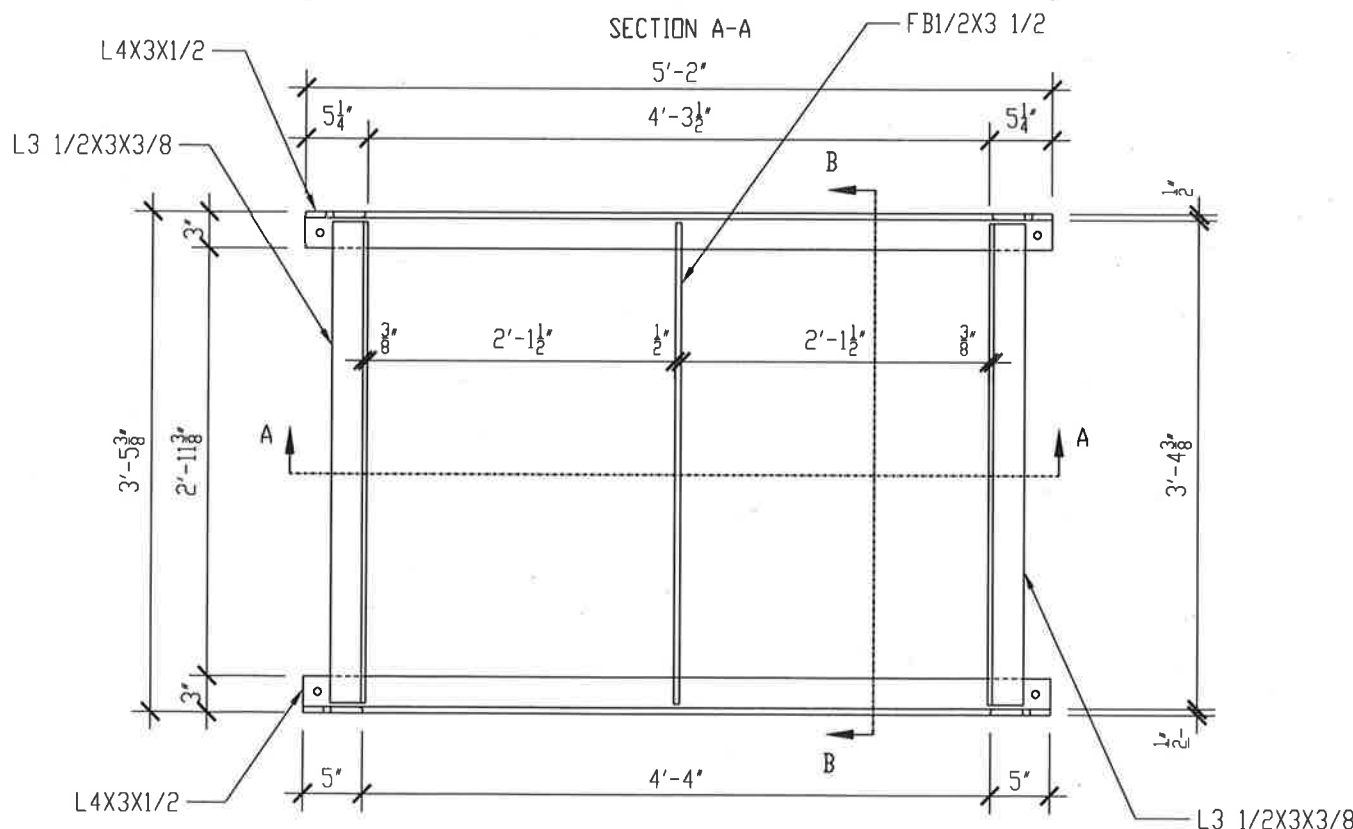

APWA 305 2 GRATES

L3 1/2X3X3/8