

PLAN OF COVER
TOP VIEW

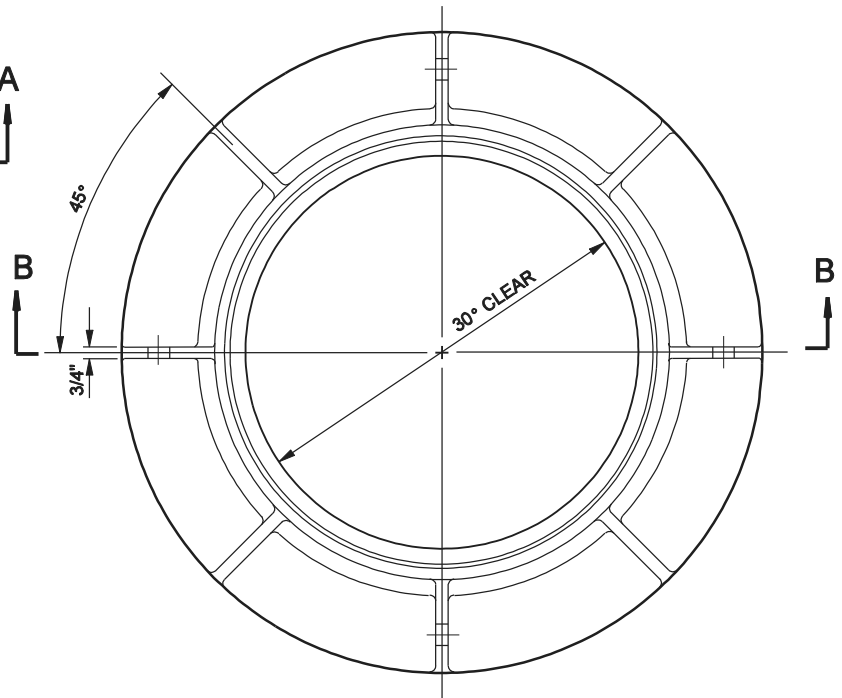

PLAN OF FRAME

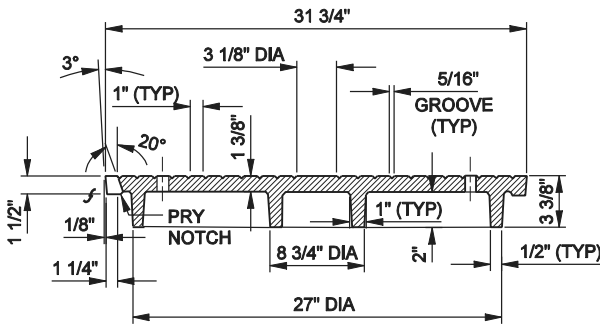

SECTION A-A

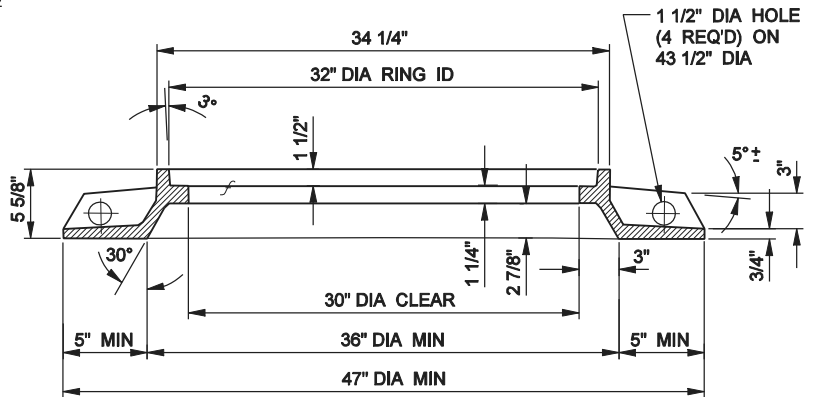

SECTION B-B

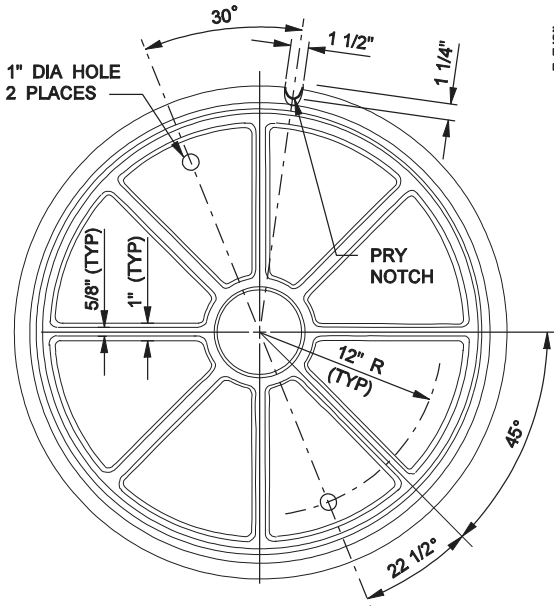

PLAN OF COVER
BOTTOM VIEW

NOTES:

1. CAST IRON USED SHALL CONFORM WITH ASTM A-48 CLASS 35B.
2. FRAME AND COVER SHALL BE COATED WITH ASPHALTUM OR BITUMINOUS PAINT AFTER TESTING AND INSPECTION.
3. FRAME AND COVER SHALL BE TESTED FOR ACCURATE FIT PRIOR TO DELIVERY AND SHALL BE MARKED IN SETS.
4. ALL CASTINGS SHALL COMPLY WITH SECTION 206-3 OF THE STANDARD SPECIFICATIONS.

COUNTY SANITATION DISTRICTS OF LOS ANGELES COUNTY
OFFICE OF CHIEF ENGINEER

STEPHEN R. MAGUIN
CHIEF ENGINEER

**STANDARD 36" MANHOLE FRAME
WITH 30" COVER**

STANDARD DRAWING
2006 EDITION
S - a - 2 2 6
SHEET 1 OF 1