

SECTION

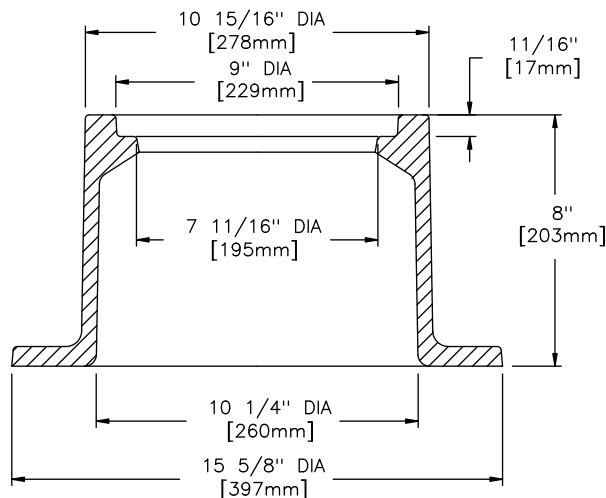

FRAME SECTION

EJIW EAST JORDAN
IRON WORKS EST. 1883

800-626-4653

www.ejiw.com

MADE IN USA

PRODUCT NUMBER

00157401

CATALOG NUMBER

**1574Z
1574A**

**MANHOLE
ASSEMBLY**

LOAD RATING

HEAVY DUTY

COATING

DIPPED

ESTIMATED WEIGHT

FRAME: 62 LBS 28kg

COVER: 17 LBS 8kg

UNIT: 79 LBS 36kg

MATERIAL SPECIFICATION

COVER - GRAY IRON

ASTM A48 CL35B

FRAME - GRAY IRON

ASTM A48 CL35B

OPEN AREA

N/A

✓ DESIGNATES MACHINED SURFACE

DRAWN

DEW

DATE

11/16/06

LAST REVISED

DATE

REFERENCE INFORMATION

157410

157421