

(4) 1/2"- 13 X 2 1/4" HEX HD S.S. CAP SCREWS W/SS LOCK AND PLAIN WASHERS

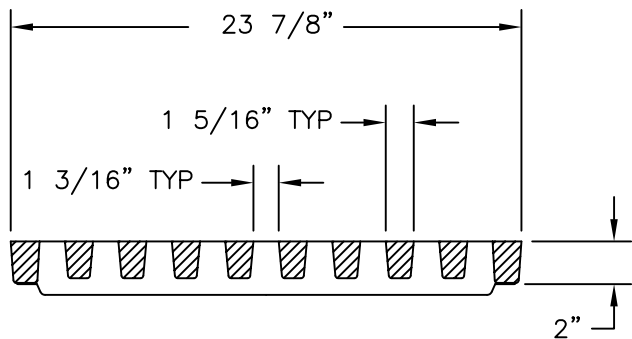

SECTION

CAUTION: DO NOT DISASSEMBLE BOLTED GRATES AND CHECK FRAME WIDTH INSIDE BEFORE SETTING SECTIONS IN CONCRETE.

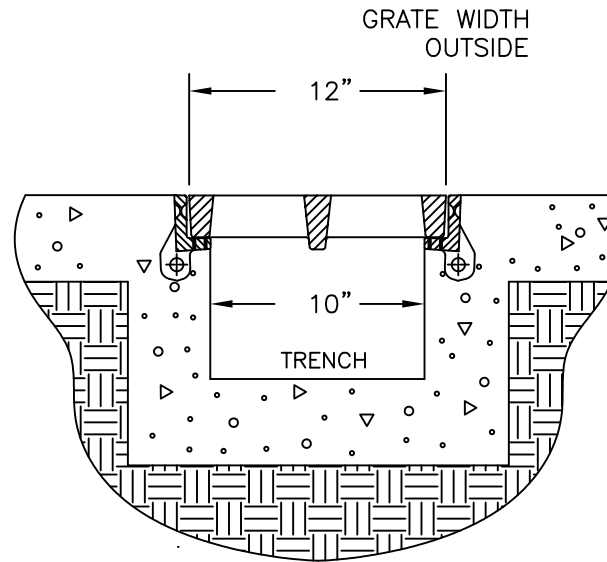

SECTION

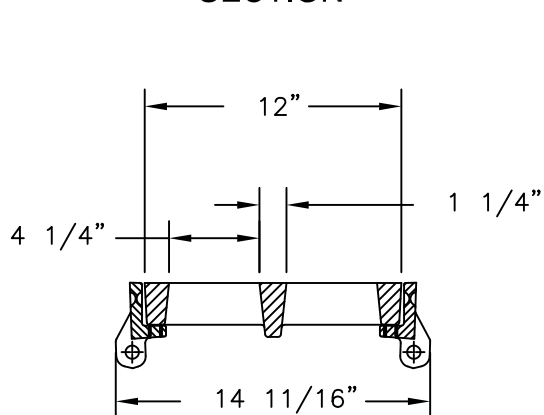

SECTION

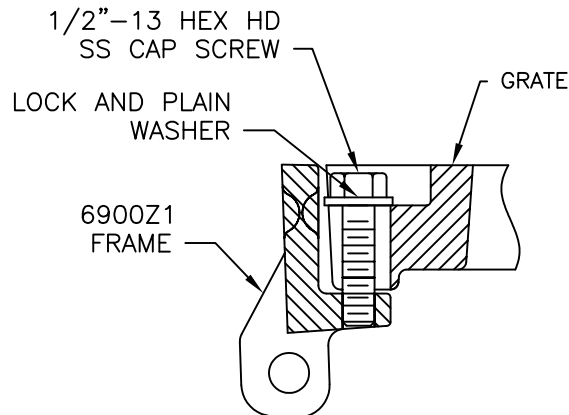

BOLT DETAIL

EJIW EAST JORDAN
IRON WORKS EST.1883

800-626-4653
www.ejiw.com
MADE IN USA

PRODUCT NUMBER

00690306

CATALOG NUMBER

6903M2DI
6900Z1

TRENCH GRATE ASSEMBLY

EXTRA HEAVY DUTY
(PROOF LOAD TESTED TO 200,000 LBS.)

COATING

UNDIPPED

MATERIAL SPECIFICATION

GRATE- DUCTILE IRON
ASTM A536

FRAME - GRAY IRON
ASTM A48 CL35B

OPEN AREA
N/A

√ DESIGNATES MACHINED SURFACE

DRAWN
GAD

DATE
06/05/08

LAST REVISED
SMM

DATE
02/02/11

REFERENCE INFORMATION

00690023
00690346