

**PLATEN COVER  
TOP VIEW**

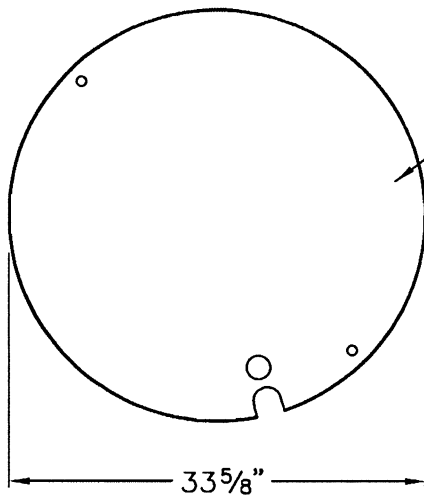

**PLATEN COVER  
BOTTOM VIEW**

COUNTERBORE  $1\frac{1}{8}$ "  
x  $\frac{5}{16}$ " DEEP AND  
DRILL  $\frac{7}{16}$ " DIAMETER  
HOLE ON  $31\frac{1}{8}$ " B.C.  
(2 PLACES)

$1\frac{1}{2}$ " x  $1\frac{1}{2}$ " OPEN  
EDGE PICKHOLE WITH  
1" DIAMETER HOLE 3"  
FROM EDGE OF COVER

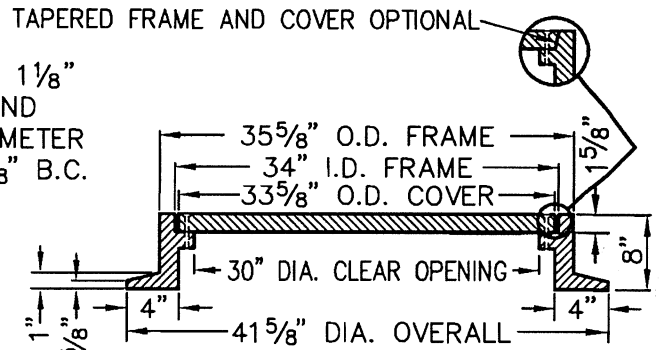

**SECTION A-A**

DRILL AND TAP FRAME  
FOR  $\frac{3}{8}$ "-16"x $1\frac{1}{2}$ "  
SOCKET SET SCREW  
BOLTS ON  $31\frac{1}{8}$ " B.C.  
(2 PLACES)

MACHINED  
SURFACE

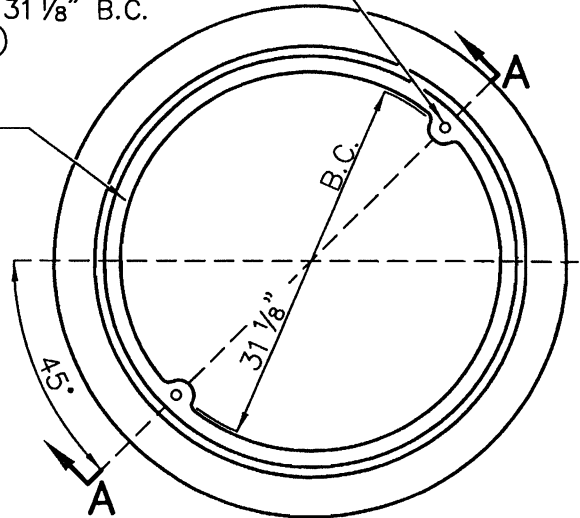

**PLAN OF FRAME**

**NOTES:**

1. MANHOLE FRAME AND COVER TO BE MANUFACTURED FROM CLASS 35 CAST IRON PER ASTM A-48.
2. FRAME AND COVER SHALL BE CAPABLE OF SUPPORTING H-20 WHEEL LOADING.
3. COVER SHALL HAVE CAST INTO TOP IN 1" HIGH MINIMUM BLOCK LETTERS "VICTORVILLE" OR "CITY OF VICTORVILLE" AND "SEWER". MANUFACTURER'S NAME OR INSIGNIA SHALL BE CAST INTO BOTH FRAME AND COVER.
4. MACHINE MATING SURFACES OF FRAME AND COVER TO PROVIDE UNIFORM EDGE SUPPORT FOR COVER.
5. PAINT FRAME AND COVER WITH BLACK BITUMINOUS PAINT.
6. APPROVED SUPPLIERS: ALHAMBRA FOUNDRY #1254, NEENAH FOUNDRY #R-1593 AND SOUTH BAY FOUNDRY #SBF1253B.

APPROVED BY		<b>SANITARY SEWER</b>	<b>SS-02A</b>
CITY ENGINEER			
DATE	INITIALS	<b>30" MANHOLE FRAME AND COVER</b>	SHEET 1 OF 1
12/1/08	J. McGLADE		