

# 6904M2DI 6900Z4 ASSEMBLY

## PRODUCT NUMBER

00690457B01

## DESIGN FEATURES

### MATERIALS

GRATE - DUCTILE IRON  
ASTM A536

FRAME - GRAY IRON  
ASTM A48 CL35B

### DESIGN LOAD

EXTRA HEAVY DUTY  
(PROOF LOAD TESTED  
TO 200,000 LBS.)

COATING  
UNDIPPED

OPEN AREA  
98 SQ. INCHES

√ DESIGNATES MACHINE SURFACE

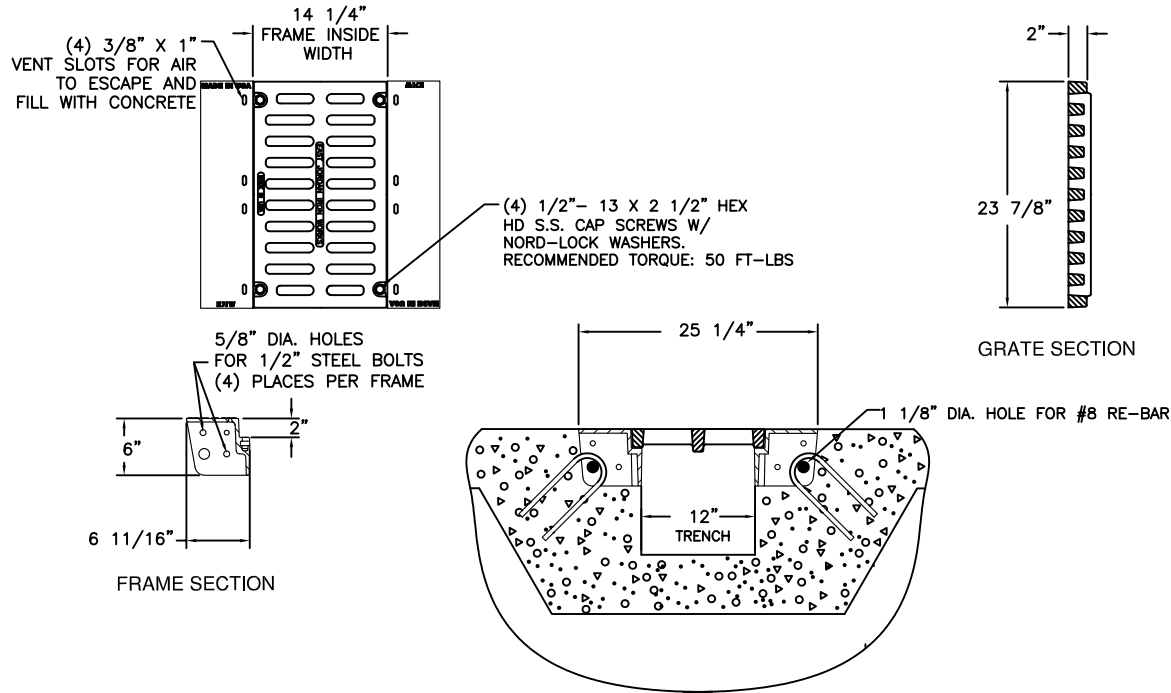

**CAUTION:**  
DO NOT DISASSEMBLE BOLTED GRATES.  
CHECK FRAME WIDTH INSIDE BEFORE  
SETTING SECTIONS IN CONCRETE.

**NOTE:** PALLETIZE WITH WOOD BLOCKING SO GRATES ARE SUPPORTED AND STAY FLUSH AND PARALLEL WITH TOP SURFACES OF SIDE FRAMES. ENDS OF SIDE FRAMES MUST BE PARALLEL AND IN-LINE. GRATE MUST NOT EXTEND PAST ENDS OF SIDE FRAMES. GRATE MUST BE FLUSH OR BACK SLIGHTLY. CHECK BOTH ENDS OF ASSEMBLY WITH STRAIGHT EDGE. DOUBLE BAND PALLET, BOTH DIRECTIONS WITH HEAVY STEEL BANDING. DO NOT SHRINK WRAP.

1/2" STEEL BOLTS SHOULD BE FINGER  
TIGHT TO KEEP FRAMES TRUE  
(SUPPLIED BY OTHERS)

#8 RE-BAR  
(SUPPLIED BY OTHERS)  
#4 RE-BAR  
(SUPPLIED BY OTHERS)

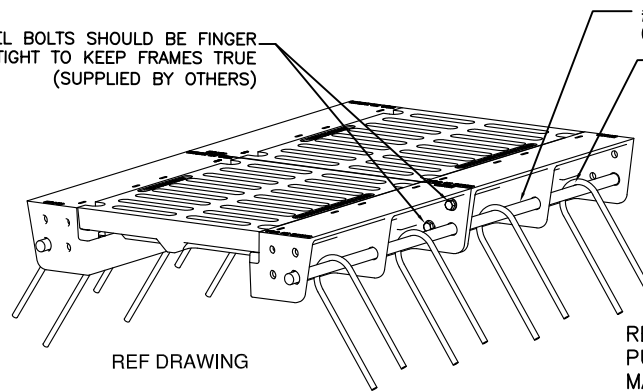

REF DRAWING

REF DWG FOR ASSEMBLY  
PURPOSES ONLY  
MAY NOT REPRESENT  
ACTUAL GRATE LISTED.

## REFERENCE INFORMATION

00690011  
00690457

## DRAWING DETAILS

ORIGINAL DRAWING: JIJ 02/24/10

REVISED BY: SMM 07/06/11

Corporate  
Headquarters  
301 Spring Street  
PO Box 439  
East Jordan, MI  
49727-0439  
800.874.4100



Call Today for  
More Information

800.626.4653

**EJIW EAST JORDAN**  
IRON WORKS EST 1883  
WE COVER YOUR INFRASTRUCTURE

www.ejiw.com  
MADE IN THE USA

- Weights (lbs./kg.) dimensions (inches/mm.), and drawings provided for your guidance.
- We reserve the right to modify specifications without prior notice.
- Uncontrolled distribution.

CONFIDENTIAL: This drawing is the property of East Jordan Iron works, Inc., and embodies confidential information, registered marks, trade secret information, and/or know how that is the property of East Jordan Iron Works, Inc. ©Copyright 2009 East Jordan Iron Works, Inc.