

SECTION A-A

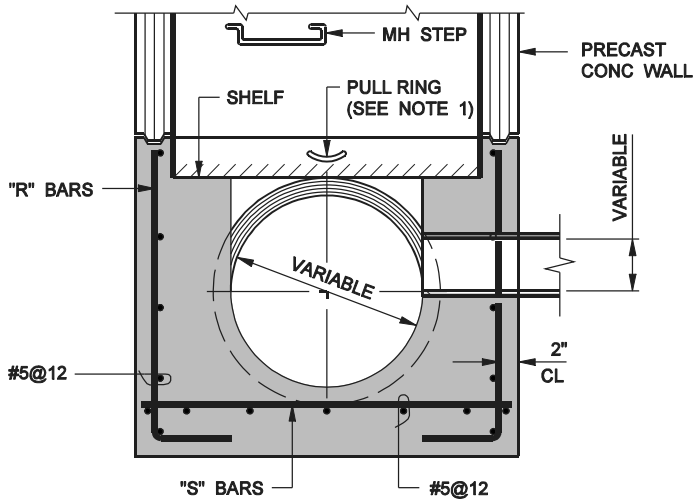

SECTION B-B

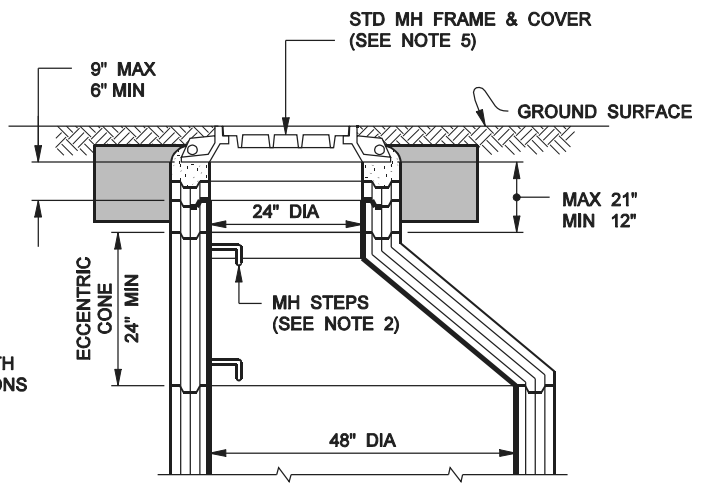

ALTERNATE SECTION MAY BE USED IF SPECIFIED IN BID DOCUMENTS

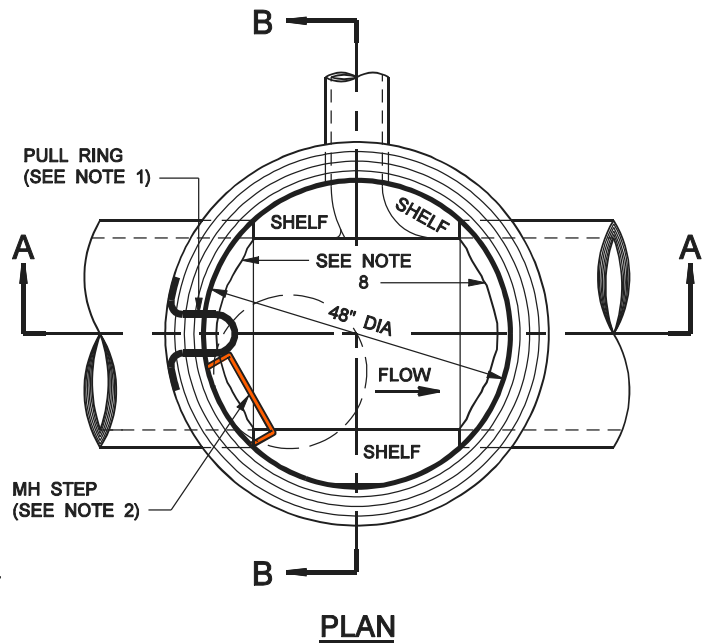

PLAN

TABLE OF REINFORCING BARS			
PIPE DIA	DEPTH TO INV	BARS "R"	BARS "S"
8" TO 21"	UP TO 15'	#5@12	#5@12
	16' TO 30'	#6@12	#6@12
24" TO 30"	UP TO 15'	#5@12	#5@12
	16' TO 30'	#7@12	#6@12

FOR 8" TO 30" PIPE

COUNTY SANITATION DISTRICTS OF LOS ANGELES COUNTY
OFFICE OF CHIEF ENGINEER

STEPHEN R. MAGUIN
CHIEF ENGINEER

STANDARD MANHOLE, TYPE "D"

STANDARD DRAWING
2006 EDITION
S - a - 2 0 4
SHEET 1 OF 3

NOTES:

1. ALL MANHOLES SHALL BE PROVIDED WITH A STANDARD PULL RING IN ACCORDANCE WITH S-a-220. THE PULL RING SHALL BE LOCATED 5" ABOVE THE TOP OF PIPE ON THE UPSTREAM SIDE OF THE MANHOLE AND ALONG THE AXIS OF THE DOWNSTREAM OUTLET. WHERE THE MANHOLE IS TO BE USED AS A DOWNSTREAM SIPHON MANHOLE, IT SHALL BE PROVIDED WITH AN ADDITIONAL STANDARD PULL RING, BUT LOCATED 5" ABOVE THE TOP OF PIPE ON THE DOWNSTREAM SIDE OF THE MANHOLE AND ON THE CENTERLINE OF THE UPSTREAM SIPHON PIPE.
2. MANHOLE STEPS SHALL BE IN ACCORDANCE WITH S-a-209 AND SHALL BE UNIFORMLY SPACED NOT MORE THAN 16" APART. THE TOP STEP SHALL BE PLACED WITHIN 16" BELOW THE MANHOLE FRAME. THE BOTTOM MANHOLE STEP SHALL BE PLACED WITHIN 16" ABOVE THE SHELF. IN MANHOLE SHAFTS 36" IN DIAMETER AND LARGER, THE MANHOLE STEP SHALL PROJECT 5". IN MANHOLE SHAFTS SMALLER THAN 36" IN DIAMETER, THE MANHOLE STEP SHALL PROJECT 4". THE MANHOLE STEPS SHALL BE PLACED SUCH THAT THEY ARE ADJACENT TO BUT NOT INTERFERING WITH ACCESS TO THE PULL RING.
3. THE MANHOLE SHALL BE PROVIDED WITH PLASTIC LINER WITH LOCKING EXTENSIONS. PLASTIC LINER WITH LOCKING EXTENSIONS SHALL BE IN ACCORDANCE WITH THE STANDARD SPECIFICATIONS. THE LINER SHALL EXTEND FROM THE BOTTOM OF THE ADJUSTING RINGS TO THE TOP OF THE SHELF. LINER RETURNS SHALL BE PROVIDED WHERE THE LINER TERMINATES AT THE ADJUSTING RING AND THE SHELF. THE JOINT BETWEEN THE LINER AND THE STAINLESS STEEL STEPS AND PULL RING SHALL BE THOROUGHLY SEALED WITH MASTIC SEAM MATERIAL AS MANUFACTURED BY LINABOND INC., SYLMAR, CALIFORNIA (818) 362-7373, OR EQUAL. APPLICATION OF SEALANT AND PREPARATION OF SURFACES SHALL BE IN STRICT CONFORMANCE WITH THE MANUFACTURER'S DIRECTIONS.
4. UNLESS OTHERWISE SPECIFIED, ALL CONCRETE SHALL BE 660-B-4000 ALL REINFORCING BARS SHALL BE DEFORMED BARS CONFORMING TO ASTM-A706 GRADE 60.
5. IN PAVED AREAS SUBJECT TO TRAFFIC, A 24" TRAFFIC MANHOLE FRAME AND COVER IN ACCORDANCE WITH S-a-228 SHALL BE PROVIDED. IN ALL OTHER AREAS, A 24" LOCKING MANHOLE FRAME AND COVER IN ACCORDANCE WITH S-a-207 SHALL BE PROVIDED. IF A 30" MANHOLE FRAME AND COVER IS REQUIRED, A FRAME AND COVER IN ACCORDANCE WITH S-a-223 SHALL BE PROVIDED AND INSTALLED WHERE THE REDUCER RING IS SHOWN AND THE REDUCER RING, 24" ADJUSTING RINGS, AND 24" FRAME AND COVER SHALL BE OMITTED.
6. A 12" WIDE BY 12" HIGH CONCRETE RING SHALL BE PROVIDED AROUND THE MANHOLE FRAME. IN UNPAVED AREAS, THE CONCRETE RING SHALL BE PROVIDED WITH #3 REBAR, 30 DIAMETER LAP.

COUNTY SANITATION DISTRICTS OF LOS ANGELES COUNTY
OFFICE OF CHIEF ENGINEER

STEPHEN R. MAGUIN
CHIEF ENGINEER

STANDARD MANHOLE, TYPE "D"

STANDARD DRAWING
2006 EDITION
S-a-204
SHEET 2 OF 3

NOTES:

7. EXCEPT AS NOTED HEREON, THE PRECAST UNITS SHALL BE MANUFACTURED AND TESTED IN ACCORDANCE WITH ASTM C478. THE CURING OF THE PRECAST UNITS SHALL CONFORM TO SECTION 207-2.7 OF THE STANDARD SPECIFICATIONS. AS AN ALTERNATE, THE UNITS MAY BE CURED USING SATURATED STEAM FOR A MINIMUM OF 12 HOURS FOLLOWED BY 6 DAYS OF WATER CURING OR MEMBRANE CURING. IF THE UNITS ARE CURED BY THE ALTERNATE METHOD, THEY SHALL NOT BE SHIPPED PRIOR TO 8 DAYS AFTER CASTING NOR UNTIL THE CONCRETE HAS ATTAINED A MINIMUM STRENGTH OF 4,000 PSI. THE RISER SECTIONS MAY BE REINFORCED OR UNREINFORCED. REINFORCED SECTIONS, INCLUDING ECCENTRIC CONES, SHALL HAVE A MINIMUM WALL THICKNESS OF 5" AND UNREINFORCED SECTIONS, INCLUDING CONES, SHALL HAVE A MINIMUM WALL THICKNESS OF 6". JOINTS SHALL BE TONGUE AND GROOVE AND SHALL BE ASSEMBLED USING CLASS "B" MORTAR. THE MORTARED JOINTS SHALL BE FLUSH AND TROWELED SMOOTH.

8. THE TOP PORTION OF THE PIPES WITHIN THE MANHOLE SHALL BE CUT OUT AS NECESSARY TO PROVIDE A CIRCULAR OPENING BETWEEN THE PIPE ENDS OF AT LEAST 42". THE CUT ENDS SHALL BE PLASTERED SMOOTH WITH CEMENT MORTAR FOR CONCRETE PIPE AND EPOXY FOR CLAY PIPE. THE CIRCULAR OPENING SHALL BE CUT PRIOR TO INSTALLATION OF THE RISER SECTIONS.

COUNTY SANITATION DISTRICTS OF LOS ANGELES COUNTY
OFFICE OF CHIEF ENGINEER

STEPHEN R. MAGUIN
CHIEF ENGINEER

STANDARD MANHOLE, TYPE "D"

STANDARD DRAWING
2006 EDITION

S-a-204

SHEET 3 OF 3