

# 3510Z 3510C Assembly (11 1/2")

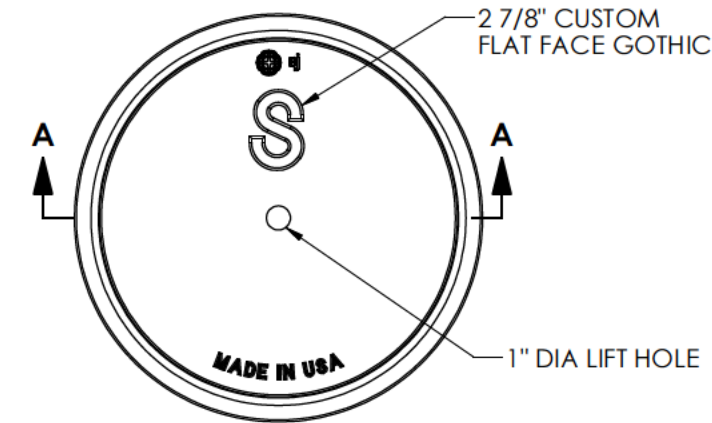

**ACCESS COVER**

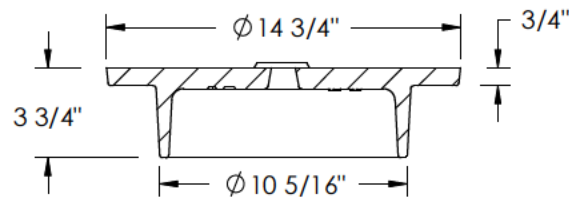

**ACCESS COVER SECTION A-A**

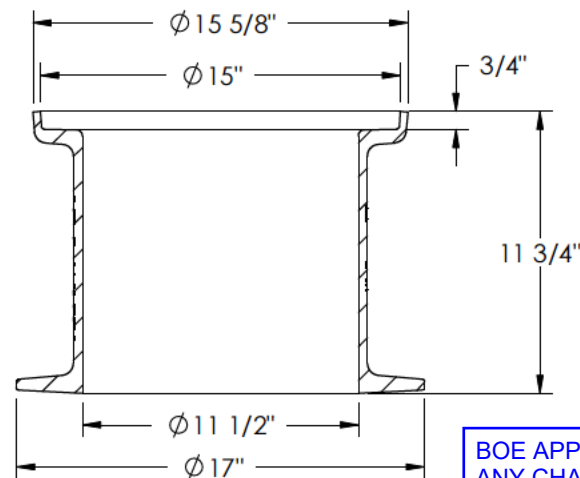

**ACCESS FRAME SECTION A-A**

**Product Number**

**Design Features**

- Materials
  - Cleanout/Monument Box Frame  
Gray Iron (CL35B)
  - Cleanout/Monument Box Cover  
Gray Iron (CL35B)
- Design Load  
Heavy Duty H20 (Traffic Loading)
- Open Area  
Buried Cover
- Coating  
Dipped
- √ Designates Machined Surface
- Cover Weight  
48 lb
- Frame Weight  
70 lb
- General Notes  
(See Page #2)

**Certification**

- ASTM A48 S-160
- H20
- Country of Origin: USA

**Major Components**

- 00351010
- 00351021

**Drawing Revision**

- 5/20/2024 Designer: JIJ
- 07/15/2024 Revised By: JIJ

**Disclaimer**

Weights (lbs/kg), dimensions (inches/mm) and drawings provided for your guidance. We reserve the right to modify specifications without prior notice.

CONFIDENTIAL: This drawing is the property of EJ Group, Inc. and embodies confidential information, registered marks, patents, trade secret information, and/or know-how that is the property of EJ Group, Inc. Copyright © 2013 EJ Group, Inc. All rights reserved.

**Contact**

800 626 4653  
ejco.com

**APPROVED**  
 September 16, 2024  
 DESIGN STANDARDS & INVESTIGATIONS  
 BUREAU OF ENGINEERING  
 CITY OF LOS ANGELES

BOE APPROVAL CONDITION  
 ANY CHANGES IN WEIGHT, DIMENSIONS,  
 AND/OR SPECIFICATIONS WILL REQUIRE DSIG  
 REVIEW AND RE-APPROVAL

# 3510Z 3510C Assembly General Notes



- 1) The access frame, cover, and cap shall be cast conforming to section 206-3 of the standard specifications. The finger holes may be drilled or blocked out prior to casting, they shall not be punched out.
- 2) The contractor, at his own option, may place either circular or square pipe wall supports as shown hereon.
- 3) Cover & frame shall be encased in concrete