

1770A DI 1771Z2 ASSEMBLY

PRODUCT NUMBER

00177104

DESIGN FEATURES

MATERIALS

COVER-DUCTILE IRON
ASTM A536

FRAME-GRAY IRON
ASTM A48 CL35B

DESIGN LOAD

EXTRA HEAVY DUTY
AIRPORT AND PORT AUTHORITY

(PROOF LOAD TESTED
TO 220,000 LBS.)

COATING

UNDIPPED

OPEN AREA

N/A

√ DESIGNATES MACHINE SURFACE

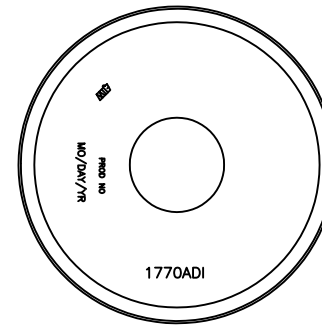
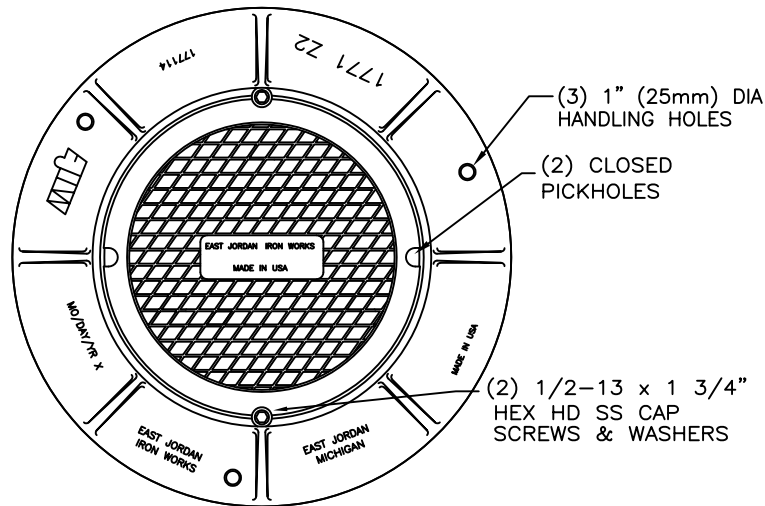

BOTTOM VIEW
OF COVER

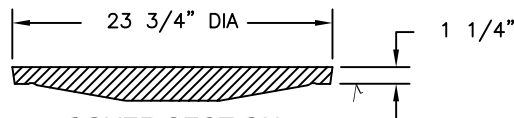

COVER SECTION

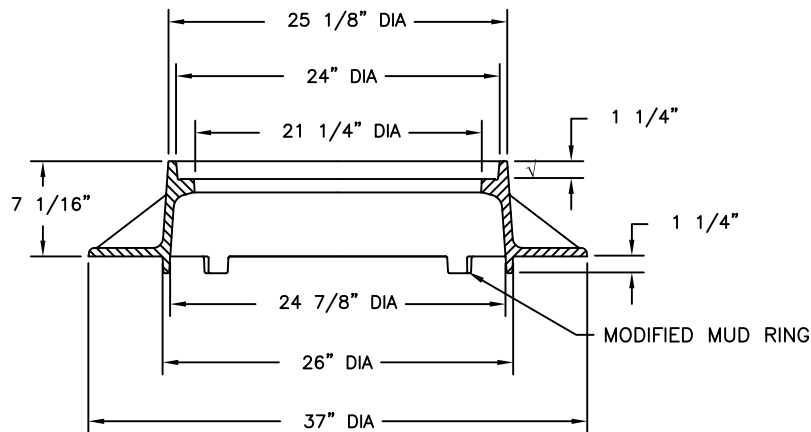

FRAME SECTION

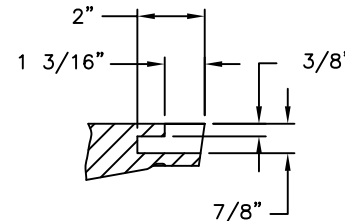

PICKHOLE DETAIL

Corporate
Headquarters
301 Spring Street
PO Box 439
East Jordan, MI
49727-0439
800.874.4100



Call Today for
More Information

800.626.4653

EJIW EAST JORDAN
IRON WORKS EST 1883
WE COVER YOUR INFRASTRUCTURE

www.ejiw.com
MADE IN THE USA

- Weights (lbs./kg.) dimensions (inches/mm.), and drawings provided for your guidance.
- We reserve the right to modify specifications without prior notice.
- Uncontrolled distribution.

CONFIDENTIAL: This drawing is the property of East Jordan Iron works, Inc., and embodies confidential information, registered marks, trade secret information, and/or know how that is the property of East Jordan Iron Works, Inc. ©Copyright 2009 East Jordan Iron Works, Inc.

REFERENCE INFORMATION

00177021

00177114

DRAWING DETAILS

ORIGINAL DRAWING: SBB 04/18/05

REVISED BY: DEW 07/06/10