

5440Z 5440MDI BOLTED ASSEMBLY

PRODUCT NUMBER

00544004

DESIGN FEATURES

MATERIALS

GRATE-DUCTILE IRON
ASTM A536 GR 80-55-06
FRAME-GRAY IRON
ASTM A48 CL35B

DESIGN LOAD

EXTRA HEAVY DUTY
(PROOF LOAD TESTED
TO 200,000 LBS.)

COATING

DIPPED

OPEN AREA

N/A

√ DESIGNATES MACHINE SURFACE

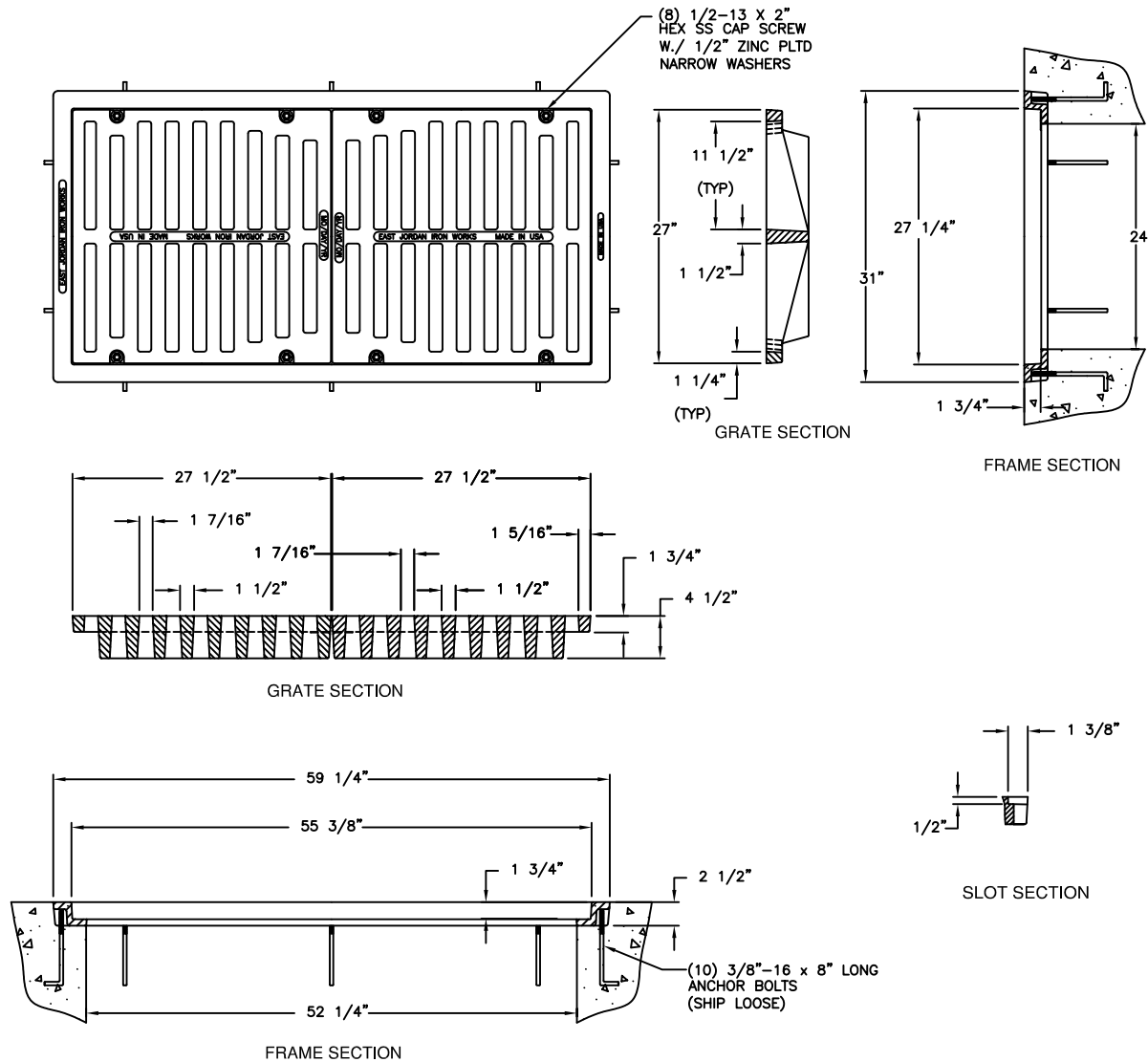

Corporate
Headquarters
301 Spring Street
PO Box 439
East Jordan, MI
49727-0439
800.874.4100



Call Today for
More Information

800.626.4653

EJIW EAST JORDAN
IRON WORKS EST. 1883
WE COVER YOUR INFRASTRUCTURE

www.ejiw.com
MADE IN THE USA

- Weights (lbs./kg.), dimensions (inches/mm.), and drawings provided for your guidance.
- We reserve the right to modify specifications without prior notice.
- Uncontrolled distribution.

CONFIDENTIAL: This drawing is the property of East Jordan Iron works, Inc., and embodies confidential information, registered marks, trade secret information, and/or know how that is the property of East Jordan Iron Works, Inc. ©Copyright 2009 East Jordan Iron Works, Inc.

REFERENCE INFORMATION

00544010
00544030

DRAWING DETAILS

ORIGINAL DRAWING: DEW 05/26/04

REVISED BY: DEW 03/30/10