



**LBIW Inc.**

2020 WEST 14TH STREET  
 LONG BEACH, CA. 90813  
 Tel No. : (562) 432.5451  
 Fax No. : (562) 435.5929  
 www.lbiw.com

**PRODUCT NUMBER**  
**48R GRATE**  
 NOT BICYCLE FRIENDLY

**COATING**  
 GALVANIZED OR MILL FINISH (UNCOATED)

**SPECIFICATIONS**  
**MATERIAL** : ASTM A36  
**COATING** : ASTM A123

**MADE IN USA**

**EST. WEIGHT**  
 315 LBS  
 WEIGHTS MAY VARY  
 MINUS 5%, PLUS 10%

**DRAWN** : EB  
**DATE** : 06-08-09

**REVISED**  
 06-11-09

**REFERENCE INFORMATION**

SECTION 08

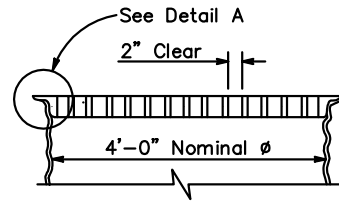

SECTION

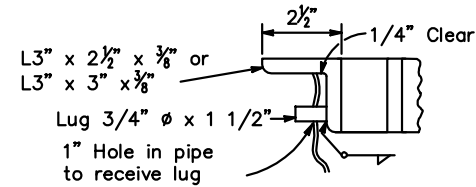

DETAIL A

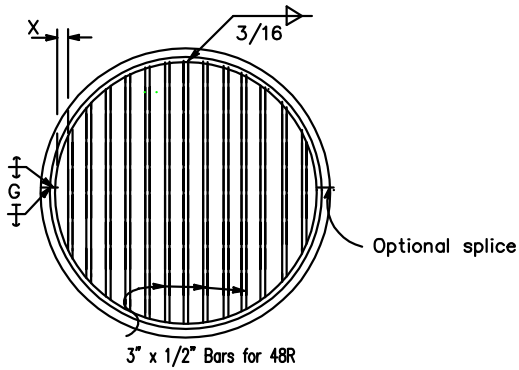

PLAN

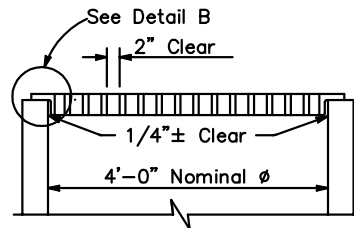

SECTION

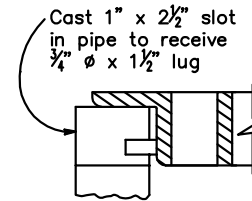

DETAIL B

GRATE BAR SPACING TABLE

| TYPE | No. OF BARS | CLEAR BAR SPACING | X      |
|------|-------------|-------------------|--------|
| 48R  | 17          | 2"                | 2 1/8" |