



Tel no. : (562) 528-0258
www.ejco.com



LBIW Inc.

2020 WEST 14TH STREET
LONG BEACH, CA. 90813
Tel No. : (562) 432.5451
Fax No. : (562) 435.5929
www.lbiw.com

STANDARD PLAN REFERENCE

SPPWC (APWA) 312-4

*CATCH BASIN MANHOLE
FRAME AND COVER

PRODUCT NUMBER

LB 1530/X-110
EJ 3113004

ESTIMATED WEIGHTS

COVER: 85 LBS (40 Kg)
FRAME: 30 LBS (15 Kg)
UNIT: 115 LBS (55 Kg)
Weights may vary
Minus 5%, Plus 10%

MATERIALS SPECIFICATIONS

COVER: GRAY IRON
ASTM A48 CL35B
FRAME: GRAY IRON
ASTM A48 CL35B
CAST GRAY IRON CONFORMING TO SECTION
206-3 OF THE STANDARD SPECIFICATIONS
FOR PUBLIC WORKS CONSTRUCTION

COATING

HOT DIPPED GALVANIZED
GREEN BOOK SPPWC (APWA)
PARAGRAPH 210-3- "GALVANIZING"
AASHTO M111/ASTM A123
BITUMINOUS COATING (PAINTED BLACK)

DESIGN LOAD RATING

LIGHT DUTY (NON-TRAFFIC) LOADING ONLY

✓ DESIGNATES MACHINED
SURFACE

Drawn: GRA	Date: 06-16-16
----------------------	--------------------------

COMPONENT INFORMATION

00311024 COVER
00311012 FRAME

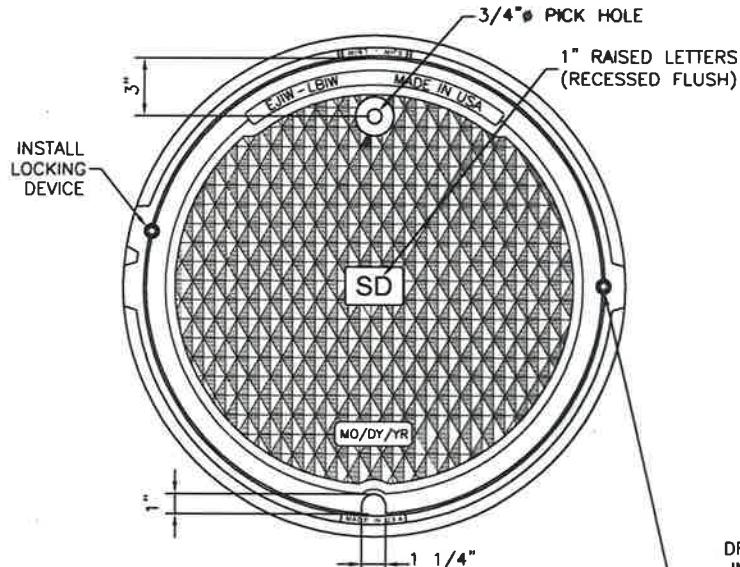

PLAN VIEW

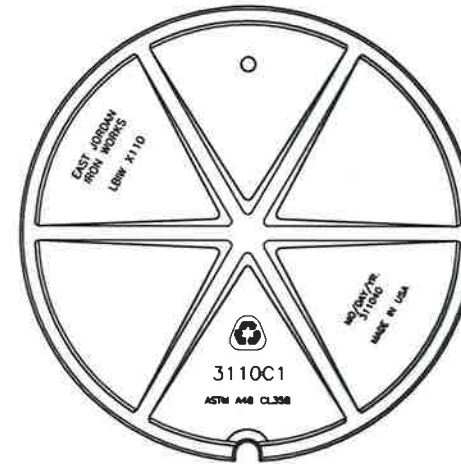

BOTTOM VIEW

DRILL AND TAP HOLE AND
INSTALL 20mm X 32mm
(3/4" X 1 1/4") SS SOCKET
SET SCREW W/ 10mm
(3/8") RECESSED HEX HOLE
ALL THREAD TO BE NC



LOCKING DEVICE

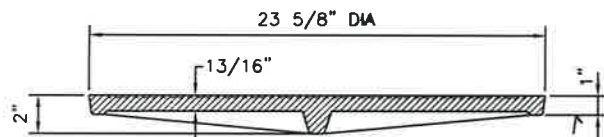

COVER SECTION

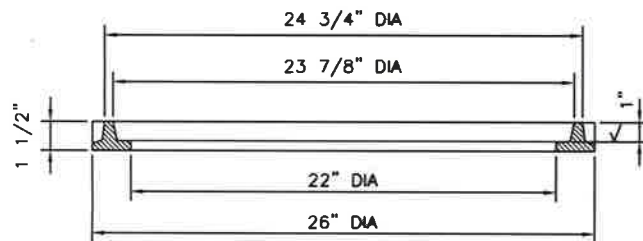

FRAME SECTION

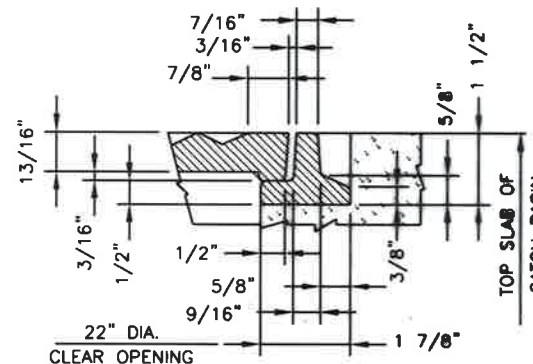

SEATING DETAIL

DIMENSIONAL TOLERANCES SHALL BE $\pm 1/8$ "
CASTING SHALL EXCEED PROOFLOAD OF 28,600 LBS.

CONFIDENTIAL: This drawing is the property of EJ Group, Inc. and embodies confidential information, trade secret information, and/or know how that is the property of EJ Group, Inc. © Copyright 2012 East Jordan Iron Works, Inc.