

7585Z1/7585M1 DI ASSEMBLY

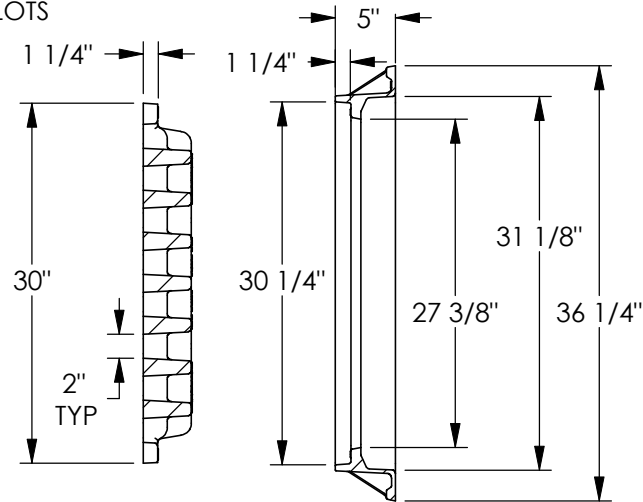

(4) 1/2"-13 HEX HD. BOLTS WITH SS WASHERS

SECTION A-A

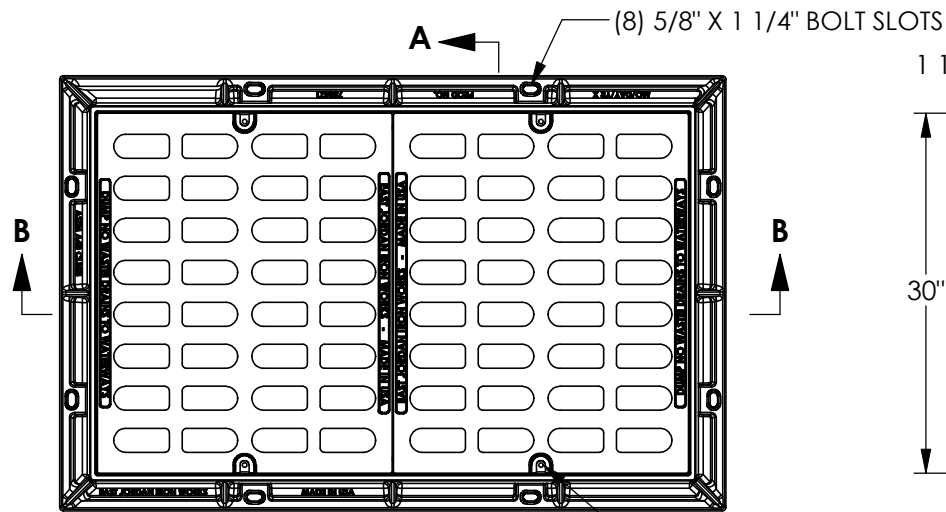
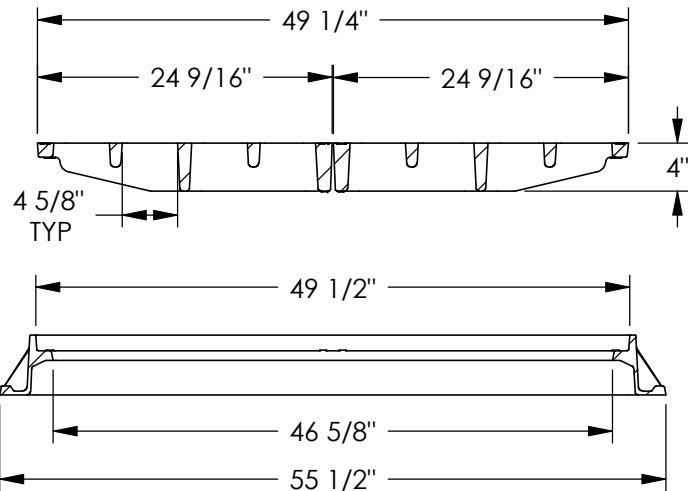

SECTION B-B

PRODUCT NUMBER

00758537B01

DESIGN FEATURES

MATERIALS

GRATE-DUCTILE IRON
ASTM A536

FRAME-GRAY IRON
ASTM A48 CL35B

DESIGN LOAD

EXTRA HEAVY DUTY
(DESIGNED TO MEET
245,000 LB. LOAD)

COATING

UNDIPPED

OPEN AREA

560 SQ. INCHES

✓ DESIGNATES MACHINE SURFACE

REFERENCE INFORMATION

00758515

00758537

DRAWING DETAILS

ORIGINAL DRAWING: DEW 2/4/2010

REVISED BY: DEW 2/4/2010

Corporate
Headquarters
301 Spring Street
PO Box 439
East Jordan, MI
49727-0439
800.874.4100



Call Today for
More Information

800.626.4653

EJIW EAST JORDAN
IRON WORKS EST. 1883
WE COVER YOUR INFRASTRUCTURE®

www.ejiw.com
MADE IN THE USA

- Weights (lbs./kg.), dimensions (inches/mm.), and drawings provided for your guidance.
- We reserve the right to modify specifications without prior notice.
- Uncontrolled distribution.

CONFIDENTIAL: This drawing is the property of East Jordan Iron works, Inc., and embodies confidential information, registered marks, trade secret information, and/or know how that is the property of East Jordan Iron Works, Inc. ©Copyright 2009 East Jordan Iron Works, Inc.