

SIDE VIEW

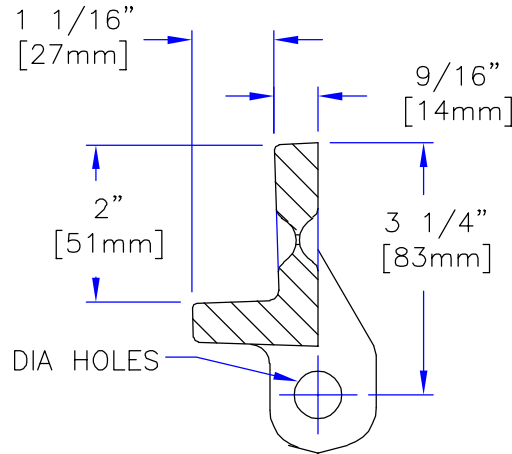

(4) 5/8" (16mm) DIA HOLES FOR #3 REBAR

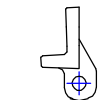
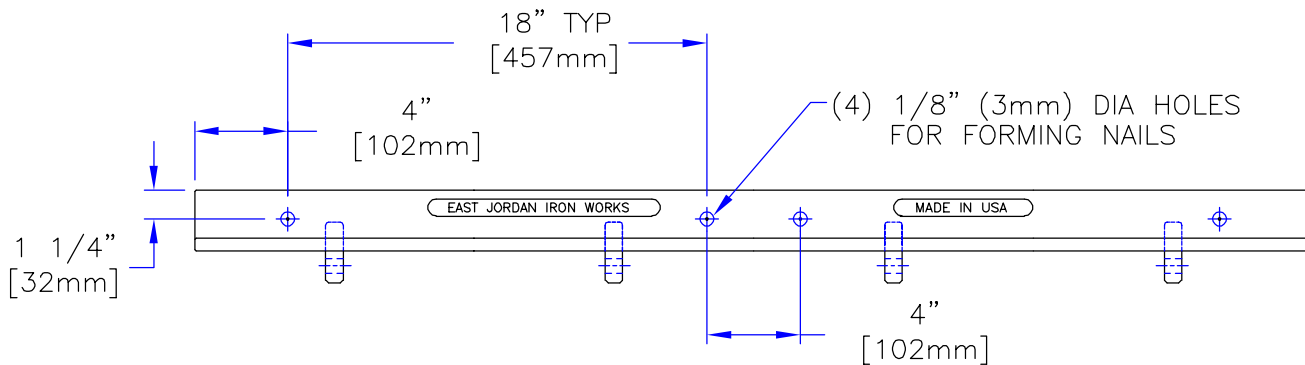

SIDE VIEW

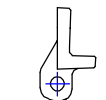
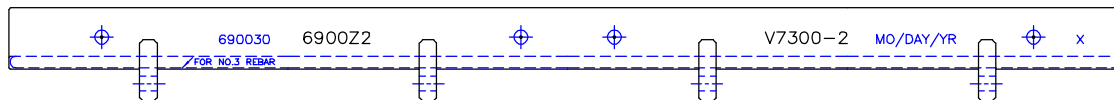

SIDE VIEW

EAST JORDAN  
IRON WORKS, INC.  
P.O. BOX 439  
EAST JORDAN, MI. 49727  
1-800-874-4100  
FAX 231-536-4458

DRAWN SBB	DATE 04/14/03
APPROVED	DATE

48" TRENCH  
FRAME

PRODUCT NO.  
00690030

CATALOG NO.  
6900Z2  
DIPPED

REF. PRODUCT DRAWING  
690030

EST. WT.  
FRAME: 26 LBS 12kg

OPEN AREA  
N/A

MAT'L SPEC.  
FRAME - GRAY IRON  
ASTM A48 CL35

LOAD RATING  
HEAVY DUTY