

TYPE GO

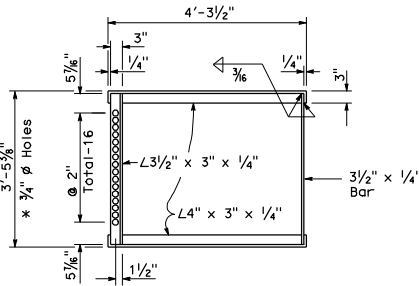

* 3/4" ϕ Holes required only with trash rack

GRATE FRAME FOR TYPE GDO INLET

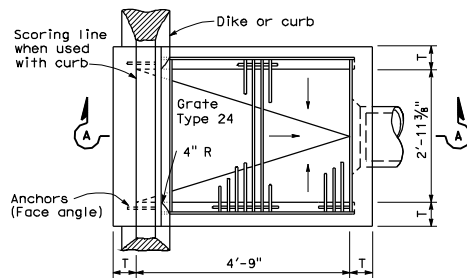

TYPE GDO

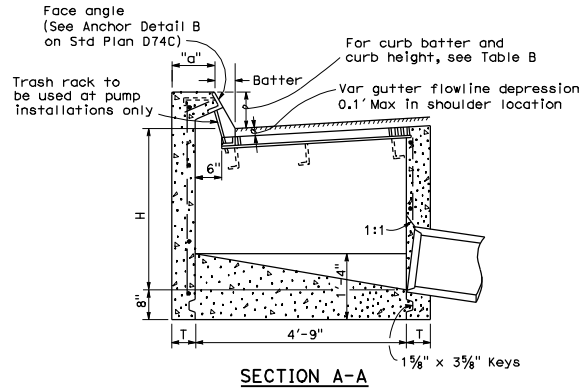

SECTION A-A

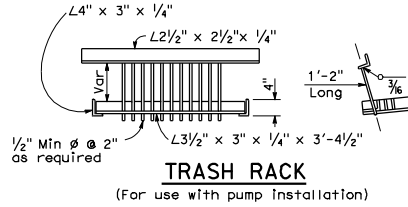

TRASH RACK
(For use with pump installation)

TABLE A
CONCRETE QUANTITIES

TYPE	H=3'-0" TO 8'-0" (T=6")		H=8'-1" TO 20'-0" (T=8")	
	H=3'-0" (CY)	ADDITIONAL PCC PER FOOT (CY)	H=8'-1" (CY)	ADDITIONAL PCC PER FOOT (CY)
GO	1.24	0.245	3.39	0.346
GDO	1.62	0.322	4.36	0.446

Table based on 8" floor slab, no deduction for pipe openings, and curb type giving highest quantity of concrete. No deductions or adjustments are to be made to these quantities because of pipe openings, different floor alternatives or different curb type.

TABLE B

CURB TYPE	NORMAL CURB HEIGHT	CURB BATTER	"a" DIMENSION	"b" DIMENSION
A1-6	6"	1/2"	T+7 1/2"	T+6 1/2"
A1-8	8"	2"	T+7"	T+6"
B1-6	6"	4"	T+5"	T+4"
Type A Dike	6"	3"	T+6"	T+5"

DIST	COUNTY	ROUTE	POST MILES TOTAL PROJECT	SHEET NO.	TOTAL SHEETS
REGISTERED CIVIL ENGINEER					
June 15, 2007 PLANS APPROVAL DATE					
To accompany plans dated _____					

NOTES:

- "H" is the difference in elevation between the outlet pipe flow line and the normal gutter grade line undepressed.
- For "T" wall thickness, see Table A below.
- Wall reinforcing not required when "H" is 8'-0" or less and the unsupported width or length is 7'-0" or less. Walls exceeding these limits shall be reinforced with #4 @ 18" centers placed 1/2" clear to inside of box unless otherwise shown.
- Inlet bottom reinforcing not required. See Standard Plan D74C for alternative reinforced bottom.
- Steps - None required where "H" is less than 2'-6" Where "H" is 2'-6" or more, install steps with lowest rung 1'-0" above the floor and highest rung not more than 6" below top of inlet. The distance between steps shall not exceed 1'-0" and shall be uniform throughout the length of the wall. Place steps in the wall without an opening. Step inserts may be substituted for the bar steps. Step inserts shall comply with State Industrial Safety requirements. See Standard Plan D74C for step details.
- When shown on the project plans, place a 3/4" plain round protection bar horizontally across the length of the opening and bend back 4" into the inlet wall on each side.
- Pipe(s) can be placed in any wall.
- Curb section shall match adjacent curb.
- Basin floors shall have wood trowel finish and shall slope toward the outlet pipe as shown.
- Galvanizing - See Standard Specifications or Special Provisions.
- See Standard Plan D77A and D77B for grate and frame details and weights of miscellaneous iron and steel.
- See Standard Plan D78A for gutter depression details.
- Full penetration butt welds may be substituted for the fillet welds on all anchors.
- Standard square, hexagon, round or equivalent headed anchors may be substituted for the right angle hooks on the anchors shown on this plan.
- Cast-in-place or precast alternative is optional with contractor. See Standard Specifications.
- Cast-in-place inlets to be formed around all pipes/stubs intersecting the inlet and concrete poured in one continuous operation. Precast inlets shall have mortared pipe connections conforming to details for Type GCP inlets on Standard Plan D75B. See Standard Specifications for mortar composition.

STATE OF CALIFORNIA
DEPARTMENT OF TRANSPORTATION
DRAINAGE INLETS
NO SCALE

RSP D74B DATED JUNE 15, 2007 SUPERSEDES STANDARD PLAN D74B
DATED MAY 1, 2006 - PAGE 150 OF THE STANDARD PLANS BOOK DATED MAY 2006.
REVISED STANDARD PLAN RSP D74B

2006 REVISED STANDARD PLAN RSP D74B