

FLOGARD+PLUS® FILTER
-INSTALLED INTO CATCH BASIN-

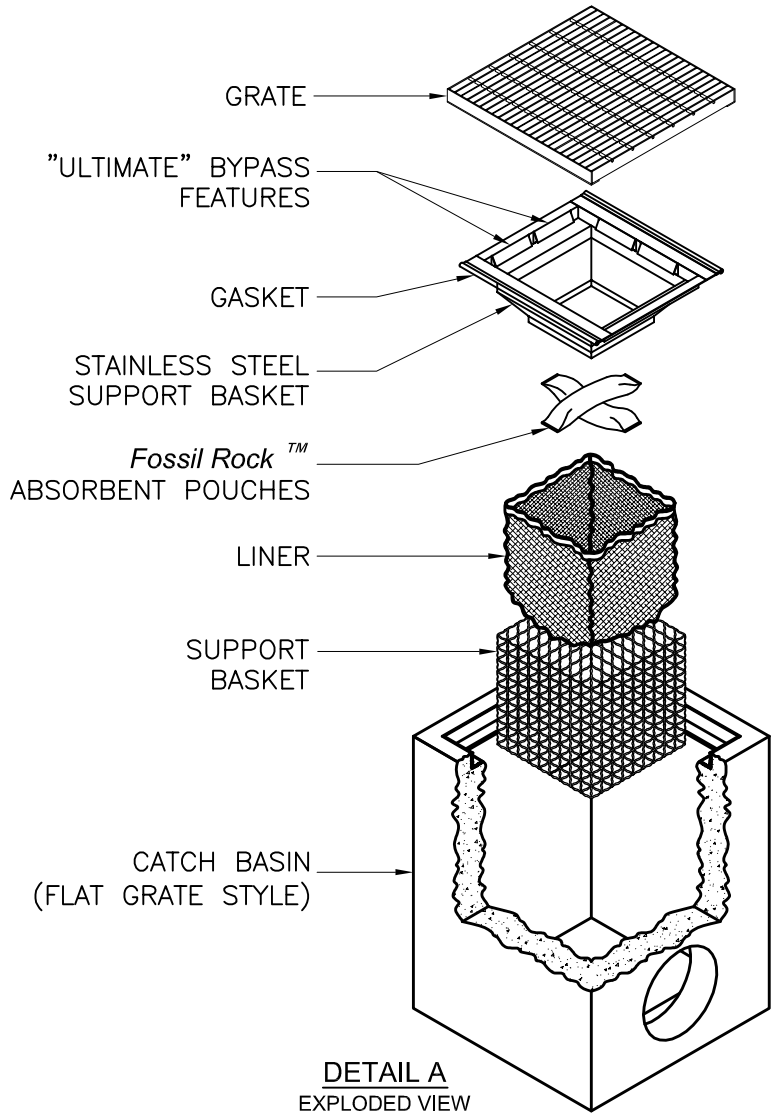

DETAIL A
EXPLODED VIEW

NOTES:

1. FloGard®+Plus (frame mount) high capacity catch basin inserts are available in most sizes and styles (see specifier chart, sheet 2 of 2). Refer to the FloGard®+Plus (wall mount) insert for devices to fit non-standard, or combination style catch basins.
2. Filter insert shall have both an "initial" filtering bypass and "ultimate" high flow bypass feature.
3. Filter support frame shall be constructed from stainless steel Type 304.
4. Allow a minimum of 2.0 feet, of clearance between the bottom of the grate and top of outlet pipe(s), or refer to the FloGard® insert for "shallow" installations.
5. Filter medium shall be *Fossil Rock™*, installed and maintained in accordance with manufacturer specifications.
6. Storage capacity reflects 80% of maximum solids collection prior to impeding filtering bypass.
7. Filtered flow r/rate includes a safety factor of two.

U.S. PATENT # 6,00,023 & 6,877,029

TITLE

FloGard® +PLUS
CATCH BASIN FILTER INSERT
(Flat Grated Inlet Style)



KriStar Enterprises, Inc.

360 Sutton Place, Santa Rosa, CA 95407
Ph: 800.579.8819, Fax: 707.524.8186, www.kristar.com

DRAWING NO. FGP-0001	REV D	ECO 0059 JPR 12/30/08	DATE JPR 11/3/06	SHEET 1 OF 2
-------------------------	----------	--------------------------	---------------------	--------------

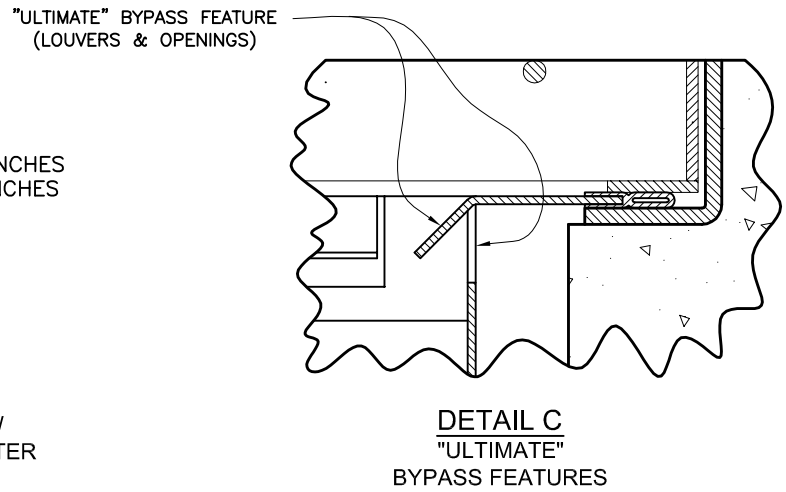
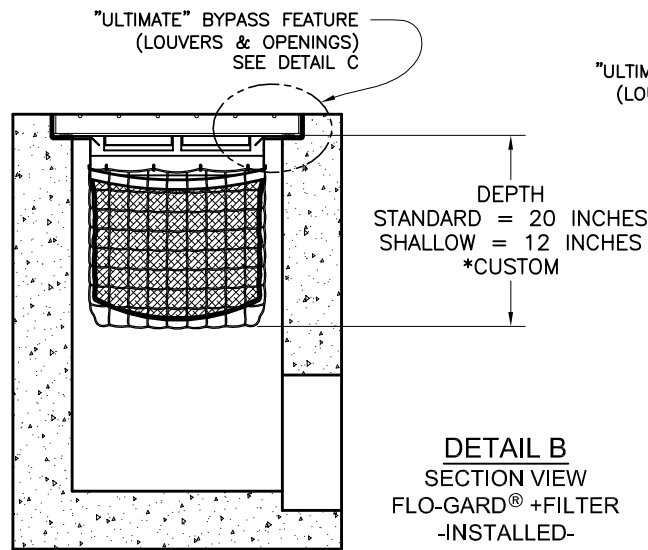

* MANY OTHER STANDARD & CUSTOM SIZES & DEPTHS AVAILABLE UPON REQUEST.

SPECIFIER CHART								
MODEL NO. STANDARD DEPTH	STANDARD & SHALLOW DEPTH (Data in these columns is the same for both STANDARD & SHALLOW versions)			STANDARD DEPTH -20 Inches-		MODEL NO. SHALLOW DEPTH	SHALLOW DEPTH -12 Inches-	
	INLET ID Inside Dimension (inch x inch)	GRATE OD Outside Dimension (inch x inch)	TOTAL BYPASS CAPACITY (cu. ft. / sec.)	SOLIDS STORAGE CAPACITY (cu. ft.)	FILTERED FLOW (cu. ft. / sec.)		SOLIDS STORAGE CAPACITY (cu. ft.)	FILTERED FLOW (cu. ft. / sec.)
FGP-12F	12 X 12	12 X 14	2.8	0.3	0.4	FGP-12F8	.15	.25
FGP-1530F	15 X 30	15 X 35	6.9	2.3	1.6	FGP-1530F8	1.3	.9
FGP-16F	16 X 16	16 X 19	4.7	0.8	0.7	FGP-16F8	.45	.4
FGP-1624F	16 X 24	16 X 26	5.0	1.5	1.2	FGP-1624F8	.85	.7
FGP-18F	18 X 18	18 X 20	4.7	0.8	0.7	FGP-18F8	.45	.4
FGP-1820F	16 X 19	18 X 21	5.9	2.1	1.4	FGP-1820F8	1.2	.8
FGP-1824F	16 X 22	18 X 24	5.0	1.5	1.2	FGP-1824F8	.85	.7
FGP-1836F	18 X 36	18 X 40	6.9	2.3	1.6	FGP-1836F8	1.3	.9
FGP-2024F	18 X 22	20 X 24	5.9	1.2	1.0	FGP-2024F8	.7	.55
FGP-21F	22 X 22	22 X 24	6.1	2.2	1.5	FGP-21F8	1.25	.85
FGP-2142F	21 X 40	24 X 40	9.1	4.3	2.4	FGP-2142F8	2.45	1.35
FGP-2148F	19 X 46	22 X 48	9.8	4.7	2.6	FGP-2148F8	2.7	1.5
FGP-24F	24 X 24	24 X 27	6.1	2.2	1.5	FGP-24F8	1.25	.85
FGP-2430F	24 X 30	26 X 30	7.0	2.8	1.8	FGP-2430F8	1.6	1.05
FGP-2436F	24 X 36	24 X 40	8.0	3.4	2.0	FGP-2436F8	1.95	1.15
FGP-2448F	24 X 48	26 X 48	9.3	4.4	2.4	FGP-2448F8	2.5	1.35
FGP-28F	28 X 28	32 X 32	6.3	2.2	1.5	FGP-28F8	1.25	.85
FGP-2440F	24 X 36	28 X 40	8.3	4.2	2.3	FGP-2440F8	2.4	1.3
FGP-30F	30 X 30	30 X 34	8.1	3.6	2.0	FGP-30F8	2.05	1.15
FGP-36F	36 X 36	36 X 40	9.1	4.6	2.4	FGP-36F8	2.65	1.35
FGP-3648F	36 X 48	40 X 48	11.5	6.8	3.2	FGP-3648F8	3.9	1.85
FGP-48F	48 X 48	48 X 54	13.2	9.5	3.9	FGP-48F8	5.45	2.25
FGP-SD24F	24 X 24	28 X 28	6.1	2.2	1.5	FGP-SD24F8	1.25	.85
FGP-1836FGO	18 X 36	20 X 40	6.9	2.3	1.6	FGP-1836F8GO	1.3	.9
FGP-2436FGO	20 X 36	24 X 40	8.0	3.4	2.0	FGP-2436F8GO	1.95	1.15
FGP-48FGO	18 X 48	20 X 54	6.3	2.2	1.5	FGP-48F8GO	1.25	.85

TITLE

FLO-GARD® +PLUS
CATCH BASIN FILTER INSERT
(Flat Grated Inlet Style)



KriStar Enterprises, Inc.

360 Sutton Place, Santa Rosa, CA 95407
Ph: 800.579.8819, Fax: 707.524.8186, www.kristar.com