

PRODUCT NUMBER

00690101

CATALOG NUMBER

6901M
6900Z1

TRENCH GRATE ASSEMBLY

LOAD RATING

EXTRA HEAVY DUTY
-200,000 LBS
90,719 kg

COATING

UNDIPPED

MATERIAL SPECIFICATION

GRATE - GRAY IRON
ASTM A48 CL35B
FRAME - GRAY IRON
ASTM A48 CL35B

OPEN AREA
40 SQ. IN/FT

√ DESIGNATES MACHINED SURFACE

DRAWN DEW	DATE 07/26/04
--------------	------------------

LAST REVISED SMM	DATE 02/02/11
---------------------	------------------

REFERENCE INFORMATION

00690023
00690130

CAUTION: DO NOT DISASSEMBLE BOLTED GRATES AND CHECK FRAME WIDTH INSIDE BEFORE SETTING SECTIONS IN CONCRETE.

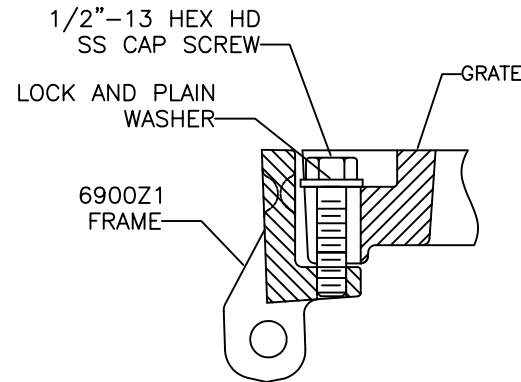

BOLT DETAIL

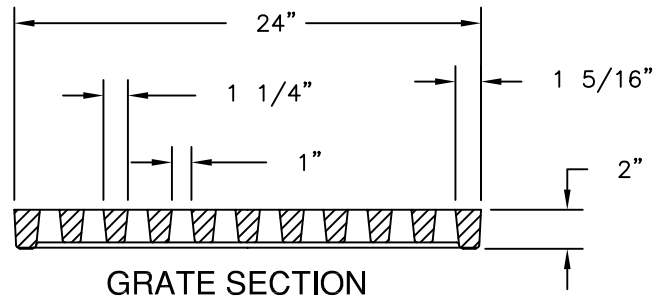
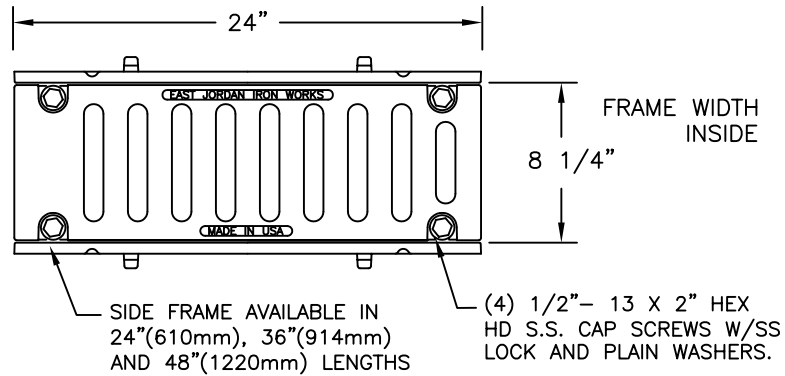

GRATE SECTION

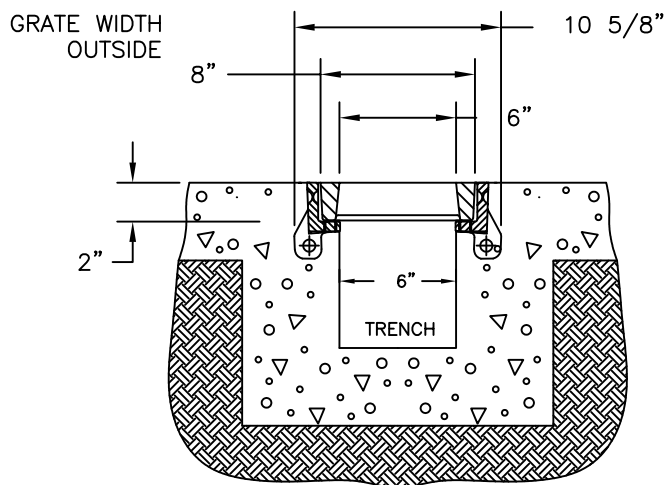

SECTION

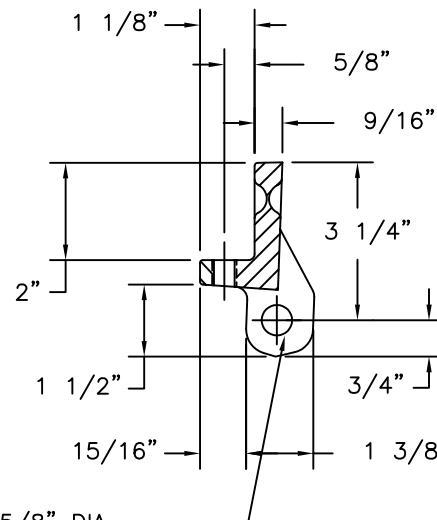

FRAME DETAIL

(2) 5/8" DIA
HOLES FOR #3 REBAR