

### SPECIFIER CHART

MODEL	INLET ID	GRATE OD	COMMENTS
FF-16D	16" X 16"	18" X 18"	GRATED INLET
FF-18D	18" X 18"	20" X 20"	GRATED INLET
FF-1836SD	18" X 36"	18" X 40"	GRATED INLET
FF-1836DGO	18" X 36"	18" X 40"	COMBINATION INLET
FF-24D	24" X 24"	26" X 26"	GRATED INLET
FF-2436D	24" X 36"	24" X 40"	GRATED INLET
FF-RF24D	24" DIA.	25" DIA.	CIRCULAR INLET
FF-24DGO	24" X 24"	18" X 26"	COMBINATION INLET
FF-2436DGO	24" X 36"	24" X 40"	COMBINATION INLET
FF-36D (2 PIECE)	36" X 36"	36" X 40"	GRATED INLET
FF-3648D (2 PIECE)	36" X 48"	40" X 48"	GRATED INLET

OPTIONAL FOSSIL ROCK ABSORBANT POUCHES  
FOUR EACH.

STAINLESS STEEL FILTER FRAME  
WITH RUBBER GASKET.

POLYPROPYLENE GEOTEXTILE  
FILTER ELEMENT.

STAINLESS STEEL SUPPORT HOOK.  
FOUR EACH.

**NOTES:**

1. FloGard® filter body is prefabricated from polypropylene woven monofilament geotextile.
2. All metal components shall be constructed from stainless steel Type 304.
3. Refer to Specifier Chart for catch basin and filter sizing.
4. Filter inserts are supplied with optional "clip-in" filter pouches utilizing fossil rock™ filter medium for the collection and retention of petroleum hydrocarbons (oils & greases).
5. FloGard® filter inserts and fossil rock™ filter medium pouches must be maintained in accordance with manufacturer recommendations.
6. Catch basin depth must not allow filter body to obstruct outlet pipe. See sheet 2 of 2.

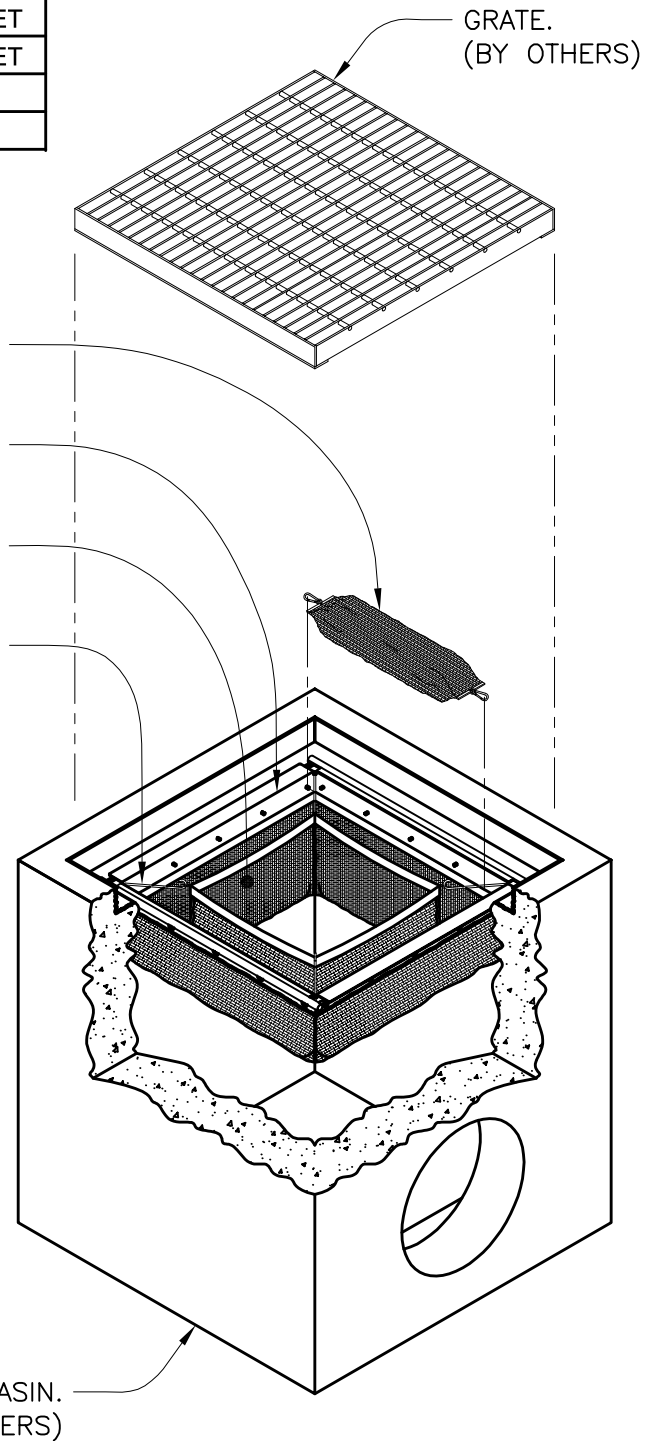

TITLE



**CATCH BASIN FILTER INSERT**



**KriStar Enterprises, Inc.**

360 Sutton Place, Santa Rosa, CA 95407  
Ph: 800.579.8819, Fax: 707.524.8186, www.kristar.com

DRAWING NO. FG-0001	REV B	ECO 0059 JPR 12/30/08	DATE JPR 12/18/06	SHEET 1 OF 2
------------------------	----------	--------------------------	----------------------	--------------

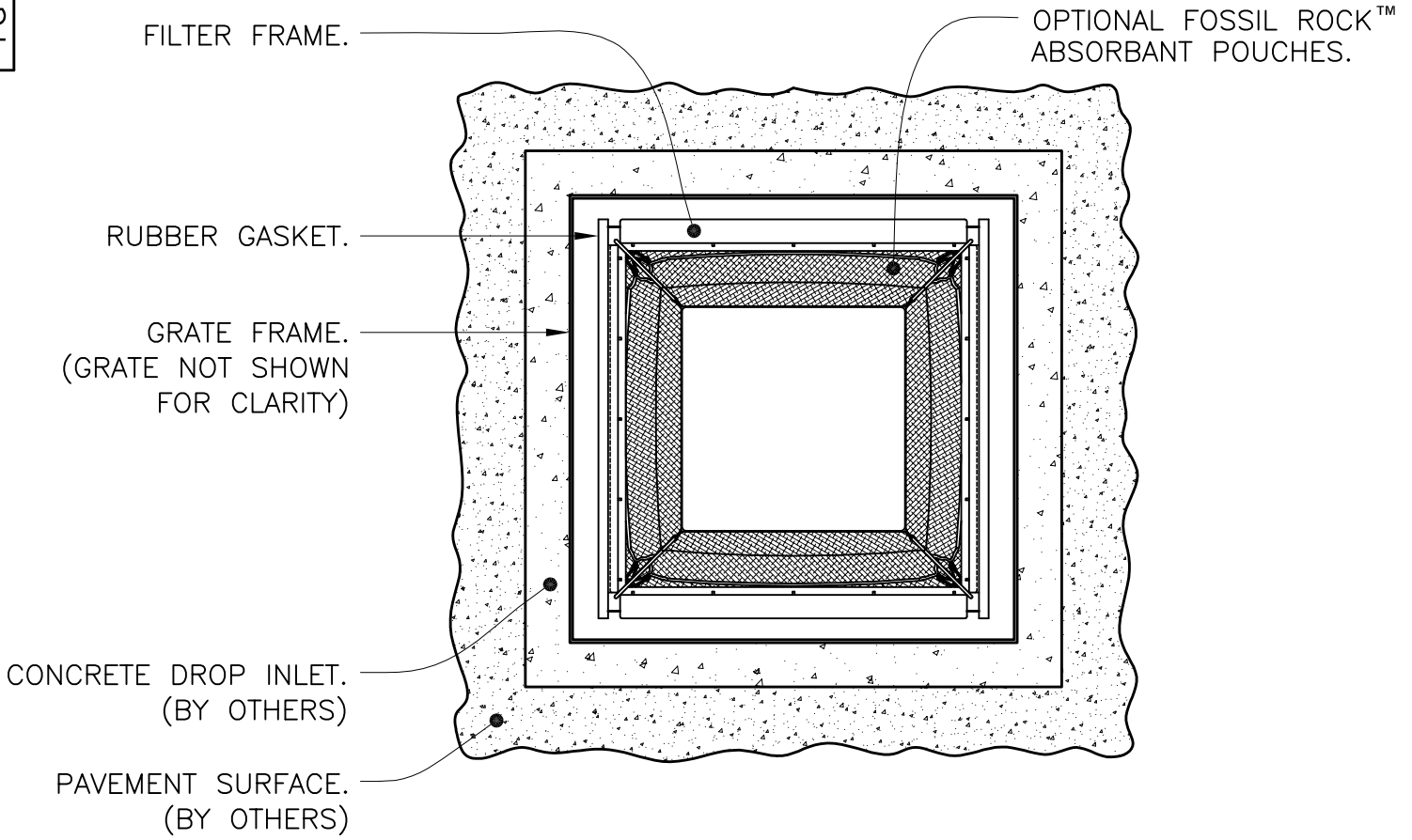

REFER TO SPECIFIER CHART FOR CATCH BASIN & FILTER SIZING. SEE SHEET 1 OF 2.

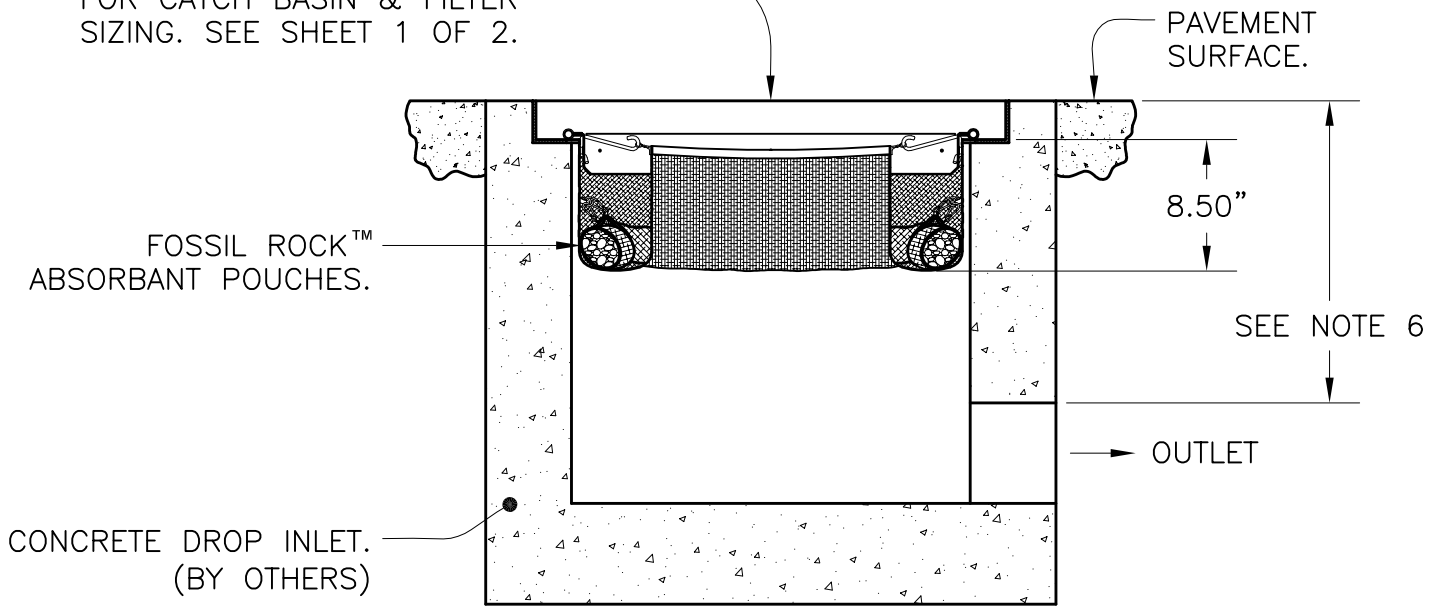

**SECTION VIEW**

TITLE



**CATCH BASIN FILTER INSERT**



**KriStar Enterprises, Inc.**

360 Sutton Place, Santa Rosa, CA 95407  
 Ph: 800.579.8819, Fax: 707.524.8186, www.kristar.com

DRAWING NO. FG-0001	REV B	ECO 0059 JPR 12/30/08	DATE JPR 12/18/06	SHEET 2 OF 2
------------------------	----------	--------------------------	----------------------	--------------