

PRODUCT NUMBER

00132405

CATALOG NUMBER

**1324M DI
1324ZPT**

1324 ASSEMBLY

LOAD RATING

**EXTRA HEAVY DUTY
PROOF LOAD TESTED - 200,000 LBS
90,719 KG**

COATING

DIPPED

ESTIMATED WEIGHT

GRATE: 269 LBS 122kg
FRAME: 270 LBS 123kg
UNIT: 539 LBS 245kg

MATERIAL SPECIFICATION

GRATE - DUCTILE IRON
ASTM A536

FRAME - GRAY IRON
ASTM A48 CL35B

OPEN AREA

270 sq. in. [1742 sq. cm.]

✓ DESIGNATES MACHINED SURFACE

DRAWN

SBB

DATE

04/02/07

LAST REVISED

DATE

REFERENCE INFORMATION

00132430
00132412

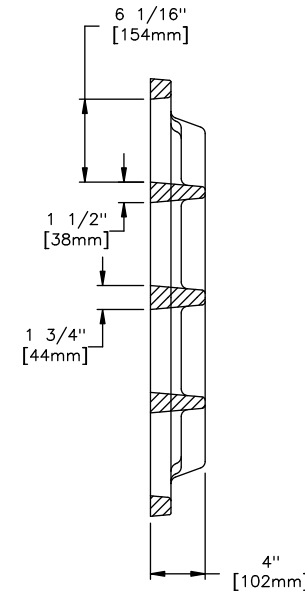
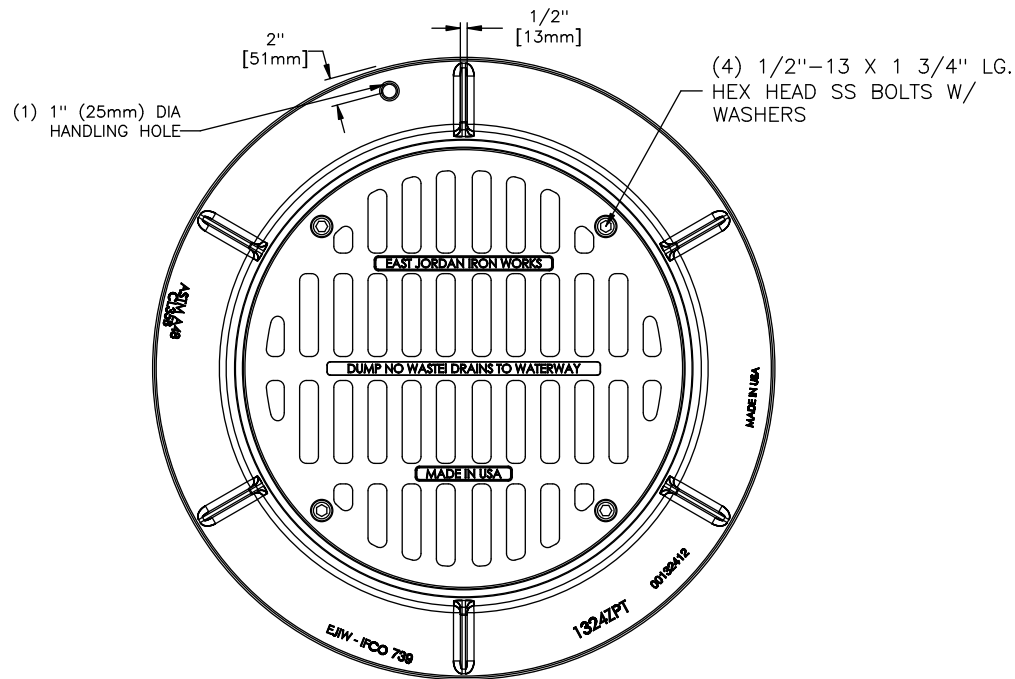

GRATE SECTION

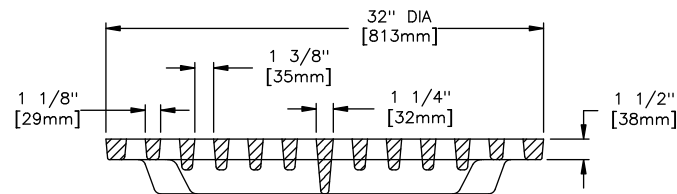

GRATE SECTION

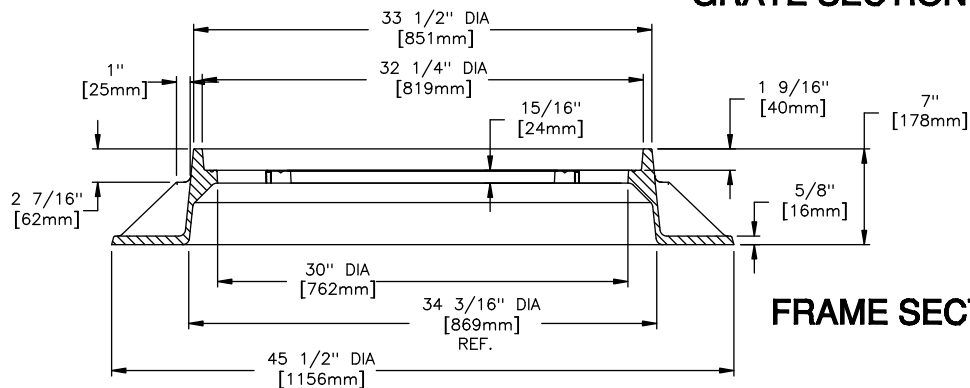

FRAME SECTION