

MACHINE SEAT DETAIL

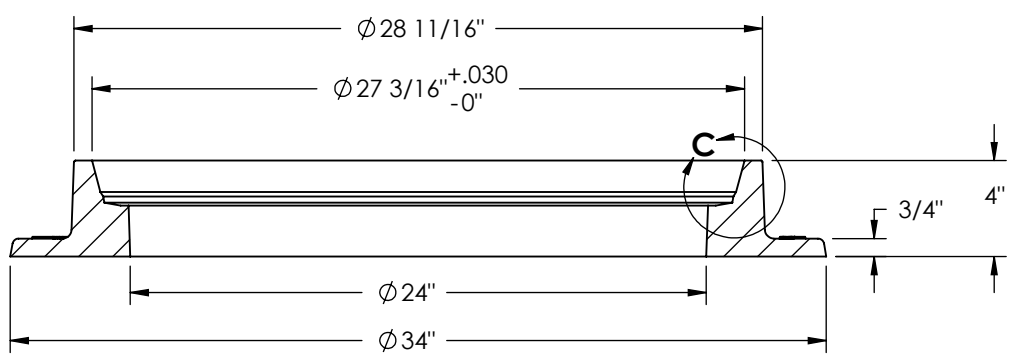

SECTION A-A

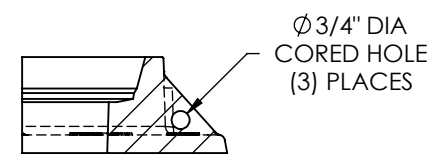

SECTION B-B

REF: LACSD #S-a-228

CONFIDENTIAL: This drawing is the property of East Jordan Iron Works, Inc. and embodies confidential information, trade secret information, and/or know how that is the property of East Jordan Iron Works, Inc. © Copyright 2008 East Jordan Iron Works, Inc.

| | |
|--|------------------|
| EJIW EAST JORDAN <small>IRON WORKS EST. 1883</small> 800-626-4653 www.ejiw.com MADE IN USA | |
| PRODUCT NUMBER 00311812 | |
| CATALOG NUMBER 3118Z1 | |
| FRAME (LB 1503) | |
| LOAD RATING HEAVY DUTY | |
| COATING DIPPED | |
| ESTIMATED WEIGHT FRAME: 206 LBS WEIGHT MAY VARY ±5% | |
| MATERIAL SPECIFICATION GRAY IRON ASTM A48 CL35B | |
| OPEN AREA N/A | |
| ✓ DESIGNATES MACHINED SURFACE | |
| DRAWN DEW | DATE 04/29/08 |
| LAST REVISED JIJ | DATE 04/23/09 |
| REFERENCE INFORMATION 00311812 | |