

REV.	APPR. BY	DATE

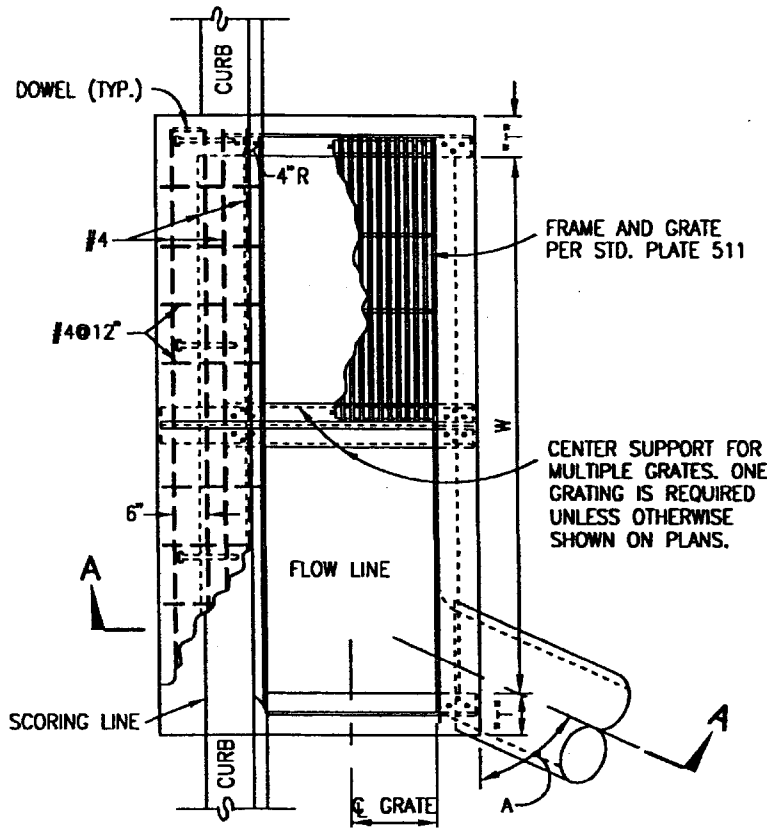

PLAN

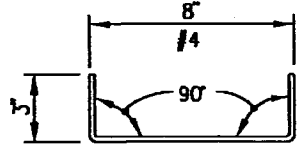

DOWEL DETAIL

REV.	APPR. BY	DATE

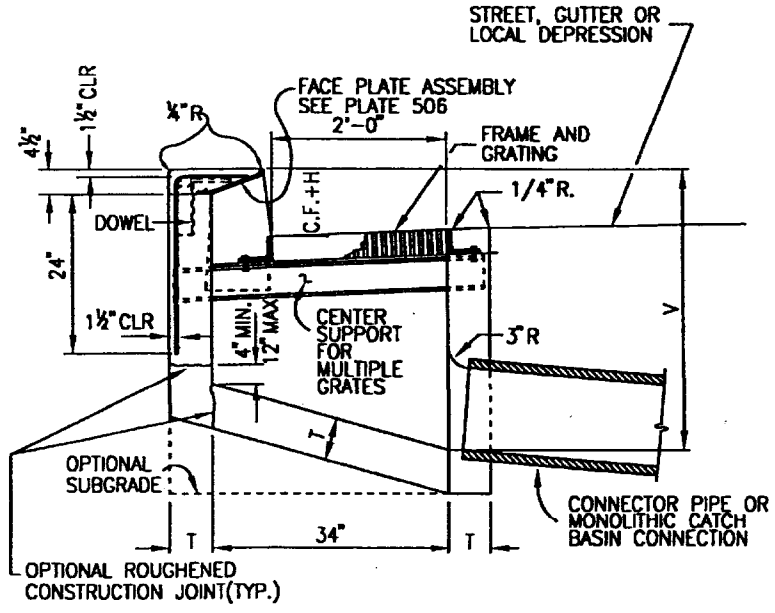

SECTION A-A

STRUCTURAL DATA			
WALL AND SLAB DIMENSIONS AND REINFORCEMENT REQUIREMENTS			
NO. OF GRATES	MAXIMUM V	T	REINFORCEMENT FOR WALLS AND SLABS
1-2	4'	6"	NOT REQUIRED
1-2	8'	8"	
1-2	10'	10"	
1-2	12'	10"	REQUIRED
3-4	4'	6"	NOT REQUIRED
3-4	7'	8"	
3-4	8'	8"	REQUIRED
3-4	12'	10"	NOT REQUIRED
5-6	4'	6"	
5-6	6'	8"	
5-6	8'	8"	REQUIRED
5-6	12'	10"	
>6	4'	6"	
>6	8'	8"	REQUIRED
>6	12'	10"	

	CITY OF OXNARD		CURB OPENING CATCH BASIN WITH GRATING(S)		STANDARD PLAN 2002
		DRAWN: STAFF	CKD.: STAFF		PLATE 502 SHEET 1 OF 2

NOTES:

1. WHERE THE BASIN IS TO BE CONSTRUCTED WITHIN THE LIMITS OF EXISTING OR PROPOSED SIDEWALK OR IS CONTIGUOUS TO SUCH SIDEWALK, THE TOP SLAB OF THE BASIN MAY BE POURED EITHER MONOLITHIC WITH THE SIDEWALK OR SEPARATELY, USING THE SAME CLASS OF CONCRETE AS THE BASIN. WHEN POURED MONOLITHICALLY, THE SIDEWALK SHALL BE PROVIDED WITH A WEAKENED PLANE OR A 1" DEEP SAWCUT CONTINUOUSLY AROUND THE EXTERNAL PERIMETER OF THE CATCH BASIN WALLS, INCLUDING ACROSS THE FULL WIDTH OF THE SIDEWALK. SURFACE OF ALL EXPOSED CONCRETE SHALL CONFORM IN SLOPE, GRADE, COLOR, FINISH, AND SCORING TO EXISTING OR PROPOSED CURB AND WALK ADJACENT TO THE BASIN.
2. ALL CURVED CONCRETE SURFACES SHALL BE FORMED BY CURVED FORMS, AND SHALL NOT BE SHAPED BY PLASTERING.
3. FLOOR OF BASIN SHALL BE GIVEN A STEEL TROWEL FINISH AND SHALL HAVE A LONGITUDINAL AND LATERAL SLOPE OF 1:12 MINIMUM AND 1:3 MAXIMUM, EXCEPT WHERE THE GUTTER GRADE EXCEEDS 8 PERCENT, IN WHICH CASE THE LONGITUDINAL SLOPE OF THE FLOOR SHALL BE THE SAME AS THE GUTTER GRADE. SLOPE FLOOR FROM ALL DIRECTIONS TO THE OUTLET.
4. DIMENSIONS:

V = THE DIFFERENCE IN ELEVATION BETWEEN THE TOP OF THE CURB AND THE INVERT OF THE CATCH BASIN AT THE OUTLET = 4.5'.

V_U = THE DIFFERENCE IN ELEVATION BETWEEN THE TOP OF THE CURB AND THE INVERT AT THE UPSTREAM END OF THE BASIN. V_U SHALL BE DETERMINED BY THE REQUIREMENTS OF NOTE 3, BUT SHALL NOT BE LESS THAN CURB FACE PLUS 12".

V_I = THE DIFFERENCE IN ELEVATION BETWEEN THE TOP OF THE CURB AND THE INVERT OF THE INLET, NOTED ON THE PROJECT PLANS.

H = 2" UNLESS NOTED ON THE PROJECT PLANS.

W = 2'-11 $\frac{3}{8}$ " FOR ONE GRATING: ADD 3'-5 $\frac{3}{8}$ " FOR EACH ADDITIONAL GRATING.

A = THE ANGLE, IN DEGREES, INTERCEPTED BY THE CENTERLINE OF THE CONNECTOR PIPE AND THE CATCH BASIN WALL TO WHICH THE CONNECTOR PIPE IS ATTACHED.

5. PLACE CONNECTOR PIPES AS INDICATED ON THE PROJECT PLANS. UNLESS OTHERWISE SPECIFIED, THE CONNECTOR PIPE SHALL BE LOCATED AT THE DOWNSTREAM END OF THE BASIN. WHERE THE CONNECTOR PIPE IS SHOWN AT A CORNER, THE CENTERLINE OF THE PIPE SHALL INTERSECT THE INSIDE CORNER OF THE BASIN. THE PIPE MAY BE CUT AND TRIMMED AT A SKEW NECESSARY TO INSURE MINIMUM 3" PIPE EMBEDMENT, ALL AROUND, WITHIN THE CATCH BASIN WALL, AND 3" RADIUS OF ROUNDING OF STRUCTURE CONCRETE, ALL AROUND, ADJACENT TO PIPE ENDS. A MONOLITHIC CATCH BASIN CONNECTION SHALL BE USED TO JOIN THE CONNECTOR PIPE TO THE CATCH BASIN WHENEVER ANGLE "A" IS LESS THAN 70 DEGREES OR GREATER THAN 110 DEGREES, OR WHENEVER THE CONNECTOR PIPE IS LOCATED IN A CORNER. THE OPTIONAL USE OF A MONOLITHIC CATCH BASIN CONNECTION IN ANY CASE IS PERMITTED. MONOLITHIC CATCH BASIN CONNECTIONS MAY BE CONSTRUCTED TO AVOID CUTTING STANDARD LENGTHS OF PIPE.
6. DOWELS ARE REQUIRED AT EACH CORNER AND AT 7' ON CENTER (MAX.) ALONG THE BACKWALL.
7. ALL CATCH BASINS SHALL INCLUDE INSTALLATION OF A PLACARD STATING "DON'T DUMP - DRAINS TO OCEAN". PLACARD SHALL BE PLACED ON THE LEFT SIDE OF BASIN OPENING. PLACARDS ARE AVAILABLE FROM STORMWATER QUALITY PROGRAM.
8. THE FOLLOWING STANDARD PLANS ARE INCORPORATED HEREIN:
 - 508 MONOLITHIC CATCH BASIN CONNECTION
 - 507 CATCH BASIN REINFORCEMENT
 - 506 CATCH BASIN FACE PLATE ASSEMBLY AND PROTECTION BAR
 - 511 FRAME AND GRATING FOR CATCH BASINS

REV.	APPR. BY	DATE

REV.	APPR. BY	DATE

 <p>CITY OF Oxnard</p>	CURB OPENING CATCH BASIN WITH GRATING(S)		STANDARD PLAN 2002
	DRAWN: STAFF	CKD.: STAFF <i>LB</i>	APPR. <i>Granville R. Bowman</i>
Department of Public Works			SHEET 2 OF 2