

STATE OF CALIFORNIA - DEPARTMENT OF TRANSPORTATION  
**Caltrans** HYDRAULICS  
 PROJECT ENGINEER WING-YAN LEE  
 CHECKED BY  
 DATE REVISIONS BY  
 DATE REVISIONS BY

TOP			
B	T	BOTH WAYS	
0.97 m TO 1.22 m	115 mm	#10 @ 150 mm	
1.22 m TO 1.83 m	125 mm	#10 @ 125 mm	

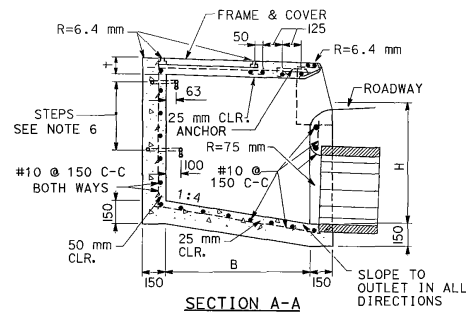
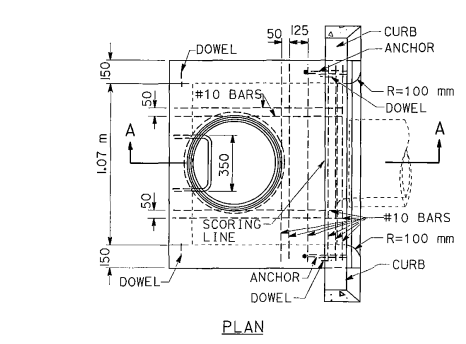

**NOTES**

- "h" IS THE DIFFERENCE IN ELEVATION BETWEEN THE OUTLET PIPE FLOW LINE AND THE NORMAL GUTTER GRADE LINE UNDEPRESSED.
- CONCRETE: WHERE THE BASIN IS TO BE CONSTRUCTED WITHIN THE LIMITS OF OR CONTIGUOUS TO A PROPOSED SIDEWALK, THE TOP SLAB OF THE BASIN SHALL BE POURED MONOLITHIC WITH THE SIDEWALK USING THE SAME CLASS OF CONCRETE AS IN THE STRUCTURE.
- CONNECTION PIPES MAY BE PLACED IN ANY POSITION AROUND THE WALLS PROVIDED THEY ALIGN IN THE PROPER DIRECTION AND THEIR POSITIONS ARE OTHERWISE CONSISTENT WITH THE DRAINAGE PLANS. WHERE MONOLITHIC CONNECTIONS ARE NOT USED, PIPES SHALL BE TRIMMED AT SKENS NECESSARY TO INSURE MINIMUM 75 mm PIPE EMBEDMENT AND ALLOW 75 mm RADIUS ROUNDING OF STRUCTURE CONCRETE ADJACENT TO PIPE ENDS. FOR DETAILS OF MONOLITHIC CONNECTIONS SEE DRAINAGE DETAIL.
- SURFACE OF ALL EXPOSED CONCRETE SHALL CONFORM IN SLOPE, GRADE, COLOR, FINISH, AND SCORING TO EXISTING OR PROPOSED SIDEWALK ADJACENT TO THE BASIN.
- FLOOR OF BASIN SHALL BE GIVEN STEEL-TROWELED FINISH AND SHALL SLOPE FROM ALL DIRECTIONS TO THE OUTLET. FOR INLETS TYPE C39 AND C40- THE DEPTH AT THE UPSTREAM END SHALL BE CURB FACE PLUS 460 mm UNLESS OTHERWISE SPECIFIED FOR "w" GREATER THAN 3.05 m.
- STEPS SHALL BE 19 mm ROUND, GALVANIZED STEEL. NONE REQUIRED WHERE "h" IS 1.07 m OR LESS. INSTALL ONE STEP 400 mm ± ABOVE FLOOR WHEN "h" IS MORE THAN 1.07 m AND LESS THAN 1.5 m. WHERE "h" IS MORE THAN 1.5 m, STEPS SHALL BE EVENLY SPACED AT 300 mm ± INTERVALS FROM 400 mm ± ABOVE FLOOR TO WITHIN 300 mm ± OF THE TOP OF BOX.
- DIMENSIONS:
  - INLET TYPE C38 - h = 0.91 m UNLESS OTHERWISE SPECIFIED.
  - INLETS TYPE C39 & C40 - h = 1.07 m UNLESS OTHERWISE SPECIFIED.
  - INLET TYPE C40 - w = 4.27 m UNLESS OTHERWISE SPECIFIED.
  - B = 0.97 m UNLESS OTHERWISE SPECIFIED.
  - T = 150 mm FOR SIDE WALLS AND BACK WALLS AND 200 mm FOR FRONT
  - IF "h" IS 1.07 m OR LESS.
  - T = 200 mm IF "h" IS GREATER THAN 1.07 m AND LESS THAN 2.44 m.
  - T = 250 mm IF "h" IS 2.44 m OR MORE.
  - CURB FACE = 230 mm UNLESS OTHERWISE SPECIFIED.
- CURVATURE OF THE SIDE WALLS AT CURB OPENING SHALL BE FORMED BY CURVED FORMS AND SHALL NOT BE MADE BY PLASTERING.
- MANHOLE SHALL BE PLACED ALONG BACK WALL NEAR OUTLET.
- FOR FRAME AND COVER DETAIL, SEE STD. PLANS B7-11, DETAIL U46.

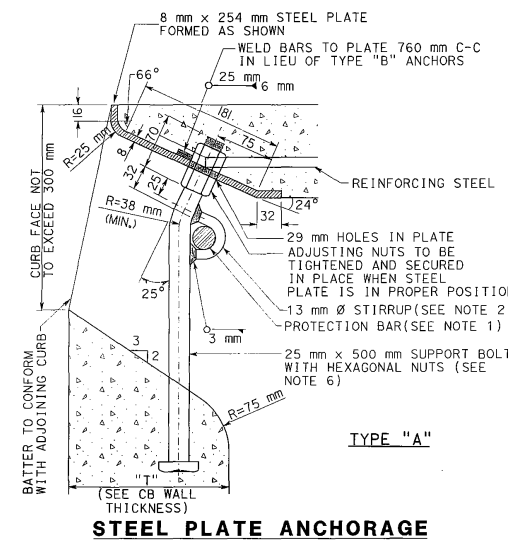

**STEEL PLATE ANCHORAGE**

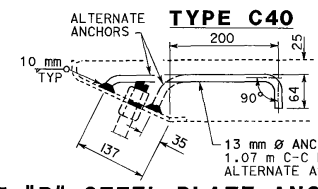

**TYPE "B" STEEL PLATE ANCHORAGE**

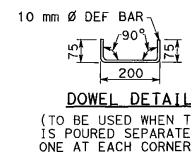

**TYPE C38**

DIST	COUNTY	ROUTE	KILOMETER TOTAL PROJECT	POST SHEET NO.	TOTAL SHEETS
07	LA	5,10,60,90,101,102,134,170,205,605	Var	332	1697

REGISTERED CIVIL ENGINEER  
 WING-YAN LEE  
 No. 61452  
 Exp. 6-30-05  
 CIVIL  
 STATE OF CALIFORNIA

PLANS APPROVAL DATE: 2-2-04

5-15-03

Caltrans now has a web site! To go to the web site, go to: <http://tracsd.caltrans.ca.gov>

**STEEL PLATE ANCHORAGE NOTES:**

- WHEN CURB FACE EXCEEDS 180 mm A PLAIN ROUND STEEL PROTECTION BAR 25 mm IN DIAMETER SHALL BE INSTALLED. BAR SHALL BE EMBEDDED 125 mm AT EACH END. WHEN LENGTH OF OPENING IS 2.1 m OR LESS, SAID BAR SHALL BE LOCATED 125 mm BEHIND CURB FACE AND 100 mm ABOVE GUTTER FLOW LINE.
- A STIRRUP SHALL BE WELDED TO EACH BOLT WHEN BOTH A PROTECTION BAR AND SUPPORT BOLT ARE REQUIRED.
- ALL EXPOSED METAL PARTS SHALL BE GALVANIZED.
- WHEN REQUIRED BY LENGTH OF OPENING BULB ANGLE MAY BE DELIVERED IN SECTIONS AND BUTT WELDED IN PLACE. ALL GALVANIZING DAMAGED BY WELDING SHALL RECEIVE TWO COATS OF ALUMINUM PAINT.
- TYPE A OR TYPE B ANCHORAGE MAY BE USED.
- SUPPORT BOLTS SHALL BE INSTALLED WHEN LENGTH OF OPENING EXCEEDS 2.1 m. SPACING SHALL BE 2.1 m C-C MAX AND 1.5 m C-C MIN.
- THE STEEL PLATE SHALL BE FABRICATED FROM 7.9 mm x 250 mm UNIVERSAL MILL PLATES.

ALL DIMENSIONS ARE IN MILLIMETERS UNLESS SHOWN OTHERWISE  
**DRAINAGE DETAILS**  
 NO SCALE

DATE PLOTTED: 13-SEP-2004  
 TIME PLOTTED: 08:18  
 00-00-00