

DIST	COUNTY	ROUTE	POST MILES TOTAL PROJECT	SHEET NO.	TOTAL SHEETS

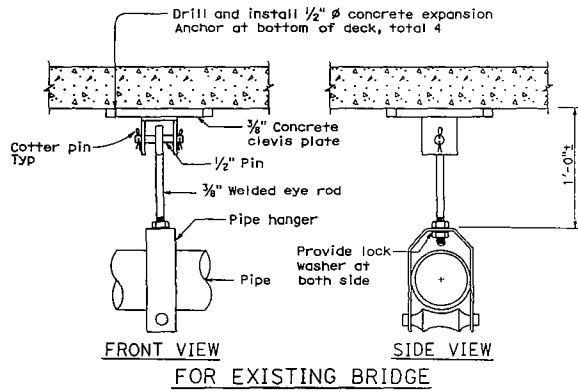

REGISTERED MECHANICAL ENGINEER May 1, 2006 PLANS APPROVAL DATE <small>The State of California or the officers or agents shall not be responsible for the accuracy or completeness of electronic copies of this plan sheet.</small> To get to the Caltrans web site, go to <a href="http://www.dot.ca.gov">http://www.dot.ca.gov</a>	
---	--



FRONT VIEW  
SIDE VIEW  
FOR EXISTING BRIDGE

PIPE HANGER

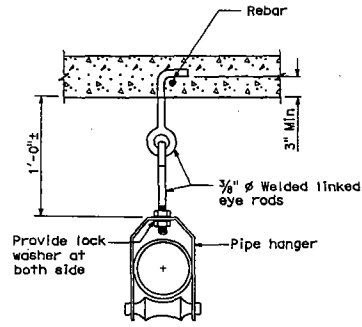

FOR NEW BRIDGE

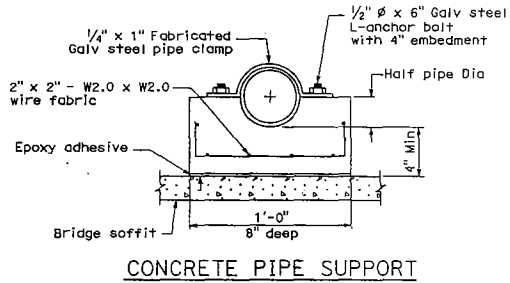

CONCRETE PIPE SUPPORT

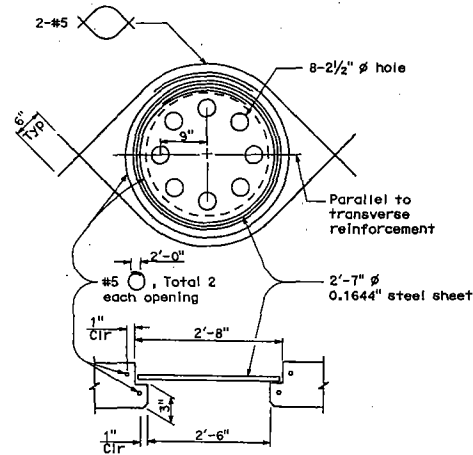

Locate where called for on bridge plans. Adjust reinforcement to clear opening. Plate must be installed before top deck is placed.

SOFFIT ACCESS OPENING

STATE OF CALIFORNIA  
DEPARTMENT OF TRANSPORTATION  
**WATER SUPPLY LINE (DETAILS)**  
**(PIPE SIZES LESS THAN 4")**

NO SCALE

B14-5

2006 STANDARD PLAN B14-5