

# 1812Z2PT/2812APT EXHD DI ASSEMBLY

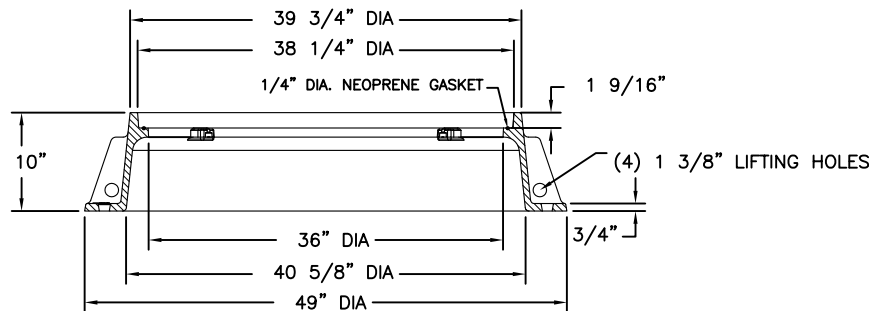
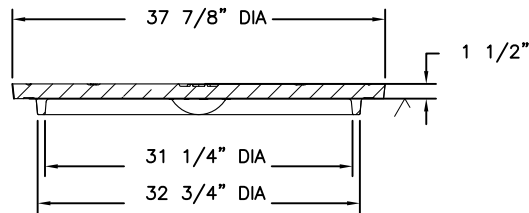
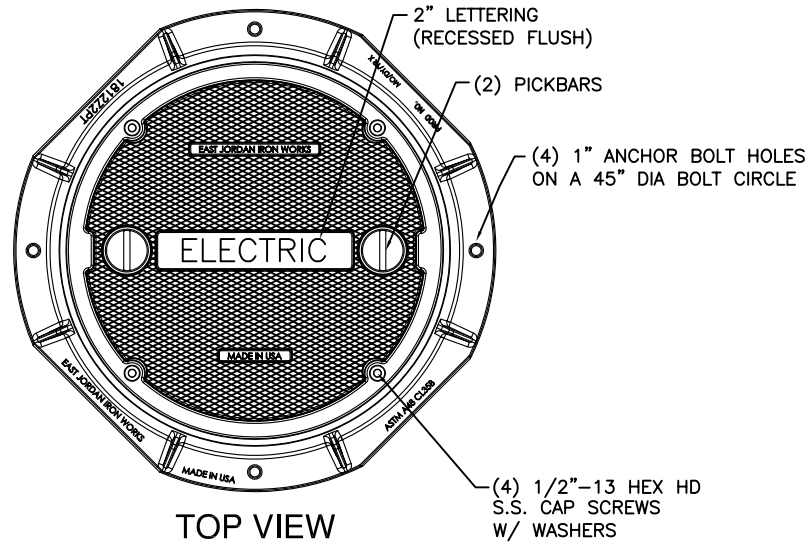

## PRODUCT NUMBER

00181208

## DESIGN FEATURES

### MATERIALS

COVER-DUCTILE IRON  
ASTM A536

FRAME-GRAY IRON  
ASTM A48 CL35B

### DESIGN LOAD

EXTRA HEAVY DUTY

### COATING

UNDIPPED

### OPEN AREA

N/A

√ DESIGNATES MACHINED SURFACE

## REFERENCE INFORMATION

00281351

00181212

## DRAWING DETAILS

ORIGINAL DRAWING: KH 12/04/08

REVISED BY: JJD 07/28/10

Corporate  
Headquarters  
301 Spring Street  
PO Box 439  
East Jordan, MI  
49727-0439  
800.874.4100



Call Today for  
More Information

800.626.4653

**EJIW EAST JORDAN**  
IRON WORKS EST. 1883  
WE COVER YOUR INFRASTRUCTURE

www.ejiw.com  
MADE IN THE USA

- Weights (lbs./kg.) dimensions (inches/mm.), and drawings provided for your guidance.
- We reserve the right to modify specifications without prior notice.
- Uncontrolled distribution.

CONFIDENTIAL: This drawing is the property of East Jordan Iron works, Inc., and embodies confidential information, registered marks, trade secret information, and/or know how that is the property of East Jordan Iron Works, Inc. ©Copyright 2009 East Jordan Iron Works, Inc.