

COVER BOTTOM

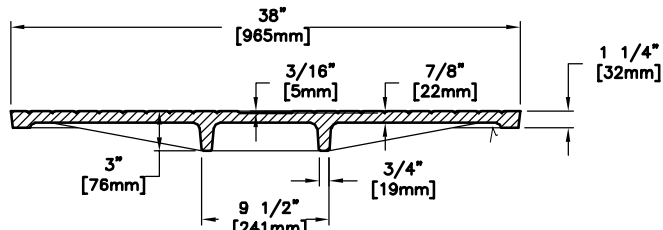

COVER SECTION

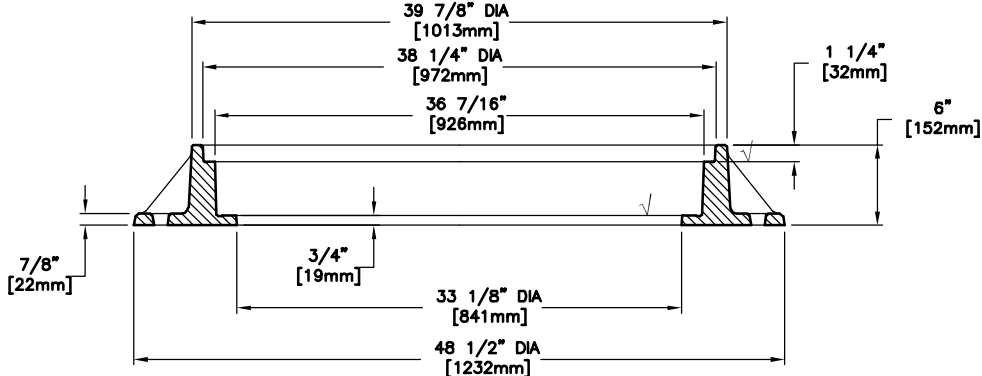

SECTION VIEW

✓ MACHINED SURFACE

EAST JORDAN
IRON WORKS, INC.
P.O. BOX 439
EAST JORDAN, MI. 49727
1-800-874-4100
FAX 231-536-4458

DRAWN SBB	DATE 11/05/03
--------------	------------------

APPROVED	DATE
----------	------

MANHOLE ASSEMBLY (LBIW X166)

PRODUCT NO.

00316601

CATALOG NO.

3166C
3166Z

REF. PRODUCT NUMBERS

316622
316610

EST. WT.

COVER: 291 LBS 132kg
FRAME: 510 LBS 232kg
FRAME: 801 LBS 364kg

OPEN AREA

N/A

MAT'L SPEC.

COVER - GRAY IRON
ASTM A48 CL35
FRAME - GRAY IRON
ASTM A48 CL35

LOAD RATING

HEAVY DUTY