

8195 Assembly

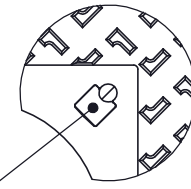
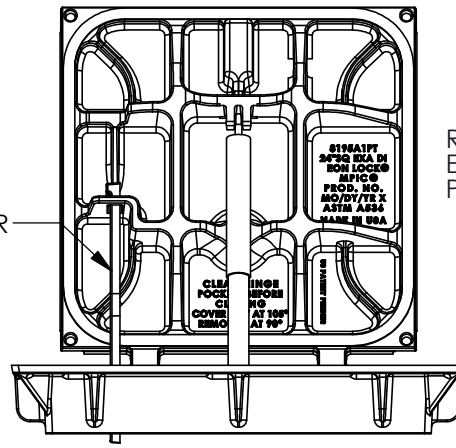
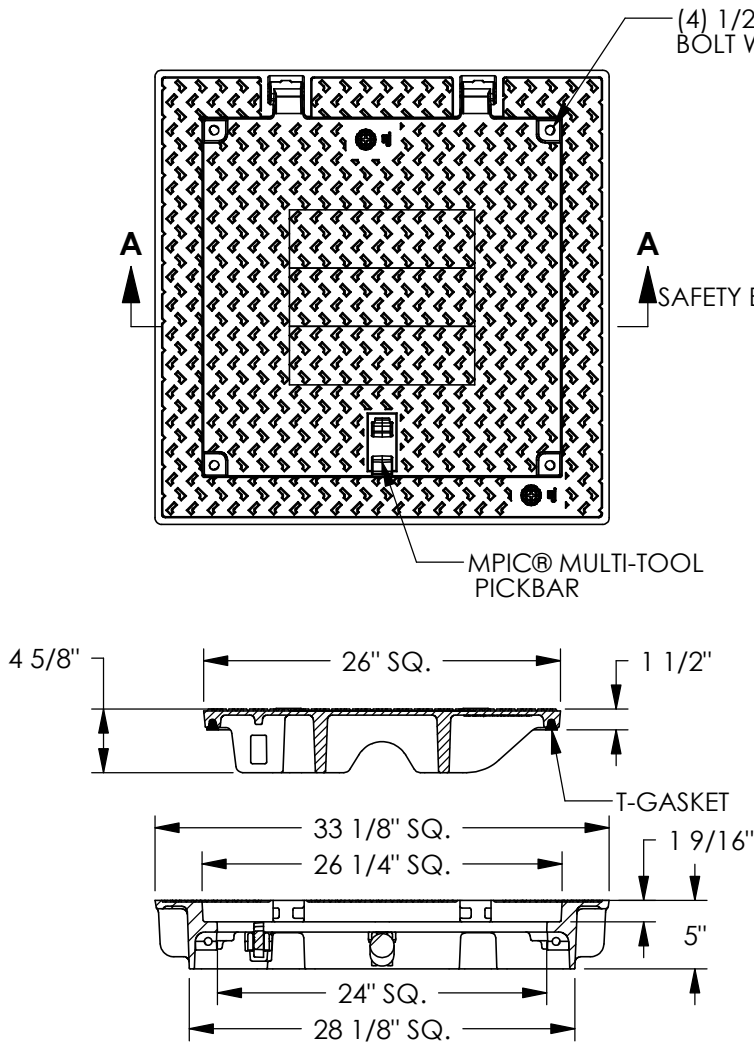

Product Number

00819581B01

Design Features

- Materials
 - Hatch Cover
Ductile Iron (70-50-05)
 - Hatch Frame
Ductile Iron (70-50-05)

- Design Load
Airport Extra Heavy Duty
(Proof Load Tested to 200,000lbs.)

- Open Area
n/a

- Coating
Undipped

- √ Designates Machined Surface

- Slip Resistant Surface with the LLLL® registered trademark

Certification

-ASTM A536

-Country of Origin: USA

Major Components

00819581

00819511

Drawing Revision

6/15/2010 Designer: DEF

2/8/2012 Revised By: SDC

Disclaimer

Weights (lbs/kg), dimensions (inches/mm) and drawings provided for your guidance. We reserve the right to modify specifications without prior notice.

CONFIDENTIAL: This drawing is the property of EJ Group, Inc. and embodies confidential information, registered marks, patents, trade secret information, and/or know-how that is the property of EJ Group, Inc. Copyright © 2011 EJ Group, Inc. All rights reserved.

Contact

800.626.4653

ejco.com

REMOVE COVER AT 90°
(AFTER REMOVING
MECHANICAL STRUT
AND SAFETY BAR)