

# 1905APT DI 1046ZPT ASSY

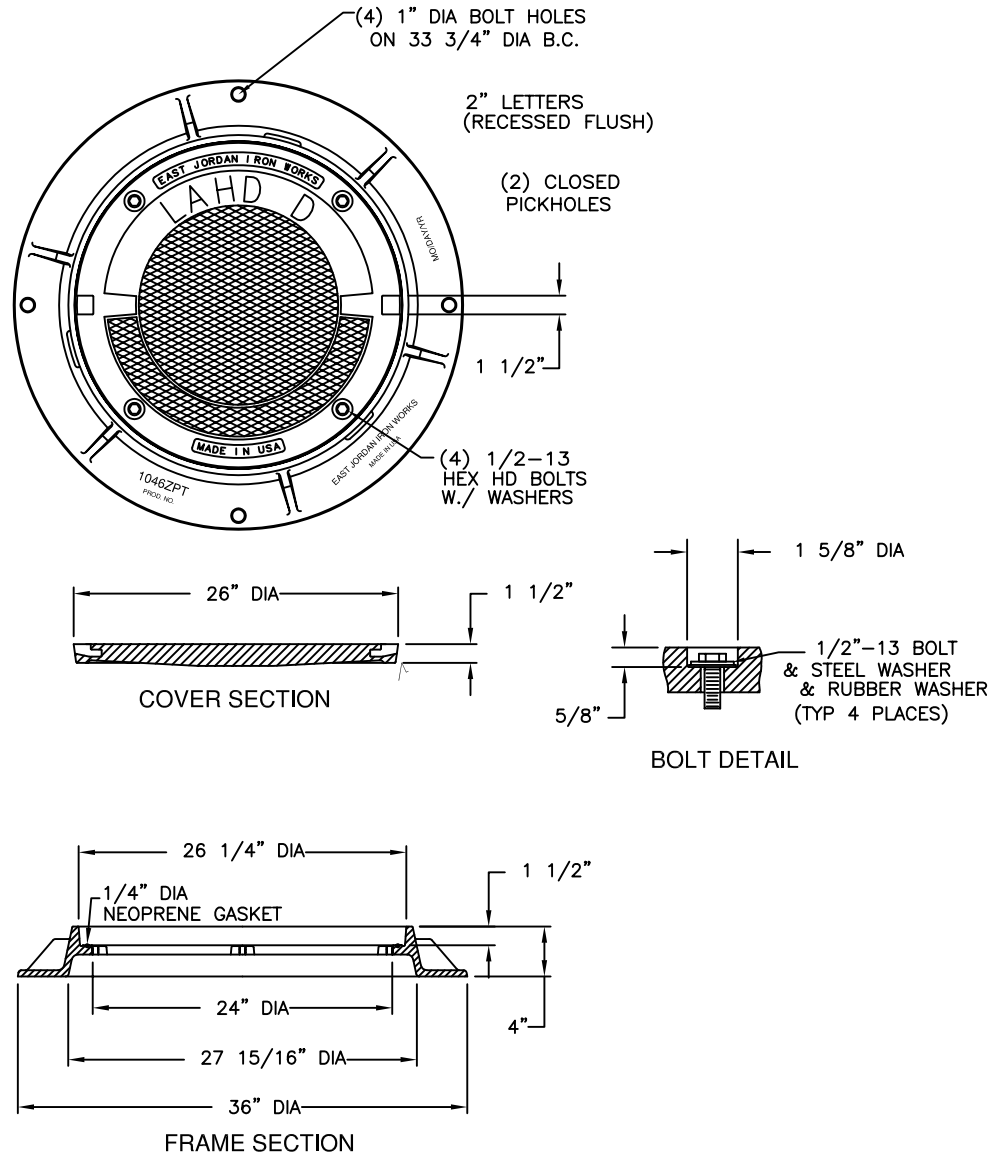

## PRODUCT NUMBER

00104653

## DESIGN FEATURES

### MATERIALS

COVER - DUCTILE IRON  
ASTM A536

FRAME-GRAY IRON  
ASTM A48 CL35B

### DESIGN LOAD

EXTRA HEAVY DUTY  
(PROOF LOAD TESTED  
TO 200,000 LBS.)

### COATING

DIPPED

### OPEN AREA

N/A

√ DESIGNATES MACHINE SURFACE

## REFERENCE INFORMATION

00190527  
00104612

## DRAWING DETAILS

ORIGINAL DRAWING: DEW 07/30/2001

REVISED BY: DEW 02/03/2010

Corporate  
Headquarters  
301 Spring Street  
PO Box 439  
East Jordan, MI  
49727-0439  
800.874.4100



Call Today for  
More Information

800.626.4653

**EJIW EAST JORDAN**  
IRON WORKS EST. 1883  
WE COVER YOUR INFRASTRUCTURE

www.ejiw.com  
MADE IN THE USA

- Weights (lbs./kg.), dimensions (inches/mm.), and drawings provided for your guidance.
- We reserve the right to modify specifications without prior notice.
- Uncontrolled distribution.

CONFIDENTIAL: This drawing is the property of East Jordan Iron works, Inc., and embodies confidential information, registered marks, trade secret information, and/or know how that is the property of East Jordan Iron Works, Inc. ©Copyright 2009 East Jordan Iron Works, Inc.