

1564ZPT 1564APT Assembly

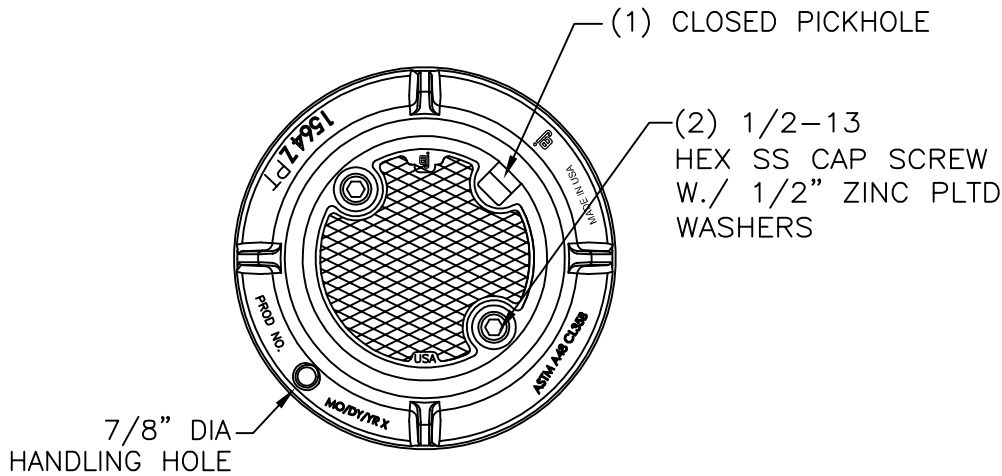

PLAN VIEW

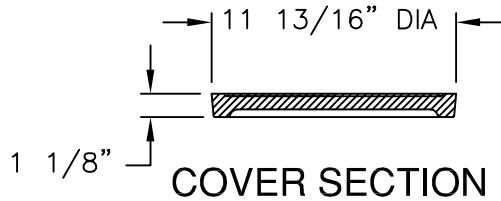

COVER SECTION

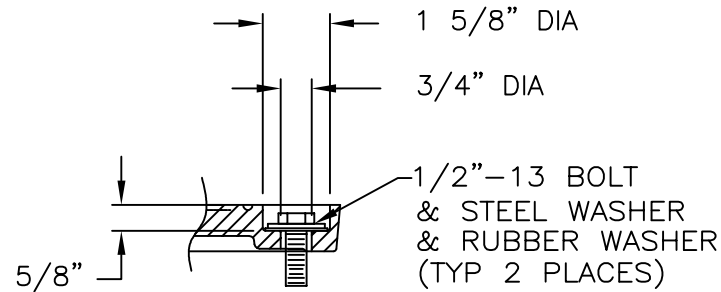

BOLTHOLE DETAIL

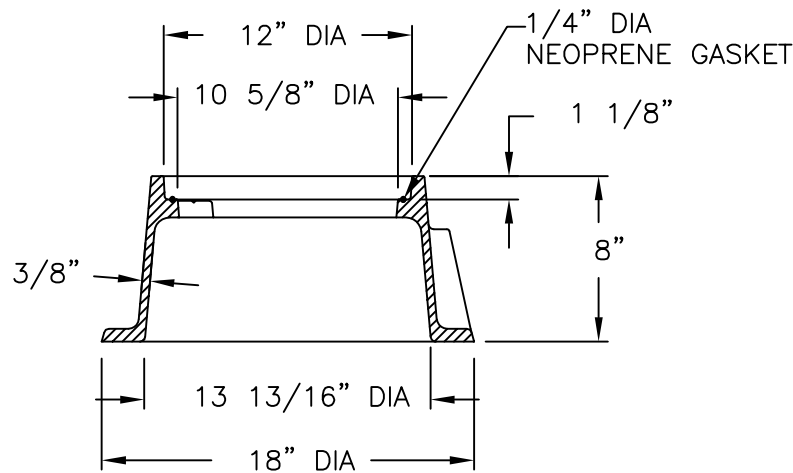

FRAME SECTION

NOTES

HEAVY DUTY
 GRAY IRON ASTM A48, CLASS 35B
 MEETS FAA 250 PSI TIRE PRESSURE REQUIREMENT

Product Number

00156425A01

Design Features

- Materials
 - Cleanout/Monument Box Frame
 Gray Iron (CL35B)
 - Cleanout/Monument Box Cover
 Gray Iron (CL35B)

- Design Load
 - Extra Heavy Duty
- Open Area
 - n/a
- Coating
 - Undipped
- √ Designates Machined Surface

Certification

- ASTM A48
- Country of Origin: USA

Major Components

00156413
 00156425

Drawing Revision

2/20/2009 Designer: GAD
 2/9/2021 Revised By: DAE

Disclaimer

Weights (lbs./kg) dimensions (inches/mm) and drawings provided for your guidance. We reserve the right to modify specifications without prior notice.

CONFIDENTIAL: This drawing is the property of EJ GROUP, Inc., and embodies confidential information, registered marks, patents, trade secret information, and/or know how that is the property of EJ GROUP, Inc. Copyright © 2012 EJ GROUP, Inc. All rights reserved.

Contact

800 626 4653
 ejco.com